

MR-Family

Servo Amplifiers and Motors

**Advanced Servo Technology
for ultimate positioning control**



**Industry Leading Performance / Reliable / High-Speed /
User-Friendly / SSCNETIII/H Capable / Flexible /**

Use tomorrow's technology today



High-speed high-precision control that adapts itself to mechanical characteristics

Maximized to the best advantage for the machinery

Mitsubishi Electric servo systems are globally renowned and respected. Offering a perfect combination of high-end performance and ease of use, they are now found in a huge range of applications throughout all branches of industry – from single and multiple axis systems in mechanical engineering and other metal-working sectors to complex, fully-synchronised solutions in the semiconductor and motor industries.

Meeting global norms and standards

Mitsubishi Electric's servo amplifiers and motors meet all the standards and specifications laid down in the EU Low Voltage Directive 73/23/EEC and the Machinery Directive 98/37/EC. Needless to say, all systems carry the CE mark and are certified as conforming to UL, cUL and GOST.

Manufactured at the highest standards

Mitsubishi Electric automation products enjoy a global reputation for outstanding quality and reliability. The process starts at the design stage, where quality is designed into even the smallest components. Our systematic pursuit of "best practice" means that Mitsubishi Electric products readily comply with product directives and global standards.

Contents

What makes a good servo system	4-5	
Servo system overview	6	
Servo amplifiers	7	
The convincing reasons	8-9	
Safety first	10	
The best motors	11	
Plug and play positioning solutions	12	
Motion Controller	13	
Software	14	
Applications	15-16	

What makes a good servo system



Cost effectiveness

Industry leading performance gives faster production cycles and reduced material wastage.



Plug and play

The availability of pre-made cables of different length means that connecting a servo motor to an amplifier or any other combination is quick and error free.



Simple networking

High-speed servo and motion applications need special high-speed networking. Mitsubishi Electric's Servo System Controller Network (SSCNET III/H) provides these system capabilities.

The built-in display panel indicates servo amplifier status and alarm numbers.

Advanced and evolving tuning functions like „One-Touch-Tuning“

Automatic servo motor recognition

Absolute high-resolution encoder as standard equipment



High speed, high performance
Motion Bus system SSCNETIII/H



STO I/O signal
connector CN8

Triple-axes amplifier

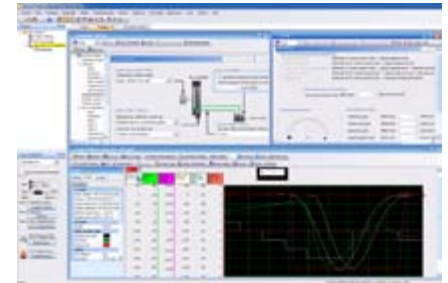

Simple setup and tuning

In combination with the „One-Touch-Tuning“ of the MR-J4 and the software MRConfigurator2, the amplifier tunes itself for an easy and fast startup of the machine.



Functionality

The MR-J4 series has incorporated advanced control capabilities, that are able to maximize the best advantage from the machinery.

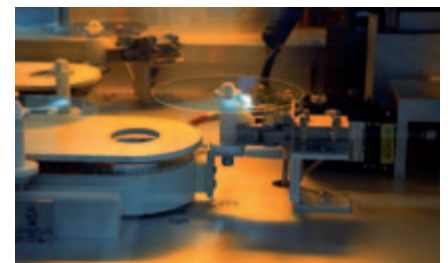

Compact & flexible

Mitsubishi Electric's servo systems are both compact and flexible. The reduced component size means more flexibility for installation and reduced enclosure sizes.

Extensive product range

The right solution every time

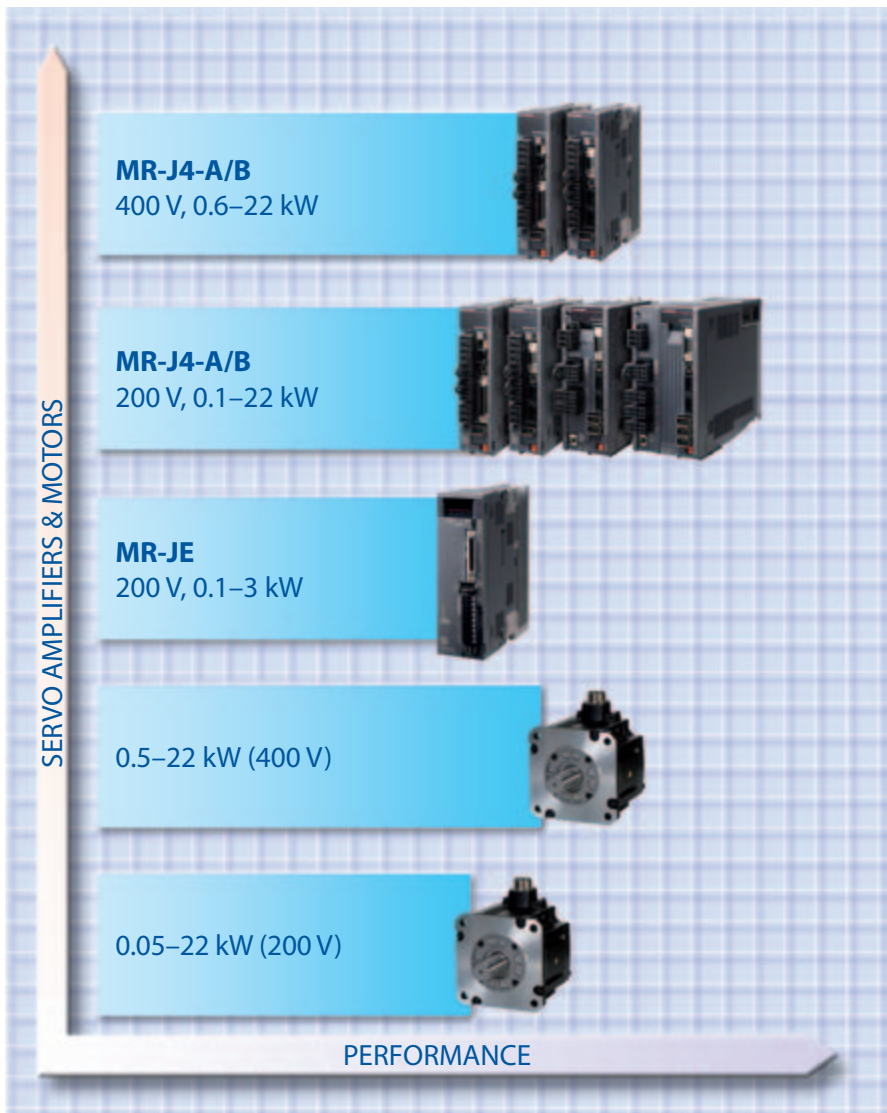

A diverse product range helps you make the right product choice.



"Plug & play" technology

A solution for every application

Mitsubishi Electric always has the right servo system for straightforward and complex applications alike. With so many motor types, different amplifier output performances and features, the right servo solution is available for every conceivable positioning requirement.

The MELSERVO MR-J4 series of servo amplifiers and the associated positioning units, motion modules and high-end motion control systems from Mitsubishi Electric enable machine builders and end customers to increase production safety and improve productivity. The MR-J4 amplifier range with its high performance potential and wide-ranging functionality scores in all areas thanks to simple operation and commissioning. The MR-J4 is of particular interest for manufacturers of packaging machines, traversing tables and handling systems.

The MR-JE series high performance servo amplifiers and servo motors combine proven reliability with a 2.0 kHz high-frequency response and an energy-saving design, they offer the best-in-class performance with the setup ease of advanced one-touch tuning. Fully compliant with global standards and ready for deployment worldwide, the MR-JE series is the right servo solution for all kinds of machines and applications.

The ever-evolving new generation servo

Powerful amplifiers

The MR-J4 generation of servo drives delivers state-of-the-art technology and simple operation in a very compact package. Functions like the advanced vibration suppression system and the further improved real-time auto-tuning ensure maximum precision, very short positioning times and simple installation.

Mitsubishi Electric offers a wide spectrum of servo amplifiers to meet the demands of all types of applications. The MR-J4-A models are suitable for drive systems with conventional control and are designed for regulating speed, torque and position control tasks. The MR-J4-B models are specified for complex, multi-axis movement sequences and for use in networked automation systems.

The units configure themselves by Plug & Play for Mitsubishi Electric's motion control and positioning control systems, to which they are connected via the high-speed optical SSCNETIII/H network, which has a cycle period of just 0.22 milliseconds.

The MR-J4 is currently available with outputs from 50 W to 22 kW. Units with higher outputs are being added to the range at regular intervals.

Built-in positioning function

A simple positioning system can be configured without a controller such as positioning module since the positioning function (point table and program methods, and indexer positioning operation) is built into the MR-J4-A-RJ servo amplifier.



Handling systems require exceptional precision and dynamic response.

MR-J4 Servos at a glance

Power range

MR-J4-A/B (200 V type):	0.1–22 kW
MR-J4-A/B (400 V type):	0.1–22 kW
MR-J4-W2-B:	0.2–1.0 kW
MR-J4-W3-B:	0.2–0.4 kW

Input

MR-J4-A/B, MR-J4W2-B, MR-J4W3-B:	200–230 V AC (50/60 Hz)
MR-JE-A4/B4:	380–480 V AC (50/60 Hz)

Speed frequency response

Up to 2500 Hz

Control functions with enhanced tuning technology

Real-time auto-tuning and
Model adaptive control;
Advanced vibration suppression

Integrated interfaces

RS422

Network links

MR-J4-B/MR-J4-W2-B/MR-J4-W3-B:	SSCNETIII/H
MR-J4B-RJ010 + MR-J3-T10:	CC-Link IE Field

Safety Solutions

According to EN IEC 61800-5-2
Safe Torque Off (STO)

Safety option card

MR-D30 for SS1, SLS, SSM, SBC



Plug and play minimises wiring errors and speeds up installation

The power to perform



Feed equipment is one of the servo's many applications.

The amplifiers also feature a "Life Diagnosis Function". This function checks the state and quality of the installed components, such as capacitors and relays, over the whole life cycle, and informs the user and operator of any abnormalities. This virtually eliminates failures and machine downtime.

Mechanical system characteristics are also monitored, and undesirable vibration and friction are checked and directly suppressed, thus preventing system resonance. This function not only damps drive train vibrations but also oscillations at the end of a tool arm.

The absolute encoder which is fitted as standard has a resolution of 22 bits. This corresponds to more than 4 million pulses/revolution. The result is excellent true-running characteristics and a maximum positioning accuracy and processing speed which more than satisfy the performance requirements of modern high-end machines.

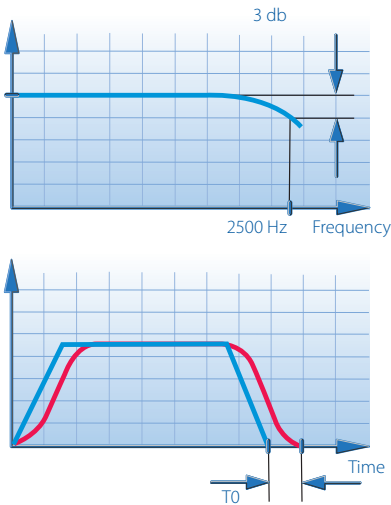

High speed response of 2500 Hz offers shortest settling times resulting in short cycle times.

Innovative and powerful

The MR-J4 amplifier series has been developed for the automation requirements of tomorrow. Mitsubishi Electric has incorporated numerous innovative and user-friendly functions to minimise the time-consuming and elaborate matching of mechanical and electronic systems.

The new one-touch tuning function minimises time consuming system adjustments between machine and electronics by touching one button. Control parameters are optimised and resonance frequencies of the machine and the mechanics are detected and filtered. An individual adjustment of single applications is not needed. The result is a vibration free, high precise and high speed positioning process – only by one click.

The system tunes itself quickly and easily thanks to "Real-time auto-tuning" and "Vibration suppression control". These functions are available both at start-up and during operation and thus reduce commissioning and parameterisation times.

Increased response speed

■ Three times faster communication speed

Communication speed is increased to 150 Mbps full duplex (equivalent to 300 Mbps half duplex), three times faster than the conventional speed. System response is dramatically improved.

■ Cycle times as fast as 0.22 ms

Smooth control of machine is possible using high-speed serial communication with cycle times of 0.22 ms.

Firmware that delivers performance

All MR-J4 servo amplifiers use the very latest regulation and control technologies. These systems ensure fast installation and setup and make it possible to configure stable systems with very short response times – no matter what’s your application.

■ Real-time auto-tuning

The real-time auto-tuning function sets the servo’s control parameters automatically, eliminating the need to calibrate the system for each individual application. But that’s not all – auto-tuning also works continuously while the system is in operation, making constant adjustments to cater for applications with fluctuating moments of inertia. This makes it possible to use these servos in a much wider range of applications.

Precise tuning functions

■ Advanced suppression of mechanical vibration

Advanced vibration suppress control is designed to suppress the vibrations in Category 2 and above. It is effective in suppressing residual vibrations at the time of settling during positioning operation.

The primary control method of the MR-J4 is model adaptive control. In this method, the motor is driven in such a manner that the tip of the given machinery moves together with the reference model applied.

Under advanced vibration suppress control, it uses a mechanical vibration model from reference model to generate a drive pattern that prevents the tip of machinery from vibrating, thereby suppressing any residual vibration. Advanced vibration suppress control can extract vibration components from actual motor movements. It identifies the vibration characteristics of the machinery in real time, and automatically makes adjustment to the mechanical vibration model.

■ Adaptive filtering

The optimum machine resonance suppression filter is automatically set to suppress resonance without even measuring the machine system’s (drive shaft) frequency characteristics. The adaptive frequency range has been increased compared to the prior models, so resonance at the drive shaft can also be suppressed.

When a given machine has a mechanical resonance at a high frequency (in the range of several hundred Hz and above), increased control gain will cause the control system to oscillate in this vibration mode and subsequently lose control. In order to overcome the mechanical resonance, it is common practice to insert a machine resonance suppression filter into the control loop to prevent oscillation. Adaptive filter II is a function that automatically sets this machine resonance suppression filter in real time.

SSCNETIII/H – The benchmark standard

■ High-speed motion

In addition to conventional pulse train positioning, the MR-J4 series also supports the SSCNETIII/H high-speed motion control network. The SSCNETIII/H is a high-speed synchronous network using an optical fiber cable. The MR-J4-B servo amplifier is connected to a control device with SSCNETIII/H interface (e.g LD77MS/QD77MS Simple Motion module, MR-MQ100/Q170MSCPU/Q172DSCPU/Q173DSCPU Motion Controller or FX3U-20SSC-H interface module). As for the communication specifications of SSCNETIII/H, it can control up to 32 axes per master interface.

Since long-distance wiring has become possible, it is possible to locate the controller’s control panel and drive units far apart and spread widely in a large-scale facility or a large-scale production line. This, in turn, will shorten the cable between amplifier and motor in machines where there is a relatively large amount of wiring.

■ No transmission collision

The fiber-optic cables thoroughly shut out noise that enters from the power cable or external devices. Noise tolerance is dramatically improved as compared to metal cables.

■ Powerful setting tools

As for the servo adjustments, a servo setting and support tool, Works2 can be used over SSCNETIII/H, just simply connect a personal computer to the motion controller makes it possible to perform controller settings and servo parameters of all the connected axes to SSCNETIII/H.

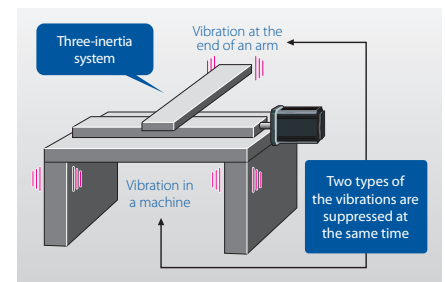

Automatic vibration suppression

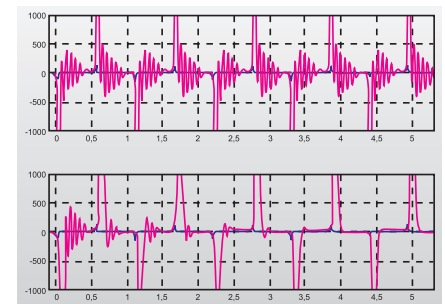

Adaptive filter (upper figure) to suppress drive shaft vibrations such as in a ball screw

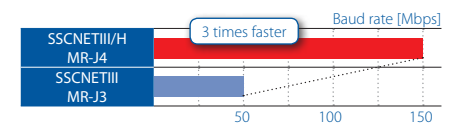

Network communication speed

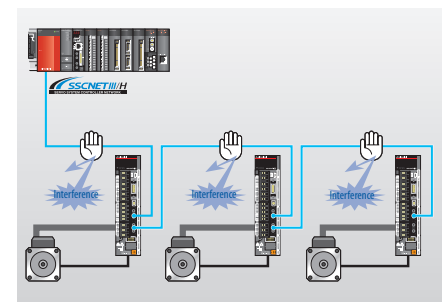

Reduction of interference by the SSCNETIII/H optical network

Safety first



Maintain machine performance while meeting required safety standards

The safe choice for motion

Mitsubishi Electric's MR family has become the leading choice for motion applications world wide. Industry leading performance, the SSCNETIII/H motion network, and patented technology like vibration suppression has lead to a significant global installed base. Mitsubishi Electric now takes this success one step further by adding safety functions to the MR-J4 line up.

Standards compliance

The MR-J4 motion safety solution is fully certified by third party accreditation organizations like TÜV. It complies with both EN 13849-1 for machine safety and ISO 61508 for functional safety. Hence specifying this solution in a motion system assists engineering staff to meet the requirements of mandatory certifications such as the EU Machinery Directive (2006/42/EC).

Comprehensive safety functions

Together, these devices offer a comprehensive motion safety solution. Implement safety functions using just the amplifier, or with both units, depending on system requirements. The MR-J4 amplifier by itself offers a Safe Torque Off (STO) function according EN 60204-1 that prevents an unexpected re-start. In conjunction with the MR-D30 safety unit, the MR-J4 series can be expanded by the addition of other EN 61800-5-2 safety function such as SS1, SBC, SSM and SLS. Hence system designers can select an economical solution that provides only the functions they need.

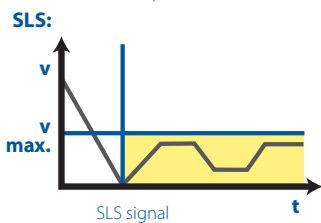
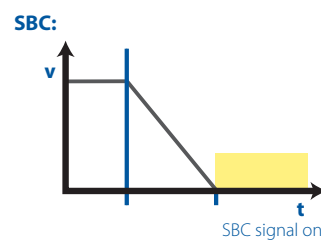
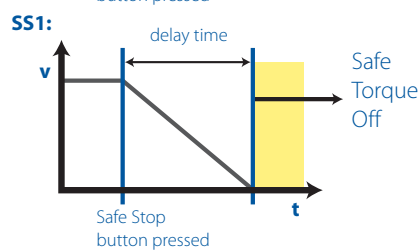
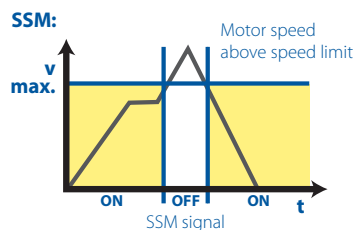
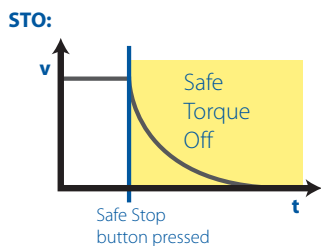

Maintain safe control of motor behaviour even in emergency situations

Servo motors to add movement

Motor solutions for all

Featuring the most advanced concentrated winding techniques and the latest technology, Mitsubishi Electric servo motors are among the most compact in the market.

MR-J4 series servo amplifier operates rotary servo motors, linear servo motors and direct motors as standard.

Motors are available in a range of options from 50 W to 22 kW in different designs, including specialised motors such as hollow shaft and direct drive motors that suit most application needs.

All Mitsubishi Electric servo motors provide integrated ABS encoders. Additional return-to-origin routines, limit switches or other sensors are not required.

Moreover, Mitsubishi Electric's low, ultra low and medium inertia designs allow users to select the best motor characteristics for their application.



Speed, accuracy and control, whenever you need it.

Advanced features

■ Increased motor speed

MR-J4 motors lead the market, combining speeds of up to 6,000 rpm with high torques. This makes it easier for designers to select the motors they need to meet tough performance criteria.

■ Increased encoder resolution

All MR-J4 encoders are 22 bit, delivering industry-leading 4,194,304 pulses per revolution. This high resolution makes it possible to detect and suppress mechanical vibrations. The non-volatile absolute encoder system has a backup battery, eliminating the need for time-wasting zero-point calibration routines.

■ Improved motor IP ratings

All MR-J4 motors are IP65 rated as standard (all 400 V motors are IP67). This means that MR-J4 systems can be used in heavy-duty industrial environments.



HG motor series – IP65/IP67 standard protection



Large choice of different servo motors

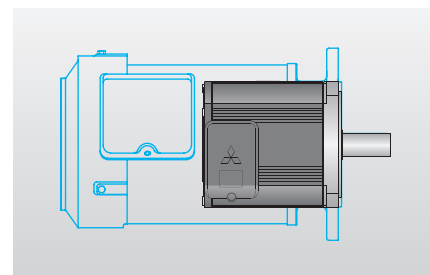

Size comparison to conventional motors

Plug & play positioning solutions



Fast, high-precision positioning



SSCNETIII/H configuration

Using the right positioning solution can help increase the accuracy of the work process, reduce waste and rework as well as provide a higher quality of production.

The MR-J4 series together with SSCNETIII/H support a very broad spectrum of applications with between 1 and 96 axes. Components with a variety of different PLC and positioning systems for a modular and fully-scalable configuration can be combined. This gives the user full control over the system and complete cost transparency, combined with the dependable controller performance of the MELSEC FX series or the MELSEC System Q and L series with motion controllers.

The range starts from simple pulse train positioning controllers over dedicated motion cards to most complex applications with MELSEC System Q motion CPUs.

Positioning modules

■ MELSEC FX positioning modules

High-speed counter and single axis positioning modules are available, which can be used in combination with the FX series PLCs. This provides a cost effective solution for small servo/motion applications. To archive a cost effective solution for high precision, the FX3U-20SSC-H module with SSCNETIII/H connection can be used.

■ MELSEC Simple Motion module

The MELSEC System Q and MELSEC L series lineup includes Simple Motion modules for various control functions previously only possible with Motion Controllers, such as torque control, synchronous control and cam control. These functions can be realized with simple parameter adjustments and via the PLC program.

Mark sensors allow use in packaging industry, filling plants, etc., without additional optional modules. A function for automatic calculation of cam data for applications with rotating cutters is implemented – only by setting the length of the product and the synchronisation path. With positioning functions, like linear interpolation (up to 4 axes), circular interpolation (2 axes) and path control it is easy to realize different applications, like X-Y tables, sealing, etc.

Motion Control and PLC in perfect harmony

Motion control systems have huge potential for optimising production processes and improving product quality. To control these systems, MELSEC System Q offers solutions ranging from individual motion/positioning cards to advanced motion CPUs capable of synchronised operation across many axes.

MELSEC System Q's unique design allows users to select and use different combinations of CPUs from the same platform.

Thanks to the dedicated motion control network SSCNETIII/H, each motion CPU can connect up to 32 servo axes. In addition, three motion CPUs can be used in a single MELSEC System Q solution to bring advanced motion control to 96 axes.

A whole solution for Motion Control

Only use what you need

For most applications, a complete control platform of a PLC and motion controller will do the job. However, for smaller systems, this may not address competitive cost pressures. The MR-MQ100 allows a single axis to be completely controlled and synchronised to a separate encoder or virtual axis with no additional controller hardware. Hence applications such as rotary cutters, flying saws and labelling can be economically accomplished without exceeding a tight control budget.

Limit cost, not options

While the MR-MQ100 is an economical solution, this doesn't mean lacking in features. A complete range of essential functions are available, including encoder and virtual axis synchronization, registration, point to point positioning and user defined cam profiles. In addition, the hardware complements these powerful software features with built-in I/O and SSCNETIII motion networking capability as well as an Ethernet port.

Reduced wiring

The MR-MQ100 also helps keep system costs down with its use of SSCNETIII, Mitsubishi Electric's simple but rugged optical fiber motion network. A single fiber connection is all that's needed to provide full communication and control over all functions of the MR-J4B servo amplifier regardless of capacity. A standard Ethernet connection is also provided to link the MR-MQ100 to the MT Works2 software.

Fully integrated

The Q170MCPUCPU offers the ability to provide a complete automation solution with a single, compact device. Its main strength is the ability to control up to 16 axes over a single SSCNETIII/H connection. However, rather than just being a simple motion controller, a comprehensive PLC capability is also built in. Hence the Q170MCPUCPU offers the ability to address a range of applications such as more sophisticated packaging machinery, labeling and material handling applications.



Apply the MR-MQ100 in a wide variety of motion applications

Flexibility

Most motion systems offer sophisticated axis control functions. However, the Q170MCPUCPU also opens up a huge range of PLC application possibilities by being compatible with over 100 of the MELSEC System Q I/O modules. This means application challenges such as analogue I/O, high density digital I/O, networking and others can easily be tackled by the Q170MSPCU. For companies already using MELSEC System Q, spare parts will be common to their other systems, reducing cost and administration tasks.



Choose from over 100 MELSEC System Q I/O modules

Fast, easy system set-up

High performance is less valuable if it's hard to use. The MR-MQ100 and Q170MCPUCPU avoids this with the intuitive MT Works2 software that replaces abstract programming with graphical models of the actual mechanical system. It's easy to create virtual clutches, gears and cam profiles by simple drag and drop selection.



Program by creating virtual mechanical systems

Servo setting and support software

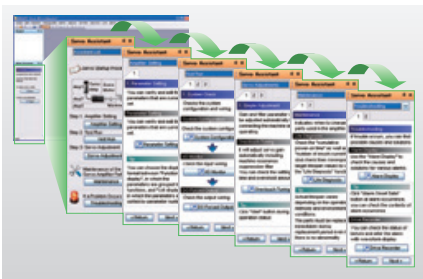

Just follow the the guidance and setup is complete

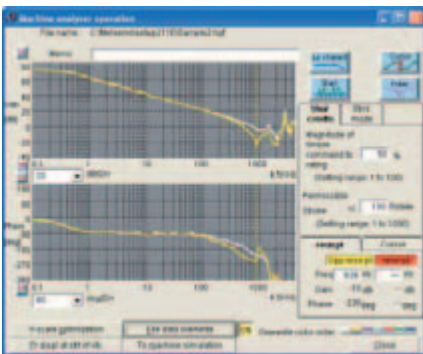

Monitoring and checking with the diagnostics features

MR Configurator2 – a complete engineering environment

The MR Configurator2 software package makes configuration and diagnostics quick and easy and includes powerful graphical machine analysis and simulation functions. Machine analysis enables determination of the frequency response of the connected drive train without any additional instruments. If necessary, you can then make design changes or install filters to achieve better machine performance. The system can be connected to a personal computer with a standard USB port.

A wide range of automatic configuration assistants make it easy to set up your new servo systems correctly, even for less experienced users. The strong benefits are:

Preparation

■ Easy set up

MR Configurator2 allows for easy set up and tuning the servo system with a standard personal computer.

■ Servo assistant function

Complete setting up the servo amplifier just by following guidance displays. Setting parameters and tuning are easy since related functions are called up from short-cut buttons.

Startup

■ Multiple monitor functions

Graphic display functions are provided to display the servo motor status with the input signal triggers, such as the command pulse, droop pulse and speed.

■ Parameter setting function

Display parameter setting in list or visual formats, and set parameters by selecting from the drop down list. Set in-position range in mechanical system unit (e.g. μm). Parameter read/write time is approximately one tenth of the conventional time.

Maintenance

■ Test operations with a personal computer

Test operation of the servo motors can be performed with a personal computer using multiple test mode menus.

■ Machine diagnosis function

This function estimates and displays machine friction and vibration in normal operation without any special measurement. Comparing the data of the first operation and after years of operation helps to find out the aging deterioration of machine and is beneficial for preventive maintenance.

Servo adjustment

■ One-touch tuning function

Adjustments including estimating load to motor inertia ratio, adjusting gain, and suppressing machine resonance are automatically performed for the maximum servo performance just by clicking the start button. Check the adjustment results of settling time and overshoot.

■ Graph function

The number of measurement channels is increased to 7 channels for analog, and 8 channels for digital. Display various servo statuses in the waveform at one measurement, supporting setting and adjustment. Convenient functions such as [Overwrite] for overwriting multiple data and [Graph history] for displaying graph history are available. Waveform measurement for the connected axes is simultaneously performed via controller communication.

■ Machine analyzer function

Input random torque to the servo motor automatically and analyze frequency characteristics (0.1 Hz to 4.5 kHz) of a machine system just by clicking the [Start] button. This function supports setting of machine resonance suppression filter, etc.

■ Improved usability

While automatically fluctuating the gain, the setup software MR Configurator searches for values with the shortest settling time and lowest overshooting or vibration.

Basic setting parameters can be easily set in a selection format. Settings in the list format are also possible.

Vertical form fill & seal

Sealing packaging solutions

Vertical form fill & seal applications utilize servo motor technology to accurately pull and feed plastic film material from a roll stock to be heat formed, volume dosed with a product, and then sealed and cut to be carried away by an unloading conveyor. While the methods for filling and sealing vary from machine to machine, vertical form fill & seal applications are essentially organized into two categories: Continuous motion bagging machines and intermittent motion bagging machines. Product entering the feeder can vary from a viscous fluid to a solid material and will often play a key role in how the machine is designed.

Which automation components are important

As part of the Simple Motion Module programming environment, virtual servo motor movement can be commanded through an electronic line shaft in order to ensure that each actual servo motor's movement begins at the same time. This control takes place through the Simple Motion module where the program is written in GX Works2 (which is a part of the iQ Works).

Application

Sealing takes place with absolute servo moves to seal the bottom of a bag, while simultaneously sealing the top of the bag that's already been filled. A blade moves to cut the material in order to release each finished bag from the tube. The bag then falls onto the exit belt to be carried away for boxing.

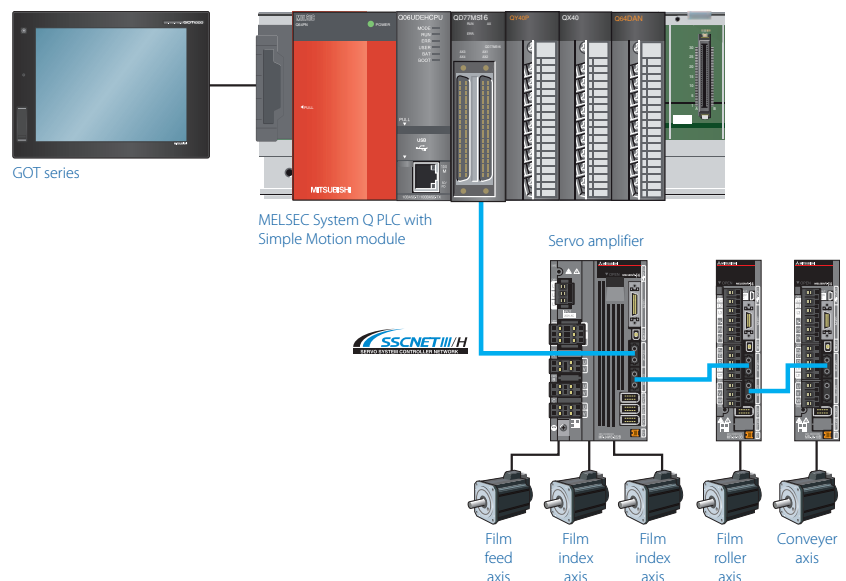
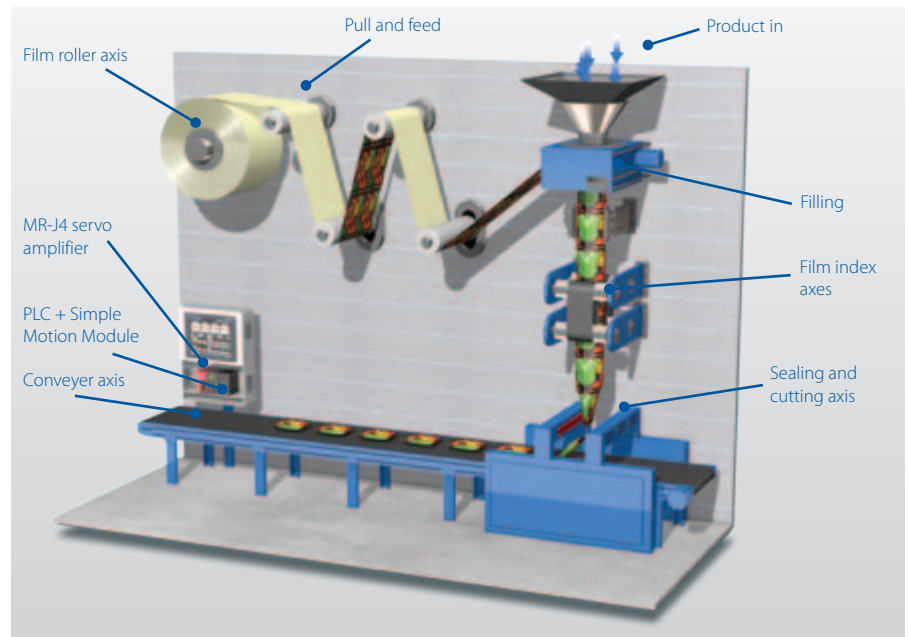

XY table application

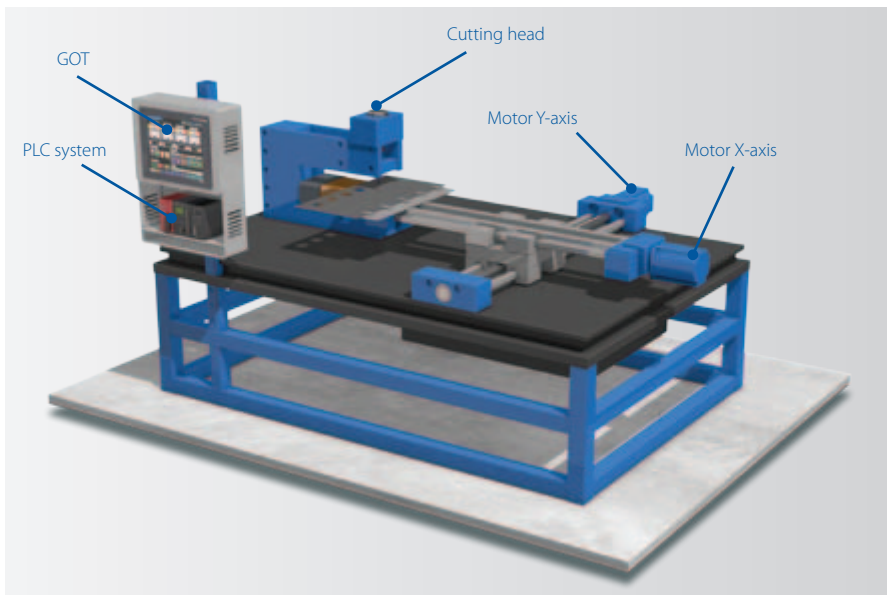

Overview

XY tables are used in a variety of applications with different positioning requirements. Usually horizontal motion involves 2 (or more) axes of servo performing linear or circular interpolation.

Which automation components are important

XY tables utilize servo motor technology for accurate positioning. The two servo motors are connected to a table to move the application in X and Y direction. The 2 motors are controlled by a MR-J4W2-B servo amplifier, which is the latest technology from Mitsubishi Electric. The movement and interpolation is calculated with the Simple Motion module.

In combination with a L Series PLC and its built in features, a complete solution can be offered with less components. Thanks to the SSCNETIII/H Network, all internal servo parameters can be set directly from the PLC.

Often the pattern information will be drawn on a CAD package and exported as a DXF file. The DXF file can be read directly into the G-CAD converter software to create a Simple Motion program to follow the motion path.

Application

In general, XY tables do not require a lot of maintenance, and are considered to be highly accurate and easy-to-use. However, mechanical parts can still be a problem after time. Depending on the weight of the load, ball screws within XY tables and other mechanical components can acquire a significant amount of wear and may need to be renewed regularly. Therefore, Mitsubishi Electric developed new functions to estimate frictions & vibrations which support preventative maintenance of machine components. These functions are integrated in the new MR-J4 series.

Additionally the G-CAD converter software package allows the user to import directly CAD files and move any pattern without modifying the PLC program.

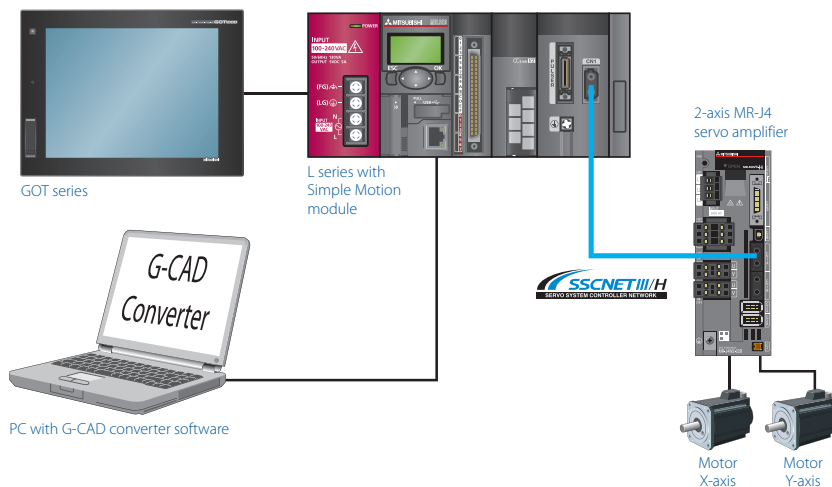

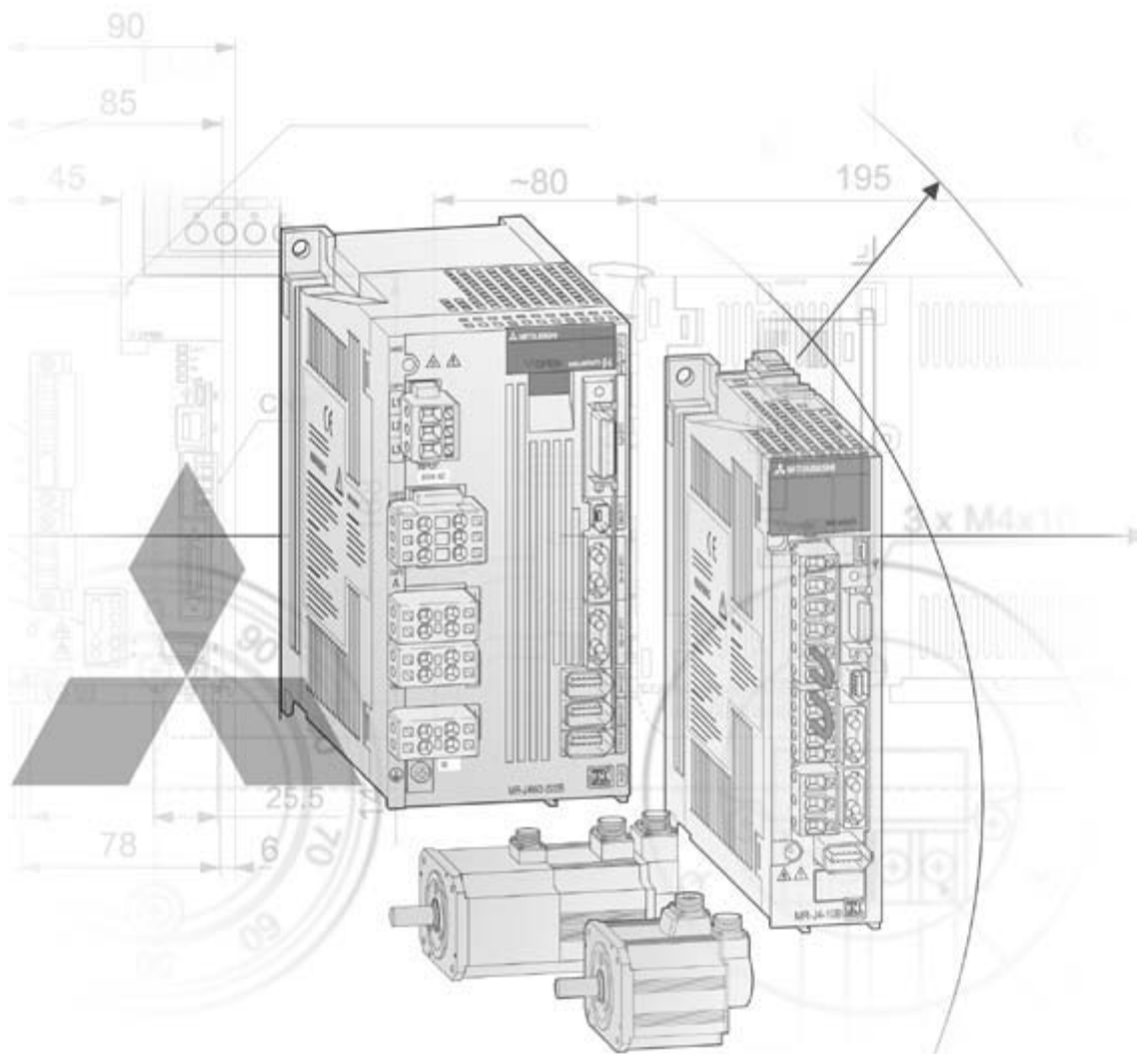

Technical Catalogue

Further Publications within the Mitsubishi Electric family

Brochures

Q/L Family

Product catalogues for modular programmable logic controllers and accessories for the MELSEC System Q and MELSEC L series

FX Family

Product catalogue for compact programmable logic controllers and accessories for the MELSEC FX family

HMI Family

Product catalogue for operator terminals, supervision software and accessories

FR Family

Product catalogue for frequency inverters and accessories

MELFA Family

Product catalogue for industrial robots and accessories

Low Voltage Switchgears

Product catalogue for low voltage switchgears, magnetic contactors and circuit breakers

Automation Book

Overview on all Mitsubishi Electric automation products, like frequency inverters, servo/motion, robots etc.

More information?

This product catalogue is designed to give an overview of the extensive range of MELSERVO amplifiers and motors. If you cannot find the information you require in this catalogue, there are a number of ways you can get further details on configuration and technical issues, pricing and availability.

For technical issues visit the <https://eu3a.mitsubishielectric.com> website. Our website provides a simple and fast way of accessing further technical data and up to the minute details on our products and services. Manuals and catalogues are available in several different languages and can be downloaded for free.

For technical, configuration, pricing and availability issues contact our distributors and partners. Mitsubishi Electric partners and distributors are only too happy to help answer your technical questions or help with configuration building. For a list of Mitsubishi Electric partners please see the back of this catalogue or alternatively take a look at the „contact us“ section of our website <https://eu3a.mitsubishielectric.com>.

About this product catalogue

This catalogue is a guide to the range of products available. For detailed configuration rules, system building, installation and configuration the associated product manuals must be read. You must satisfy yourself that any system you design with the products in this catalogue is fit for purpose, meets your requires and conforms to the product configuration rules as defined in the product manuals.

Specifications are subject to change without notice. All trademarks acknowledged.

© Mitsubishi Electric Europe B.V., Factory Automation - European Business Group

The products of Mitsubishi Electric Europe B.V., that are listed and described in this document, are neither subject to approval for export nor subject to the Dual-Use List.

1 System Description

- ◆ Servo and motion systems 4
- ◆ Overview of MELSERVO servo amplifier series 6
- ◆ Interface and function 7
- ◆ Advanced servo gain adjustment function..... 8
- ◆ Built-in positioning function, machine diagnosis function,
2-axis/3-axis types, supporting energy..... 9
- ◆ Servo motor and servo amplifier model designations 10

2 Servo Motors

- ◆ Description of the servo motors 13
- ◆ Servo motor specifications and matching amplifiers 16
- ◆ Servo motor without electromagnetic brake..... 18
- ◆ Servo motor with electromagnetic brake 27

3 Servo Amplifiers

- ◆ Specifications MR-JE 29
- ◆ Specifications MR-J4 30
- ◆ Specifications MR-J4W2-B/MR-J4W3-B..... 32
- ◆ Specifications MR-D30 33
- ◆ MR-J4-A servo amplifier connections with peripheral equipment..... 34
- ◆ MR-J4-B servo amplifier connections with peripheral equipment 35
- ◆ MR-JE servo amplifier connections with peripheral equipment 36

4 Options And Peripheral Equipment

- ◆ Connections with peripheral equipment 37
- ◆ Cables and connectors for servo motors (without electromagnetic brake) 44
- ◆ Cables and connectors for servo motors (with electromagnetic brake)..... 48
- ◆ Cables and connectors for servo amplifier MR-J4..... 49
- ◆ Cables and connectors for servo amplifier MR-JE..... 50
- ◆ Converter MR-ENCOM 50
- ◆ Buffer battery, terminal blocks and manual pulse generator 51
- ◆ EMC filters and brake resistors 52
- ◆ Software 53
- ◆ Positioning units..... 54
- ◆ Motion controller..... 58
- ◆ MELSEC System Q motion CPUs 60

5 Applications

- ◆ Configuration of a SSCNETIII/H System 61
- ◆ X-Y table system configurations 62

6 Dimensions

- ◆ Servo motors 63
- ◆ Servo amplifiers 69
- ◆ EMC filters..... 80
- ◆ Brake resistors 81
- ◆ Functional safety unit MR-D30, extension I/O unit MR-J3-D01 82

Appendix

- ◆ Index..... 83



Servo and Motion Systems

Mitsubishi Electric offers a variety of Servo and Motion system products providing solutions for applications covering point-to-point and synchronised systems. Systems can be built using a single axis or multi axes, for example when using a MELSEC System Q Motion CPU solution up to 96 axes can be controlled.

With both standard pulse type output modules and SSCNET bus modules specific application needs are easy to meet.

The Servo motors and amplifiers take Mitsubishi Electric Motion Control to new levels of precision with a wide range of motors and a wide range of amplifiers (up to 110 kW). All MR-JE series motors are fitted

with 131072 pulse-per-revolution encoders, all MR-J4 series motors with 262144 pulse-per-revolution encoders, all MR-J4 series motors with 4194304 pulse-per-revolution encoders.

All Mitsubishi Electric Servo and Motion system hardware is complimented by a range of software packages allowing easy programming and set-up of the units.

What are the components of a MR-J4 servo system?

Servo motors

Utilising the most advanced concentrated winding techniques and latest technology, these brushless servo motors are among the most compact on the market.

Mitsubishi Electric Servo Motors are made to high standards and offer a wide range of power, speed and inertia ratings providing a motor for all applications. With a range from 50 W to 110 kW and with a considerable number of motor types like rotary, linear and direct drive servo motors a complete line-up of products can be offered by Mitsubishi Electric.

Also, all motors in the MR-J4 series are fitted with absolute encoders as standard. Therefore, an absolute position system can be created by simply providing power to Servo amplifier via a battery. Once this has been done the super capacitor inside the motor and back-up battery allow the Servomotor position to be constantly monitored.

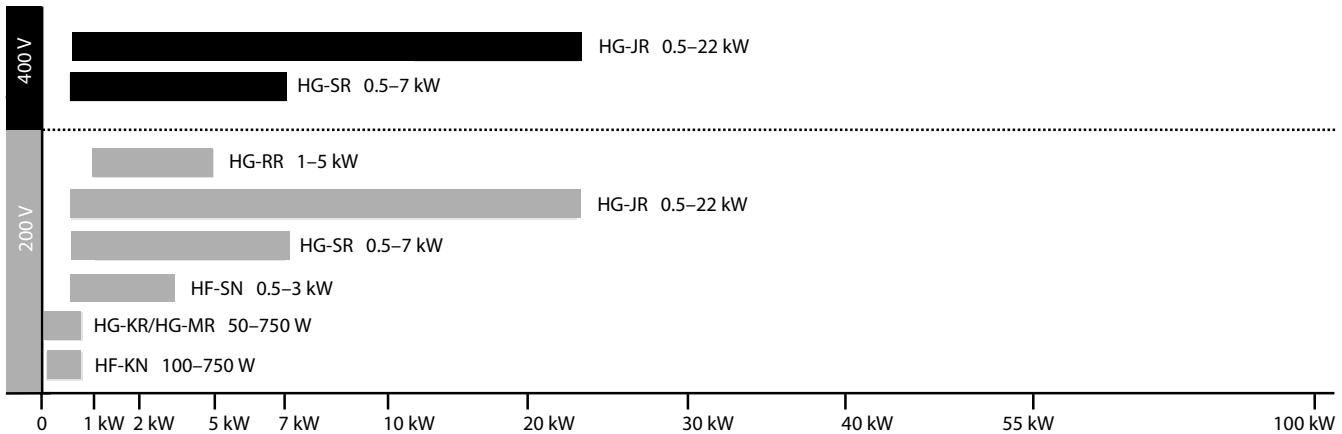

Improving machine performance with high-performance motors

To raise your machine on a high productive level, you need not only powerful servo amplifiers but also high performance servo motors. These motors have to support the high encoder resolution of 22 bits with the MR-J4 series for improved accuracy and speed. Fully closed loop control is supported as standard. A variety of models is available to match various applications.

Rotary servo motors achieve high-accuracy, high-torque output during high speed positioning and smooth rotation with a high resolution encoder and improved processing speed. Linear servo motors support highly accurate tandem synchronous control. Direct drive motors are used for compact and rigid machine and high-torque operations.

For rough environment conditions some motor series are also available with higher protection class like IP65 or IP67.

The MR-J4 series servo amplifiers are able to operate rotary servo motors, linear servo motors, and direct drive motors as standard.

[Resolution comparison with the prior model]

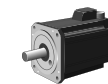
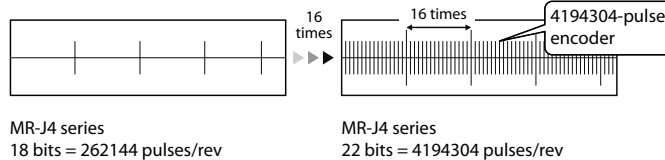

Rotary servo motor

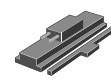

Linear servo motor

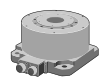

Direct drive motor

Servo amplifiers

Mitsubishi Electric offers a wide range of Servo amplifiers to meet the demands of all types of applications. From standard digital pulse and analogue controlled amplifiers through to dedicated SSCNETIII/H bus type amplifiers, there is a product for all circumstances.

Real Time Adaptive Tuning (RTAT) is a unique Mitsubishi Electric technology, enabling the servo to deliver maximum dynamic performance, even if the load keeps changing, by automatically tuning online (during operation) to the application.

The digital pulse-train and analogue units of the MR-JE and the MR-J4 series from 100 W to 22 kW. The SSCNETIII/H bus type amplifiers (type MR-J4-B) offer the user ease of connectivity, via SSCNETIII/H.

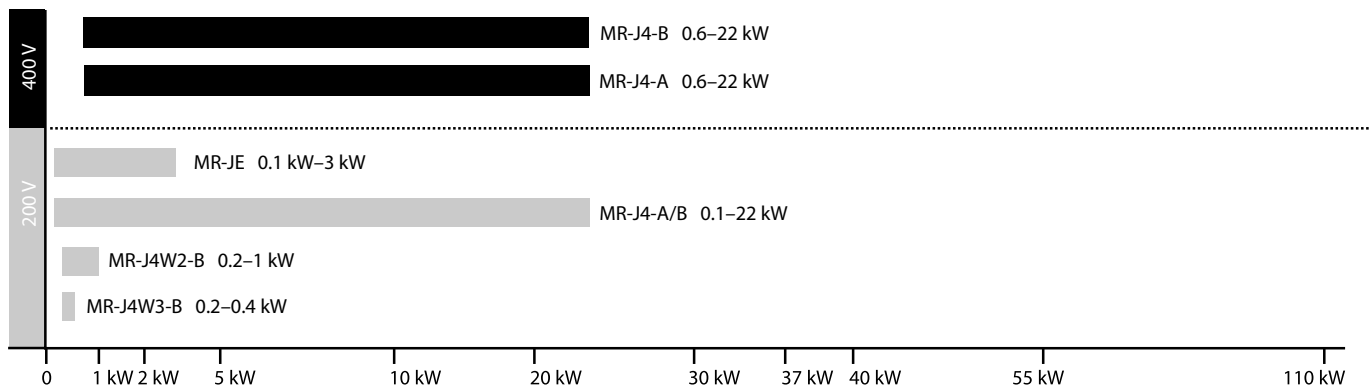

Positioning controllers

For the compact, cost effective, FX range of PLCs, the FX2N-10PG unit provides single-axis control with built-in positioning tables, fast external start and an output pulse rate of up to 1 MHz. The module FX3U-20SSC-H is a positioning module for the MR-J4-B series. This module provides a quick and easy, but efficient positioning control system for simpler applications.

For larger and more complex applications the L-series and the MELSEC System Q provide numerous positioning and Simple motion modules (1, 2, 4 and 16 axes).

These are: open-collector output type (LD75P/QD75P series), Differential output type (LD75D/QD75D series) and SSCNETIII bus type (FX3U-20SSC-H), SSCNETIII/H bus type (LD77MS/QD77MS). Using the SSCNETIII system can provide much improved, easier to use positioning systems, with reduced wiring and better noise immunity. All positioning modules provide functions such as interpolation, speed control and positioning operations, etc. For advanced motion applications like axes synchronisation and CAM control the Simple Motion modules (LD77/QD77) are available.

Motion Controllers

For specialist applications requiring the highest level of control and precision, the dynamic servo technology provided by the Q-Motion CPU is combined with the powerful processing power of the MELSEC System Q PLC CPU, creating a completely new generation of motion controller products.

This fully integrated and flexible system has the capability to control up to 96 axes using SSCNETIII/H, which is more than capable for handling any motion application.

MELSERVO MR-J4 Servo Amplifiers

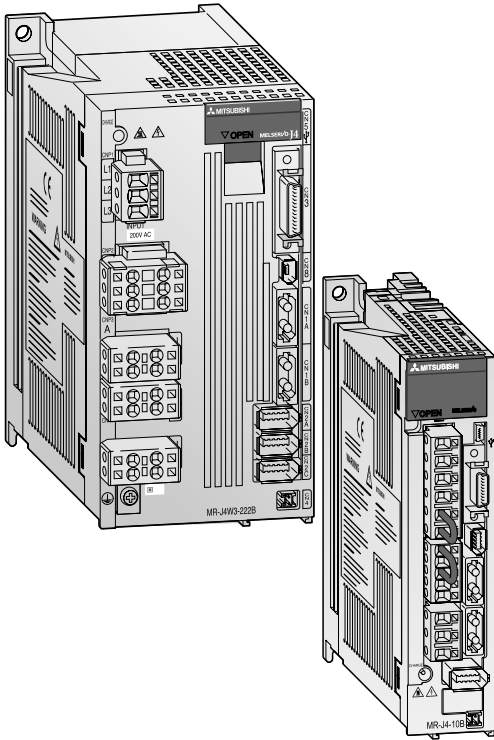

MELSERVO

The MR-J4 servo drive systems from Mitsubishi Electric combine extremely dynamic response with ultra-fast positioning. In addition the servo amplifiers are also very simple to use and their advanced functionality make it possible to achieve maximum performance very quickly,

even for users without special experience in calibrating drive applications. The significantly improved auto-tuning function reduces the need for the time-consuming trial-and-error approach. In combination with the setup software package (MR Configurator2) the MR-J4 series can be used to detect application mechanical critical frequencies. This enables notch filters to be set to avoid resonant frequencies enabling vibration-free operation.

When using amplifiers of competitors the controller response level has to be reduced for the entire operation range.

The MR-J4 servo amplifiers can be used for global applications with superb operation in the toughest environments.

Features

- High-performance CPU
- Adaptive vibration suppression control function for compensation for resonance up to five resonance frequencies
- Advanced vibration suppression control for compensation of motion overshoot
- Separate wiring of the control power supply
- High responsiveness
- One-Touch-Tuning
- Servo-lock anti-vibration function
- USB ports for connecting a PC (additional RS422 port at the MR-J4-A)
- Automatic motor recognition
- Network capability
- Complies with global industrial standards incl. CE, UL and cUL
- Integrated safety functions

Differences Between the Four MELSERVO Servo Amplifier Series

MR-J4-A (standard type)

The MR-J4-A series is ideal for servo applications using conventional control systems. The servo amplifiers have two analog inputs and numerous digital inputs for activating internal application functions (i.e. pulse train positioning). Using the digital pulse train method eliminates the problems inherent in analog control, such as offset shifts caused by temperature fluctuations and drifting when the system is at rest.

The MR-J4-A series can be used in torque, speed or position control mode.

Additionally, the MR-J4-A-RJ has a built-in positioning function. Simple positioning tasks can be implemented directly in the servo amplifier, a higher-level position control is not required

Highlights

- 2 analog inputs
- 1 digital pulse train input
- 7 preset speeds
- Supports three different types of pulse train signals: standard encoder signals (line driver or open collector); pulse and direction; pulse train for right and left rotation
- Positioning function additionally program or data tables
- Safety functions according to EN IEC 61800-5-2: „Safe Torque Off“ (STO) and „Safe Stop 1“ (SS1).

MR-J4-B (SSCNETIII/H network type)

The MR-J4-B series supports connection to Mitsubishi Electric motion control and positioning control systems. The drive systems are connected to these controllers via SSCNETIII/H, a high-speed motion network enabling high precision synchronization and advanced interpolation. The minimum cycle time of just 0.22 ms increases responsiveness and reduces tact cycle of machine due to fast data exchange. Setting up this plug-and-play network couldn't be easier; you just have to select the axis address and connect the preconfigured bus cable, which also makes wiring errors impossible.

Highlights

- Plug-and-play SSCNETIII/H network
- Motor brake can be controlled directly by the amplifier
- Emulated encoder outputs for connection of conventional slave drive systems
- Amplifier replacement is fast and simple because data management is performed by superior controller.
- Automatic position detection on power-up thanks to absolute position detection system (multi-turn absolute positioning is realised by optional back-up battery)
- Safety functions according to EN IEC 61800-5-2: „Safe Torque Off“ (STO) and „Safe Stop 1“ (SS1), Safe Brake Control (SBC), Safely Limited Speed (SLS), Safe Speed Monitor (SSM) additionally with the functional safety unit MR-D30 and the Servoamplifiers MR-J4-B-RJ.

MR-JE (general purpose type)

The servo system MR-JE-A can perform operation in different control modes, e.g. position/ internal speed control. It fits a wide range of applications such as precision positioning and smooth speed control of machine tools and general industrial machines (e.g. packaging, processing or labelling machines).

External analog speed command or torque command are implemented to use this servo system for applications in which speed or torque has to be smoothly controlled.

Up to 1 Mpps high-speed pulse train is used to control the speed and direction of the motor and execute precision positioning also taking advantage of the high encoder revolution of 131072 pulses/rev.

Highlights

- The compact dimensions enable flexible installation and economical design
- With an output range of 100 W–3 kW the system is suitable for any kind of application
- The system allows high accuracy positioning thanks to the integrated high resolution encoder (131072 pls/rev)
- It is a well-priced product for cost-effective and economical servo solutions
- Auto-tuning and diagnostic tools are available for easy and time-saving installation

**MR-J3-□A
(General-purpose interface compatible)**

Pulse train and analog input, etc., are provided as a standard for the command interface. The control mode can be switched accordingly for position, speed or torque control.

**MR-J3-□BSafety
(SSCNETIII compatible/Drive safety compatible/Fully closed loop control)**

STO (Safe torque off) function is provided as a safety function. SS1 function is also supported by using the optional module MR-J3-D05. Fully closed loop control is also supported.

**MR-J3-□T
(CC-Link compatible/Built-in positioning function)**

The built-in positioning function sets position and speed data in the point tables in the servo amplifier. Positioning operation can be started using start signals from a host controller.

**MR-J3-□A-EtherCAT
(EtherCAT compatible)**

This is an AC servo amplifier based on the MR-J3-□A series, and is compatible with high speed communication through the open network EtherCAT. The drive supports CANopen over EtherCAT (CoE) CiA402 Drive Profile with PDO communication cycle time of 500 μs, 1 ms, 2 ms.

Specifications	MR-J3-□A	MR-J3-□BSafety	MR-J3-□T	MR-J3-□A-EtherCAT
Command interface	Pulse train/Analog/RS422 multi-drop	SSCNETIII	CC-Link/DIO/RS422 multi-drop pulse train	EtherCAT
Control mode	Position/Speed/Torque	Position/Speed/Torque/Fully closed loop control	Position/Speed/Torque/ Built-in Positioning function	Home position return, Position, Speed
Power specifications	1-phase 200 V AC/ 3-phase 200 V AC/ 3-phase 400 V AC	1-phase 200 V AC/ 3-phase 200 V AC/ 3-phase 400 V AC	1-phase 200 V AC/ 3-phase 200 V AC/ 3-phase 400 V AC	1-phase 200 V AC/ 3-phase 200 V AC/ 3-phase 400 V AC
Capacity range	100 W to 55 kW	100 W to 55 kW	100 W to 22 kW	100 W to 22 kW

For order information, please contact your Mitsubishi Electric representative

A wide range of capacities and series for various system applications

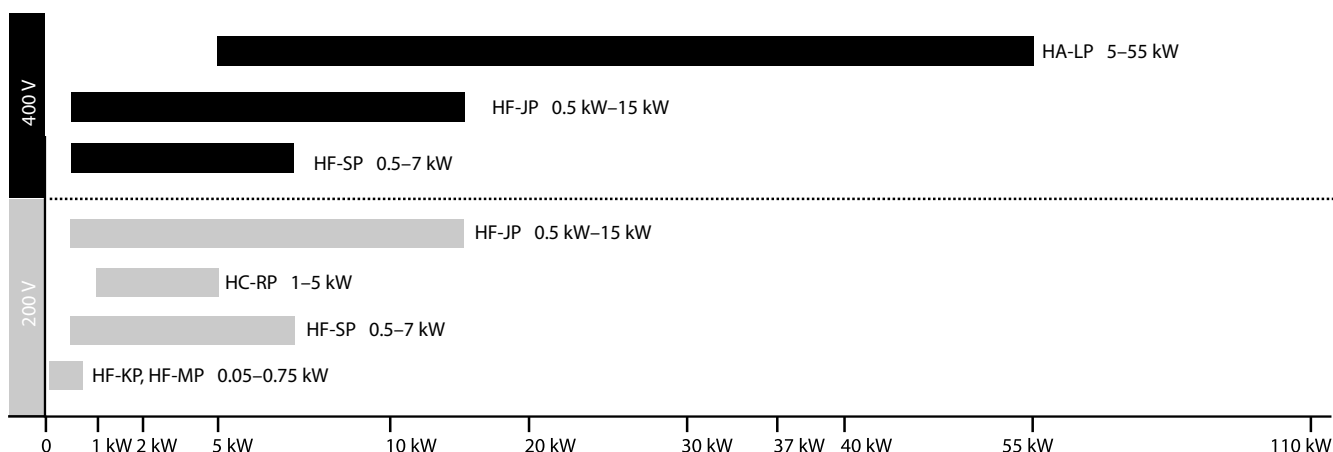

Advanced Servo Gain Adjustment Function

Advanced one-touch tuning function

Servo gains including machine resonance suppression filter, advanced vibration suppression control II, and robust filter are adjusted just by turning on

the one-touch tuning function. Machine performance is utilized to the fullest using the advanced vibration suppression control function.

Result is a vibration-free, high-precision and fast positioning process.

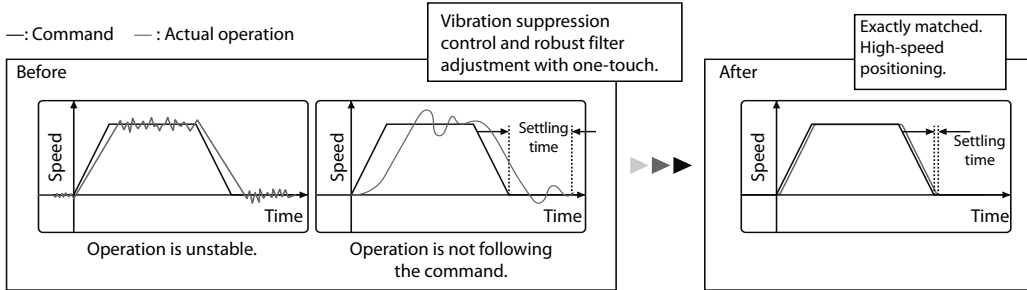

Advanced vibration suppression control II

Due to vibration suppression algorithm which supports three-inertia system, two types of low frequency vibrations are suppressed at

the same time. Adjustment is performed on MR Configurator2. This function is effective in suppressing vibration at the end of an arm and

in reducing residual vibration in a machine, enabling a shorter settling time.

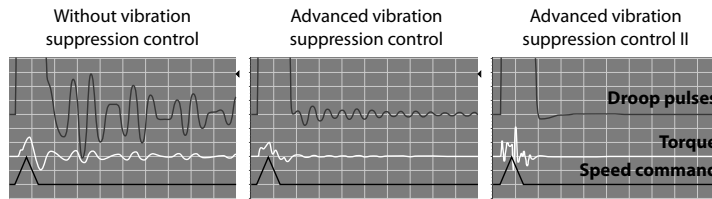
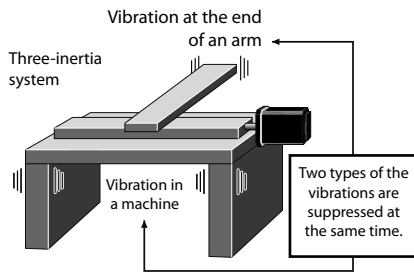

Machine resonance suppression filter

With advanced filter structure, applicable frequency range is expanded to between 10 Hz and 4500 Hz. Additionally, the number of simultaneously applicable filters is increased to five, improving vibration suppression performance of machines.

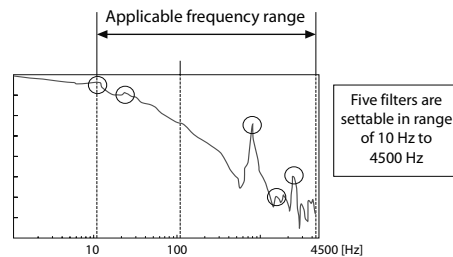

Robust filter

Achieving both high responsivity and stability was difficult with the conventional control in high-inertia systems with belts and roller such as printing and packaging machines. Now,

this function enables the high responsivity and the stability at the same time without adjustment. The robust filter more gradually reduces the torque with wide frequency range and

achieves more stability as compared to the prior model.

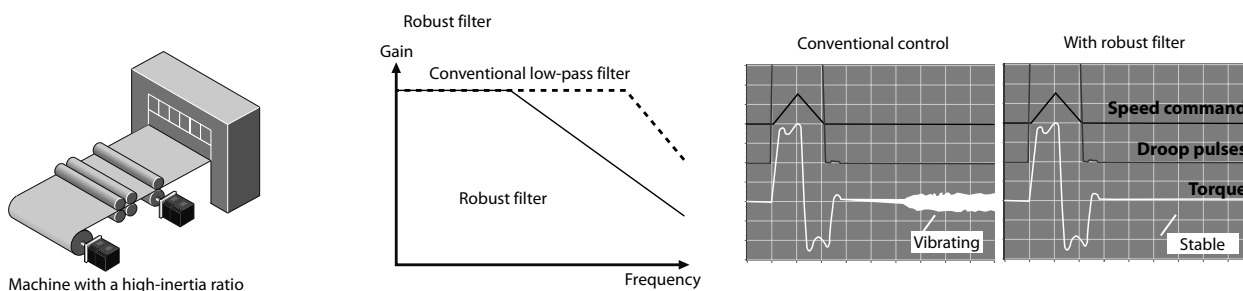

Servo Amplifier with Built-in Positioning Function

A simple positioning system can be configured without a controller (positioning module) since the positioning function (point table and program methods, and indexer positioning operation) is built into the MR-J4-A-RJ servo amplifier. Built-in positioning function. With the direct connection of an Graphic Operation Panel (GOT), the positioning operations can easily be adjusted. Of course all diagnostic functions of the GOT are available.

Built-in positioning function:

- Point table method
- Program method
- Indexer positioning operation

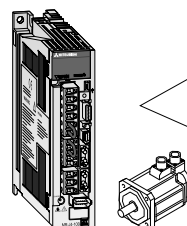

Point table method

Point Table No.	Position data	Servo motor speed	Acceleration time constant	Deceleration time constant	Deviat time	Auxiliary function
1	1000	2000	200	200	0	1
2	2000	1600	100	100	0	0
...

Setting position data (target position), servo motor speed, and acceleration and deceleration time in the point table is as easy as setting parameters.

Program method
Positioning operation is performed according to the program that is created in advance. For this purpose 25 instructions are provided in the servo amplifier.

```

Program No.1
SPN (2000)
STC (20)
MOV (1000)
TMI (100)
FOR (3)
MOVH (100)
TMI (100)
NEXT
STOP
    
```

Indexer
Positioning to a set number of equally divided stations is possible.

Machine Diagnosis Function

This function detects changes of machine parts (ball screw, guide, bearing, belt, etc.) by analyzing machine friction, load moment of inertia, unbalanced torque, and changes in vibration component from the data inside the servo amplifier, supporting timely maintenance of the driving parts.

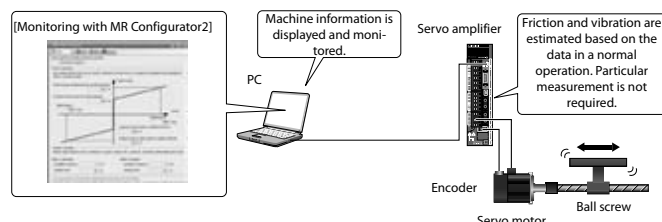

2-axis/3-axis Types for Energy-conservative, Miniaturized, and Low-cost Machine

2-axis and 3-axis servo amplifiers are available for operating two and three servo motors, respectively. These servo amplifiers enable energy-conservative, compact machine at lower cost. Different types of servo motors including rotary servo motors, linear servo motors, and direct drive motors are freely combined as long as the servo motors are compatible with the servo amplifier.

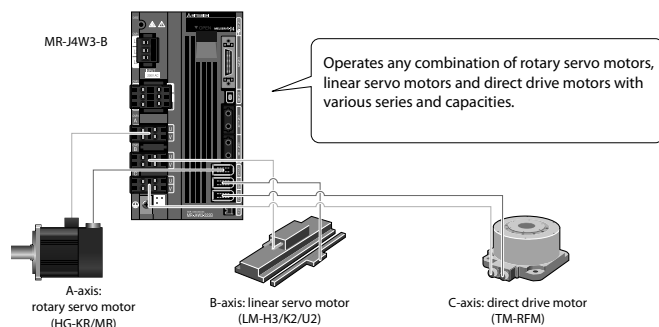

Supporting Energy-conservative Machine Using Regenerative Energy

In the multi-axis servo amplifier, the regenerative energy of an axis is used as driving power energy for the other axes, contributing to energy-conservation of machine. Reusable regenerative energy stored in the capacitor is increased for MR-J4W2-B/MR-J4W3-B as compared to the prior model. Regenerative option is no longer required.

In the multi-axis servo amplifier, the amount of temporarily stored regenerative energy can be increased by using a capacitor bank. (Available in the future) Contact your local sales office for more details.

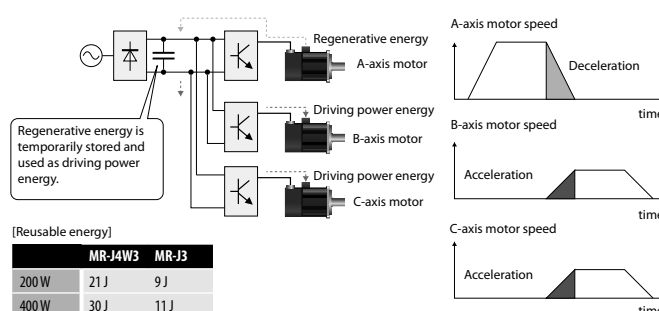

Servo Amplifiers Model Designation

1
System Description

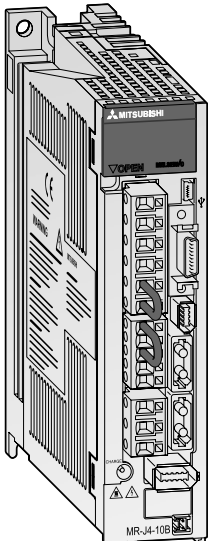

MR-J4-A/B

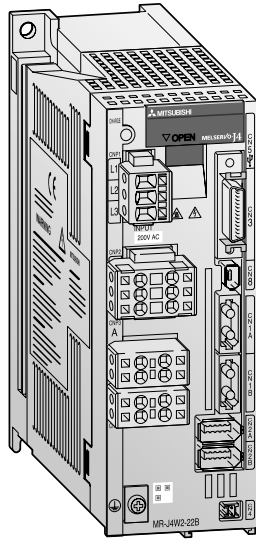

MR-J4W2-B

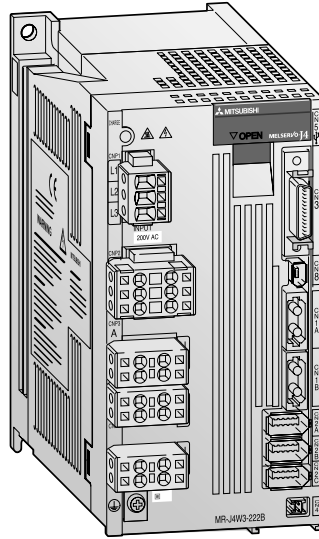

MR-J4W3-B

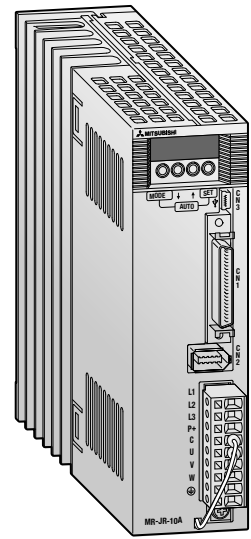

MR-JE

Servo amplifiers 200 V

MR-J4-□A/B -RJ

Series	Compatible servomotors					Code	Type	Code	Type	Code	Type	
	Code	HG-MR□	HG-KR□	HG-SR□	HG-JR□							HG-RR□
MR-J4	10	053/13	053/13	—	—	—	A	Standard general-purpose	—	200–230 V AC power supply	—	Standard
	20	23	23	—	—	—	B	SSCNETIII/H compatible	—		A-RJ ^②	Integrated positioning
	40	43	43	—	—	—					B-RJ ^②	Extended Safety functions via functional safety unit MR-D30
	60	—	—	52	53	—						
	70	73	73	—	73	—						
	100	—	—	102	53 ^① /103	—						
	200	—	—	152/202	73 ^① /103 ^① /153/203	103/153						
	350	—	—	352	153 ^① /203 ^① /353	203						
	500	—	—	502	353 ^① /503	353/503						
	700	—	—	702	503 ^① /703	—						
	11K	—	—	—	903/11K1M	—						
	15K	—	—	—	15K1M	—						
	22K	—	—	—	22K1M	—						

① This combination increases the maximum torque from 300% to 400% of the rated torque.
② Additional input for external encoder

Servo amplifiers 400 V

MR-J4-□A/B4-RJ

Series	Compatible servomotors		Code	Type	Code	Type	Code	Type	
	Code	HG-SR□							HG-JR□
MR-J4	60	524	534	A	Standard general-purpose	4	380–480 V AC power supply	—	Standard
	100	1024	534 ^① /734 ^① /1034	B	SSCNETIII/H compatible			A-RJ ^②	Integrated positioning
	200	1524/2024	734 ^① /1034 ^① /1534/2034					B-RJ ^②	Extended Safety functions via functional safety unit MR-D30
	350	3524	1534 ^① /2034 ^① /3534						
	500	5024	3534 ^① /5034						
	700	7024	5034 ^① /7034						
	11K	—	9034/11K1M4						
	15K	—	15K1M4						
	22K	—	22K1M4						

① This combination increases the maximum torque from 300% to 400% of the rated torque.
② Additional input for external encoder

All amplifiers conform to the following standards: CE, UL, cUL

MR-J4W2-□B

Series	Code	Anzahl Achsen	Compatible servomotors				Code	Type	Code	Type	
MR-J4	W2	2 Achsen	Code	HG-MR□	HG-KR□	HG-SR□	HG-JR□	B	SSCNETIII/H compatible	—	200–230 V AC power supply
			22	053/13/23	053/13/23	—	—				
			44	053/13/23/43	053/13/23/43	—	—				
			77	43/73	43/73	52	53/73				
			1010	43/73	43/73	52/102	53/73/103				

MR-J4W3-□B

Series	Code	Anzahl Achsen	Compatible servomotors				Code	Type	Code	Type	
MR-J4	W3	3 Achsen	Code	HG-MR□	HG-KR□	HG-SR□	HG-JR□	B	SSCNETIII/H compatible	—	200–230 V AC power supply
			222	053/13/23	053/13/23	—	—				
			444	053/13/23/43	053/13/23/43	—	—				

MR-JE-□A

Series	Compatible servomotors		Code	Ausführung	
MR-JE	Code	HF-KN□	HF-SN□	A	Standard general-purpose
	10	13	—		
	20	23	—		
	40	43	—		
	70	73	52		
	100	—	102		
	200	—	152/202		
	300	—	302		

All amplifiers conform to the following standards: CE, UL, cUL

Servo Motors Model Designation

HG-MR series

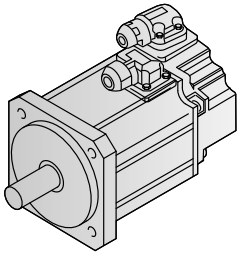

HG-KR series

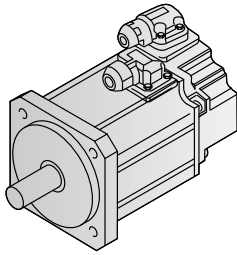

HG-SR series

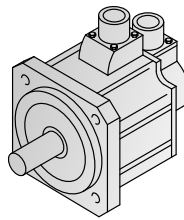

HG-RR series

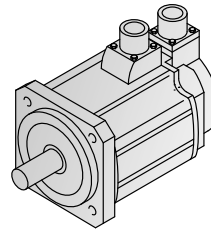

HG-JR series

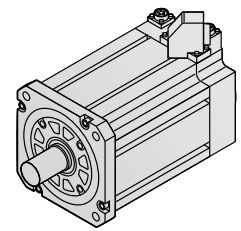

Servo motors 200 V

HG-KR □ □ □

Symbol	Motor series
HF-KN	Low inertia, small capacity
HF-SN	Medium inertia, medium capacity
HG-MR	Ultra-low inertia, small capacity
HG-KR	Low inertia, small capacity
HG-RR	Ultra-low inertia, medium capacity
HG-JR	Low inertia, medium capacity
HG-SR	Medium inertia, medium capacity

Code	Rated output [W]	Code	Rated output [W]
05	50	10	1000
1	100	15	1500
2	200	20	2000
4	400	35	3500
5	500	50	5000
7	750	70	7000

Code	Rated speed [rpm]
2	2000
3	3000

Code	Electromagnetic brake
—	—
B	●

All motors conform to the following standards:
CE, UL, cUL

Example: HG-MR 053 B = Ultra-low inertia type with small capacity; 50 W; 3000 rpm; 200 V; with electromagnetic brake

Servo motors 400 V

HG-SR □ □ 4 □

Symbol	Motor series
HG-JR	Low inertia, medium capacity
HG-SR	Medium inertia, medium capacity

Code	Rated output [W]	Code	Rated output [W]
5	500	50	5000
10	1000	70	7000
15	1500	11k	11000
20	2000	15k	15000
35	3500	22k	22000

Code	Rated speed [rpm]
1M	1500
2	2000
3	3000

Code	Typ
4	400V

Code	Electromagnetic brake
—	—
B	●

Example: HG-SR 702 4B = Medium inertia type with medium capacity; 7000 W; 2000 rpm; 400 V; with electromagnetic brake

General note: The above tables show the motor model name break-down. Not all combinations are possible. Please refer to the motor specifications table on page 13

Servo Motor Features and Typical Applications

Absolute high-resolution encoder as standard equipment

Inclusion of an absolute position detection system eliminates the need for a homing sequence, approximate DOG and other sensors, helping to reduce time and enhance reliability. With these motors high performance and safety at low speed is ensured.

With Mitsubishi Electric original absolute mode, an absolute system can be configured using conventional I/O even with pulse-train control.

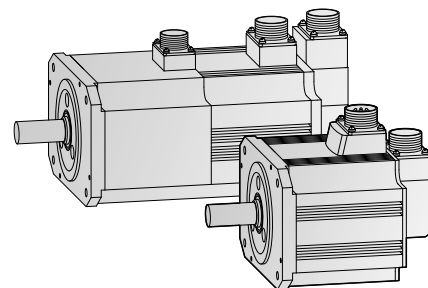

Overview

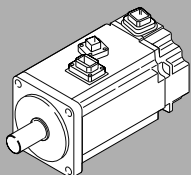
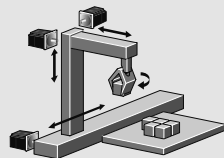
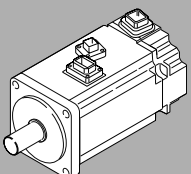
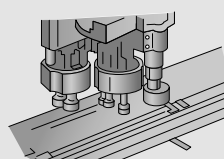
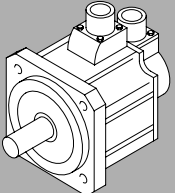
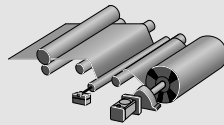
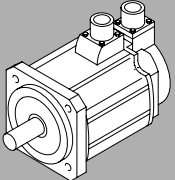
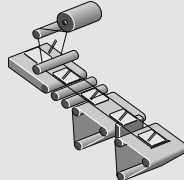
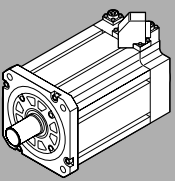
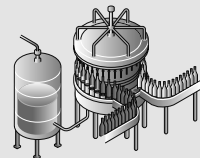
Model designation	Features	Application example
K 	Low inertia Larger motor inertia moment makes this unit well suited for machines with fluctuating load inertia moment or machines with low rigidity such as conveyors.	<ul style="list-style-type: none"> ● Conveyors ● Food preparation machinery ● Printers ● Small loaders and unloaders ● Small robots and component assembly devices ● Small X-Y tables ● Small press feeders  <p>Handling systems</p>
M 	Ultra low inertia Small motor inertia moment makes this unit well suited for high-dynamic positioning operations with extra small cycle times.	<ul style="list-style-type: none"> ● Inserters, mounters, bonders ● Printed board hole openers ● In-circuit testers ● Label printers ● Knitting and embroidery machinery ● Ultra-small robots and robot tips  <p>Inserters, mounters, bonders</p>
S 	Medium inertia Stable control is performed from low to high speeds, enabling this unit to handle a wide range of applications (e.g. direct connection to ball screw components).	<ul style="list-style-type: none"> ● Conveyor machinery ● Specialised machinery ● Robots ● Loaders and unloaders ● Winders and tension devices ● Turrets ● X-Y tables ● Test devices  <p>Winders and tension devices</p>
R 	Low inertia A compact sized low-inertia moment model with medium capacity. Well suited for high-frequency operation.	<ul style="list-style-type: none"> ● Roll feeders ● Loaders and unloaders ● High-frequency conveyor machinery 
J 	Low Inertia (400 V) A 400 V Servo Motor for the MELSERVO-J4 Series for a power range up to 22 kW with low inertia and high speed. It has a compact size, is equipped with high resolution encoder and is compatible to global standards.	<ul style="list-style-type: none"> ● Food and Packaging ● Printing machine ● Pick up robot for Injection molding machine ● Palletizing machine ● General machine which require High speed and High frequency  <p>Wrapping machinery</p>

Note: Other types of motors are available on request.

Achieving High-performance Machine

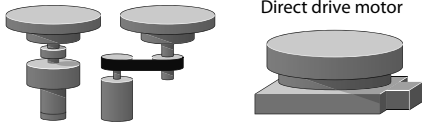
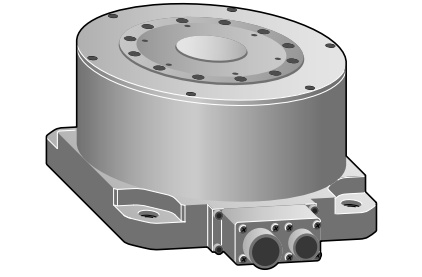

Direct drive motor

Conventional motor + transmission mechanism (gear, belt, etc.)

For higher machine performance

- Suitable for low-speed and high-torque operations.
- High-accuracy positioning is achieved because the motor is directly connected to the driving part.

For easier use

- Since transmission mechanism is no longer required, no backlash and no abrasion occurs, enabling smooth operation with less audible noise, clean system, and easy maintenance.
- Less components are required for the system.

For flexible machine configurations

- Simple, compact, and rigid machine is achieved.
- Machine stability is enhanced due to the low-profile design and a low center of gravity.
- The motor has an inner rotor with hollow shaft that allows cables and pipes to pass through.

Product lines

Motor series 200 V	Maximum rotation speed [r/min]	Rated speed [r/min]	Maximum rotation speed [r/min]	Rated torque [Nm] 1	Peak running range [Nm]	Moment of inertia J [x10 ⁻⁴ kg m ²]	Rated output capacity [kW]	Servo motor model	Servo motor type		Amplifier pairing MR-J4A/B						MR-J4W2B		MR-J4W3B				
									Voltage	Protective structure	10	20	40	60	70	100	200	350	500	22	44	77	1010
TM	130	200	500	2	6	10.9	0.042	TM-RFM002C20	200 V AC	IP42													
				4	12	16.6	0.084	TM-RFM004C20															
				6	18	22.4	0.126	TM-RFM006C20															
				6	18	74.0	0.126	TM-RFM006E20															
	180	200	500	12	36	111	0.251	TM-RFM012E20															
				18	54	149	0.377	TM-RFM018E20															
				12	36	238	0.251	TM-RFM012G20															
	230	200	500	48	144	615	1.005	TM-RFM048G20															
				72	216	875	1.508	TM-RFM072G20															
				40	120	1694	0.419	TM-RFM040J10															
330	100	200	120	360	3519	1.257	TM-RFM120J10																
			240	720	6303	2.513	TM-RFM240J10																

① When unbalanced torque is generated, such as in a vertical lift machine, be sure to use the absolute position detection system. It is also recommended that the unbalanced torque be kept under 70 % of the servo motor rated torque. Please contact your Mitsubishi Electric sales representative if necessary.

Application examples

Index table for machine tools

Rotary axis for material handling robots

Painting and vapor deposition systems

LCD/semiconductor spin-type cleaning systems

Testing systems (XY tables)

Rotary axis for polishing systems

Linear Servo Motor

LM-H3 series

Core type suitable for spacesaving. The magnetic attraction force contributes to high rigidity.

LM-F series

Core type compact linear servo motor. The integrated liquidcooling system doubles the continuous thrust. The magnetic attraction force contributes to high rigidity.

LM-K2 series

Core type with magnetic attraction counter-force. The magnetic attraction counter-force structure extends life of the linear guides and contributes to lowering audible noise.

LM-U2 series

Coreless type without cogging resulting in small speed fluctuation. The structure with no magnetic attraction force extends life of the linear guides.

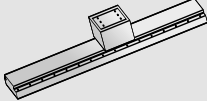
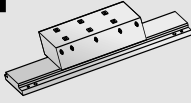
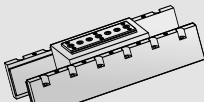
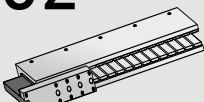
Motor series	Maximum speed [m/s]	Continuous thrust [N]	Servomotor		Servo motor type		Amplifier pairing MR-J4A/B																			
			Primary side (coil)	Secondary side (magnet)	Voltage	Protective structure	MR-J4W2B										MR-J4W3B									
							10	20	40	60	70	100	200	350	500	700	11K	15K	22K	22	44	77	1010	222	444	
H3 	3.0	70	LM-H3P2A-07P-BSSO	LM-H3S20-288-BSSO, LM-H3S20-384-BSSO, LM-H3S20-480-BSSO, LM-H3S20-768-BSSO	200 V AC	IP00	●											●	●	●	●					
	3.0	120	LM-H3P3A-12P-CSSO	LM-H3S30-288-CSSO, LM-H3S30-384-CSSO, LM-H3S30-480-CSSO, LM-H3S30-768-CSSO					●										●	●	●	●				
		240	LM-H3P3B-24P-CSSO						●											●	●	●	●			
		360	LM-H3P3C-36P-CSSO							●											●	●	●	●		
		480	LM-H3P3D-48P-CSSO								●										●	●	●	●		
	3.0	240	LM-H3P7A-24P-ASSO	LM-H3S70-288-ASSO, LM-H3S70-384-ASSO, LM-H3S70-480-ASSO, LM-H3S70-768-ASSO																	●	●				
		480	LM-H3P7B-48P-ASSO																			●	●			
		720	LM-H3P7C-72P-ASSO																				●	●		
		960	LM-H3P7D-96P-ASSO																					●	●	
F 	2.0	300	LM-FP2B-06M-1SSO	LM-FS20-480-1SSO, LM-FS20-576-1SSO			400 V AC	IP00																		
	2.0	600	LM-FP2D-12M-1SSO																							
		900	LM-FP2F-18M-1SSO																							
		600	LM-FP4B-12M-1SSO																							
		1200	LM-FP4D-24M-1SSO	LM-FS40-480-1SSO, LM-FS40-576-1SSO																						
	2.0	1800	LM-FP4F-36M-1SSO																							
		2400	LM-FP4H-48M-1SSO																							
		2.0	3000	LM-FP5H-60M-1SSO	LM-FS50-480-1SSO, LM-FS50-576-1SSO																					
K2 		2.0	120	LM-K2P1A-01M-2SS1	LM-K2S10-288-2SS1, LM-K2S10-384-2SS1, LM-K2S10-480-2SS1, LM-K2S10-768-2SS1	200 V AC	IP00																			
	2.0	360	LM-K2P1C-03M-2SS1																							
		240	LM-K2P2A-02M-1SS1	LM-K2S20-288-1SS1, LM-K2S20-384-1SS1, LM-K2S20-480-1SS1, LM-K2S20-768-1SS1																						
		720	LM-K2P2C-07M-1SS1																							
		1200	LM-K2P2E-12M-1SS1																							
	2.0	1400	LM-K2P3C-14M-1SS1	LM-K2S30-288-1SS1, LM-K2S30-384-1SS1, LM-K2S30-480-1SS1, LM-K2S30-768-1SS1																						
	2.0	2400	LM-K2P3E-24M-1SS1																							
U2 	2.0	50	LM-U2PAB-05M-0SSO	LM-U2SA0-240-0SSO, LM-U2SA0-300-0SSO, LM-U2SA0-420-0SSO	200 V AC	IP00	●																			
	2.0	100	LM-U2PAD-10M-0SSO																							
		150	LM-U2PAF-15M-0SSO																							
		75	LM-U2PBB-07M-1SSO	LM-U2S80-240-1SSO, LM-U2S80-300-1SSO, LM-U2S80-420-1SSO																						
		150	LM-U2PBD-15M-1SSO																							
	225	LM-U2PBF-22M-1SSO																								
	400	LM-U2P2B-40M-2SSO																								
	2.0	600	LM-U2P2C-60M-2SSO	LM-U2S20-300-2SSO, LM-U2S20-480-2SSO																						
	800	LM-U2P2D-80M-2SSO																								

Please contact your Mitsubishi Electric sales representative if necessary.

Application examples

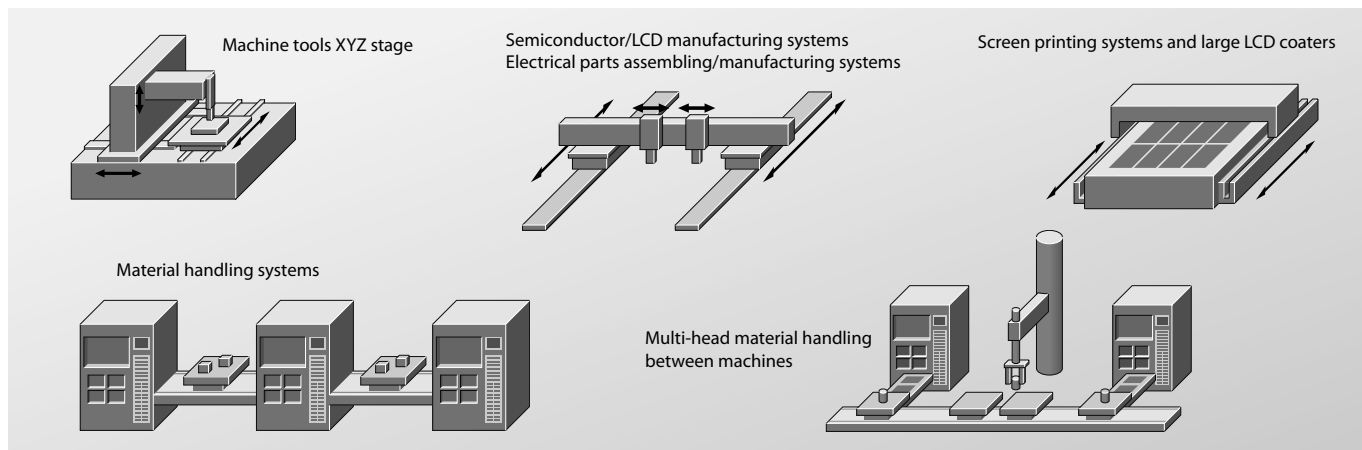

Servo Motor Specifications and Matching Amplifiers

The possible combinations of servo amplifiers and servo motors are listed in the table below.

Details of the braked version motors is given on page 27–28.

The detailed specifications of all servo motors are listed on the following pages.

Motors for MR-J4 (200 V) series servo amplifiers

Motor series 200 V	Rated speed [r/min]	Maximum rotation speed [r/min]	Rated torque [Nm]	Peak running range [Nm]	Moment of inertia J [x10 ⁻⁴ kg m ²]	Rated output capacity [kW]	Servo motor model	Servo motor type		Amplifier pairing MR-J4											Art. no.					
								Voltage	Protective structure	10	20	40	60	70	100	200	350	500	700	11K		15K	22K			
HG-MR M	3000	6000	0.16	0.48	0.0162	0.05	HG-MR053	200 V AC	IP65	●													248661			
			0.32	0.95	0.0300	0.10	HG-MR13			●														248662		
			0.64	1.9	0.0865	0.20	HG-MR23				●														248663	
			1.3	3.8	0.142	0.40	HG-MR43					●													248664	
			2.4	7.2	0.586	0.75	HG-MR73						●													248665
HG-KR K	3000	6000	0.16	0.56	0.0450	0.05	HG-KR053	200 V AC	IP65	●													248651			
			0.32	1.1	0.0777	0.10	HG-KR13			●														248652		
			0.64	2.2	0.221	0.20	HG-KR23				●														248653	
			1.3	4.5	0.371	0.40	HG-KR43					●													248654	
			2.4	8.4	1.26	0.75	HG-KR73						●													248655
HG-SR S	2000	3000	2.4	7.2	7.26	0.50	HG-SR52	200 V AC	IP67				●										248671			
			4.8	14.3	11.6	1.00	HG-SR102							●										248672		
			7.2	21.5	16.0	1.50	HG-SR152								●										248673	
			9.5	28.6	46.8	2.00	HG-SR202									●										248674
			16.7	50.1	78.6	3.50	HG-SR352										●									248675
			23.9	71.6	99.7	5.00	HG-SR502											●								248676
			33.4	100	151	7.00	HG-SR702												●							248677
HG-JR J	3000	6000	1.6	4.8 <6.4> ^①	1.52	0.5	HG-JR53	200 V AC	IP67 ^④				●		● ^②								261539			
			2.4	7.2 <9.6> ^①	2.09	0.75	HG-JR73						●		● ^②									261540		
			3.2	9.6 <12.7> ^①	2.65	1.0	HG-JR103							●		● ^②									261541	
			4.8	14.3 <19.1> ^①	3.79	1.5	HG-JR153								●		● ^②									261542
			6.4	19.1 <25.5> ^①	4.92	2.0	HG-JR203									●		● ^②								261543
			10.5	32.0 <44.6> ^①	13.2	3.3 <3.5> ^③	HG-JR353										●		● ^{②③}							261544
			15.9	47.7 <63.7> ^①	19.0	5.0	HG-JR503											●		● ^②						261545
	1500	3000	22.3	66.8	43.3	7.0	HG-JR703										●						261546			
			28.6	85.8	55.8	9.0	HG-JR903												●				261547			
		2500	70.0	210	220	11	HG-JR11K1M													●			261557			
			95.5	286	315	15	HG-JR15K1M														●			261558		
HG-RR R	3000	4500	3.2	8.0	1.50	1.0	HG-RR103	200 V AC	IP65														262896			
			4.8	11.9	1.90	1.5	HG-RR153																	262897		
			6.4	15.9	2.30	2.0	HG-RR203																		262898	
			11.1	27.9	8.30	3.5	HG-RR353																		262899	
			15.9	39.8	12.0	5.0	HG-RR503																			262900

- ① The value in angle brackets is applicable when the maximum torque is increased. The maximum torque will be increased by changing the servo amplifier to be combined (see ②).
- ② This combination of the HG-JR servo motor and the servo amplifier increases the maximum torque from 300% to 400% of the rated torque.
- ③ The value in angle brackets is applicable when the servo motor is used with MR-J4-500B or MR-J4-500A.
- ④ 22 kW of HG-JR series is rated IP44

Motors for MR-J4 (400 V) series servo amplifiers

Motor series 400 V	Rated speed [r/min]	Maximum rotation speed [r/min]	Rated torque [Nm]	Peak running range [Nm]	Moment of inertia J [x10 ⁻⁴ kg m ²]	Rated output capacity [kW]	Servo motor model	Servo motor type		Amplifier pairing MR-J4										
								Voltage	Protective structure	60	100	200	350	500	700	11K	15K	22K	Art. no.	
HG-SR S	2000	3000	2.4	7.2	7.26	0.5	HG-SR524	400 V AC	IP67	●									261431	
			4.8	14.3	11.6	1.0	HG-SR1024				●								261432	
			7.2	21.5	16.0	1.5	HG-SR1524					●							261433	
			9.5	28.6	46.8	2.0	HG-SR2024						●						261434	
			16.7	50.1	78.6	3.5	HG-SR3524							●					261435	
			23.9	71.6	99.7	5.0	HG-SR5024								●				261436	
			33.4	100	151	7.0	HG-SR7024									●			261437	
HG-JR J	3000	6000	1.6	4.8 <6.4> ^①	1.52	0.5	HG-JR534	400 V AC	IP67 ^④	●	● ^②								261445	
			2.4	7.2 <9.6> ^①	2.09	0.75	HG-JR734				●	● ^②							261446	
			3.2	9.6 <12.7> ^①	2.65	1.0	HG-JR1034				●	● ^②							261447	
			4.8	14.3 <19.1> ^①	3.79	1.5	HG-JR1534					●	● ^②						261448	
			6.4	19.1 <25.5> ^①	4.92	2.0	HG-JR2034					●	● ^②						261449	
			10.5	32.0 <44.6> ^①	13.2	3.3 <3.5> ^③	HG-JR3534						●	● ^{②③}					261450	
			15.9	47.7 <63.7> ^①	19.0	5.0	HG-JR5034							●	● ^②				261451	
		5000	22.3	66.8	43.3	7.0	HG-JR7034								●				261452	
			28.6	85.8	55.8	9.0	HG-JR9034									●			261453	
		1500	3000	70.0	210	220	11			HG-JR11K1M4							●			261384
				95.5	286	315	15			HG-JR15K1M4								●		261535
				140	420	489	22			HG-JR22K1M4									●	261536

- ① The value in angle brackets is applicable when the maximum torque is increased. The maximum torque will be increased by changing the servo amplifier to be combined (see ②).
- ② This combination of the HG-JR servo motor and the servo amplifier increases the maximum torque from 300 % to 400 % of the rated torque.
- ③ The value in angle brackets is applicable when the servo motor is used with MR-J4-500B or MR-J4-500A.
- ④ 22 kW of HG-JR series is rated IP44

Motors for MR-JE series servo amplifiers

Motor series 200 V	Rated speed [r/min]	Maximum rotation speed [r/min]	Rated torque [Nm]	Peak running range [Nm]	Moment of inertia J [x10 ⁻⁴ kg m ²]	Rated output capacity [kW]	Servo motor model	Servo motor type		Amplifier pairing MR-JE								
								Voltage	Protective structure	10A	20A	40A	70A	100A	200A	300A	Art. no.	
HF-KN K	3000	4500	0.32	0.95	0.088	0.1	HF-KN13	200 V AC	IP65	●								239797
			0.64	1.9	0.24	0.2	HF-KN23K				●						253946	
			1.3	3.8	0.42	0.4	HF-KN43K					●					253947	
			2.4	7.2	1.43	0.75	HF-KN73JK						●				253948	
			2.39	7.16	6.1	0.5	HF-SN52JK							●			253952	
HF-SN S	2000	3000	4.77	14.3	11.9	1.0	HF-SN102JK	200 V AC	IP67						●			253953
			7.16	21.5	17.8	1.5	HF-SN152JK								●		253954	
			9.55	28.6	38.3	2.0	HF-SN202JK									●	253965	
			14.3	42.9	58.5	3.0	HF-SN302JK										●	269030

HF-KN(B) Series Servo Motor Specifications (200 V Type)

Servo motor model	HF-KN13(B) ⑥	HF-KN23(B)K ⑥	HF-KN43(B)K ⑥	HF-KN73(B)JK ⑥
Servo amplifier model	MR-JE-10A	MR-JE-20A	MR-JE-40A	MR-JE-70A
Power facility capacity ①	[kVA] 0.3	0.5	0.9	1.3
Continuous characteristics	rated output [kW]	0.1	0.2	0.4
	rated torque [Nm]	0.32	0.64	1.3
Maximum torque [Nm]	0.95	1.9	3.8	7.2
Rated rotation speed [rpm]	3000	3000	3000	3000
Maximum rotation speed [rpm]	4500	4500	4500	4500
Permissible instantaneous rotation speed [rpm]	5175	5175	5175	5175
Power rate at continuous rated torque [kW/s]	11.5	16.9	38.6	39.9
Rated current [A]	0.8	1.3	2.7	4.8
Maximum current [A]	2.4	3.9	8.1	14
Moment of inertia J [$\times 10^{-4}$ kg m ²]	standard	0.088	0.24	0.42
	with electromagnetic brake	0.090	0.31	0.50
Regeneration braking frequency ② ③ [1/min]	4	4	249	140
Recommended load/motor inertia ratio	Less than 15 times the servo motor's inertia moment ⑤			
Speed/position detector	Incremental encoder (resolution servo motor rotation: 131072 p/rev.)			
Structure	Self-cooling (protection rating: IP65) ⑦			
Environment	ambient temperature	Operation: 0–40 °C (no freezing); storage: -15–70 °C (no freezing)		
	ambient humidity	Operation: 80 % RH max. (no condensation); storage: 90 % RH max. (no condensation)		
	atmosphere	Indoors (no direct sunlight); no corrosive gas, no inflammable gas, no oil mist, no dust		
	elevation/vibration ⑧	1000 m or less above sea level: 49 m/s ² , Y: 49 m/s ²		
Weight [kg]	standard motor ⑥	0.6	0.2	1.6
				3.1
Order information	(without brake) Art. no.	239797	253946	253947
				253948

- ① The power facility capacity varies depending on the power supply's impedance.
- ② The regenerative braking frequency shown is the permissible frequency for decelerating a stand-alone motor from rated rpm to a stop. When under load, however, the value becomes the table value divided by (m+1) where m is the load inertia moment divided by the motor inertia moment. When the rated rpm is exceeded, the regenerative brake frequency is inversely proportional to the square of (operating speed/rated speed). When the operating speed varies frequently or when regeneration is constant (as with vertical feeds), find the regeneration heat generated (W) while operating. The heat should not exceed the tolerable regenerative power (W). Refer to the section "OPTIONS AND PERIPHERAL EQUIPMENT" in this catalog for details on the tolerable regenerative power (W). Optimal regenerative resistor varies for each system. Select the most suitable regenerative resistor by using the capacity selection software.
- ③ The regenerative braking frequency of the 600 W or smaller servo amplifier may fluctuate due to the affect of the power voltage since the energy charged by the electrolytic capacitor in the servo amplifier is large.
- ④ There are no limits on regeneration frequency as long as the effective torque is within the rated torque range. However, the load/motor of inertia moment ratio must be more than 15 times.
- ⑤ Contact Mitsubishi Electric if the load/motor of inertia moment ratio exceeds the value in the table.
- ⑥ For servo motors with electromagnetic brake please refer to page 27–28.
- ⑦ The shaft-through portion and connector for cable terminal are excluded.
- ⑧ The vibration direction is shown in the right-side diagram. The numeric value indicates the maximum value of the component (commonly the bracket in the opposite direction of the motor shaft). Fretting of the bearing occurs easily when the motor stops, so maintain vibration of approximately one-half of the allowable value.

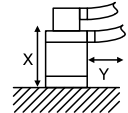

HF-KN Series Servo Motor Torque Characteristics

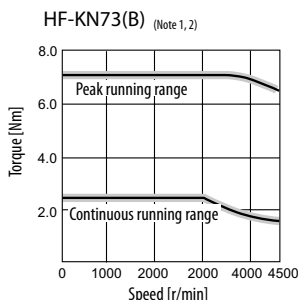
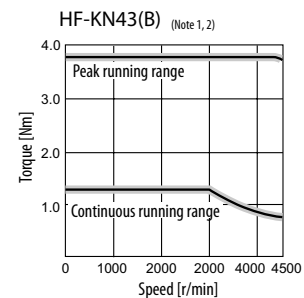
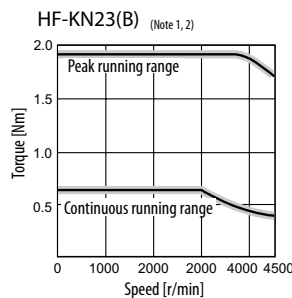
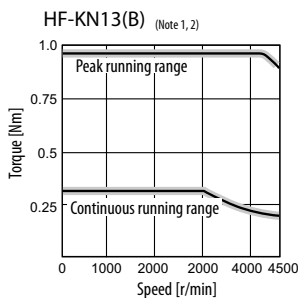

Notes:
 1. : For 3-phase 200 V AC.
 2. : For 1-phase 230 V AC.

HF-SN(B) Series Servo Motor Specifications (200 V Type)

Servo motor model	HF-SN52(B)JK [®]	HF-SN102(B)JK [®]	HF-SN152(B)JK [®]	HF-SN202(B)JK [®]	HF-SN302(B)JK [®]	
Servo amplifier model	MR-JE-70A	MR-JE-100A	MR-JE-200A	MR-JE-200A	MR-JE-300A	
Power facility capacity ^①	[kVA] 1.0	1.7	2.5	3.5	4.8	
Continuous characteristics	rated output [kW]	0.5	1.0	1.5	2.0	3.0
	rated torque [Nm]	2.39	4.77	7.16	9.55	14.3
Maximum torque	[Nm]	7.16	14.3	21.5	28.6	42.9
Rated rotation speed	[rpm]	2000	2000	2000	2000	2000
Maximum rotation speed	[rpm]	3000	3000	3000	3000	2500
Permissible instantaneous rotation speed	[rpm]	3450	3450	3450	3450	2875
Power rate at continuous rated torque	[kW/s]	9.34	19.2	28.8	23.8	35.1
Rated current	[A]	2.9	6.0	8.6	9.0	11
Maximum current	[A]	8.7	18	26	27	33
Moment of inertia J [$\times 10^{-4}$ kg m ²]	standard	6.1	11.9	17.8	38.3	58.5
	with electromagnetic brake	8.3	14.0	20.0	47.9	68.1
Regeneration braking frequency ^{②③}	[1/min]	120	62	152	71	28
Recommended load/motor inertia ratio	Less than 15 times the servo motor's inertia moment ^④					
Speed/position detector	Incremental encoder (resolution servo motor rotation: 131072 p/rev.)					
Structure	Self-cooling (protection rating: IP67) ^⑤					
Environment	ambient temperature	Operation: 0–40 °C (no freezing); storage: -15–70 °C (no freezing)				
	ambient humidity	Operation: 80 % RH max. (no condensation); storage: 90 % RH max. (no condensation)				
	atmosphere	Indoors (no direct sunlight); no corrosive gas, no inflammable gas, no oil mist, no dust				
	elevation/vibration ^⑦	1000 m or less above sea level: X: 24.5 m/s ² , Y: 24.5 m/s ²		1000 m or less above sea level: X: 24.5 m/s ² , Y: 49 m/s ²		
Weight [kg]	standard motor ^⑥	4.8	6.5	8.3	12	15
Order information	(without brake) Art. no.	253952	253953	253954	253965	269030

- ① The power facility capacity varies depending on the power supply's impedance.
- ② The regenerative braking frequency shown is the permissible frequency for decelerating a stand-alone motor from rated rpm to a stop. When under load, however, the value becomes the table value divided by (m+1) where m is the load inertia moment divided by the motor inertia moment. When the rated rpm is exceeded, the regenerative brake frequency is inversely proportional to the square of (operating speed/rated speed). When the operating speed varies frequently or when regeneration is constant (as with vertical feeds), find the regeneration heat generated (W) while operating. The heat should not exceed the tolerable regenerative power (W). Refer to the section "OPTIONS AND PERIPHERAL EQUIPMENT" in this catalog for details on the tolerable regenerative power (W). Optimal regenerative resistor varies for each system. Select the most suitable regenerative resistor by using the capacity selection software.
- ③ The regenerative braking frequency of the 600 W or smaller servo amplifier may fluctuate due to the affect of the power voltage since the energy charged by the electrolytic capacitor in the servo amplifier is large.
- ④ Contact Mitsubishi Electric if the load/motor of inertia moment ratio exceeds the value in the table.
- ⑤ The shaft-through portion is excluded.
- ⑥ For servo motors with electromagnetic brake please refer to page 27–28.
- ⑦ The vibration direction is shown in the right-side diagram. The numeric value indicates the maximum value of the component (commonly the bracket in the opposite direction of the motor shaft). Fretting of the bearing occurs easily when the motor stops, so maintain vibration of approximately one-half of the allowable value.

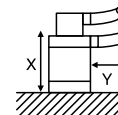

HF-SN Series Servo Motor Torque Characteristics

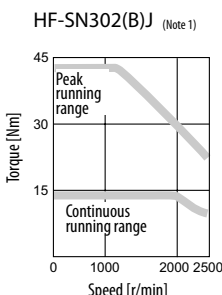
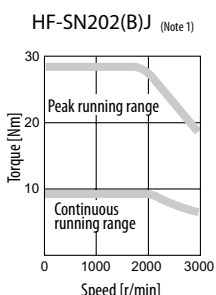
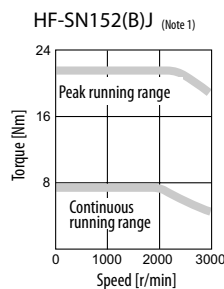
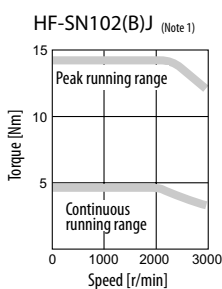
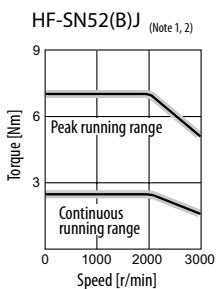

Notes:
 1. —: For 3-phase 200 V AC.
 2. —: For 1-phase 230 V AC.

■ HG-KR(B) Series Servo Motor Specifications (200 V Type)

Servo motor model	HG-KR053(B) ⑥	HG-KR13(B) ⑥	HG-KR23(B) ⑥	HG-KR43(B) ⑥	HG-KR73(B) ⑥
Servo amplifier model	MR-J4-10A/B	MR-J4-10A/B	MR-J4-20A/B	MR-J4-40A/B	MR-J4-70A/B
Power facility capacity ①	[kVA] 0.3	0.3	0.5	0.9	1.3
Continuous characteristics	rated output [kW] 0.05	0.1	0.2	0.4	0.75
	rated torque [Nm] 0.16	0.32	0.64	1.3	2.4
Maximum torque [Nm]	0.56	1.1	2.2	4.5	8.4
Rated rotation speed [rpm]	3000	3000	3000	3000	3000
Maximum rotation speed [rpm]	6000	6000	6000	6000	6000
Permissible instantaneous rotation speed [rpm]	6900	6900	6900	6900	6900
Power rate at continuous rated torque [kW/s]	5.63	13.0	18.3	43.7	45.2
Rated current [A]	0.9	0.8	1.3	2.6	4.8
Maximum current [A]	3.2	2.5	4.6	9.1	17.0
Moment of inertia J [$\times 10^{-4}$ kg m ²] ②	standard 0.0450	0.0777	0.221	0.371	1.26
	with electromagnetic brake 0.0472	0.837	0.243	0.393	1.37
Regeneration braking frequency [1/min]	2 (a)	2 (b)	453	268	393
Recommended load/motor inertia ratio ③	Less than 17 times the servo motor's inertia moment		Less than 26 times the servo motor's inertia moment	Less than 25 times the servo motor's inertia moment	Less than 17 times the servo motor's inertia moment
Speed/position detector	22-bit encoder (resolution per encoder/servo motor rotation: 4194304 p/rev.)				
Structure	Self-cooling (protection rating: IP65) ④				
Environment	ambient temperature	Operation: 0–40 °C (no freezing); storage: –15–70 °C (no freezing)			
	ambient humidity	Operation: 80 % RH max. (no condensation); storage: 90 % RH max. (no condensation)			
	atmosphere	Indoors (no direct sunlight); no corrosive gas, no inflammable gas, no oil mist, no dust			
	elevation/vibration ⑤	1000 m or less above sea level; X: 49 m/s ² , Y: 49 m/s ²			
Weight [kg]	standard motor ⑥ 0.34	0.54	0.91	1.4	2.8
Order information	(without brake) Art. no. 248651	248652	248653	248654	248655

- The power facility capacity varies depending on the power supply's impedance.
- The regenerative braking frequency shown is the permissible frequency for decelerating a stand-alone motor from rated rpm to a stop. When under load, however, the value becomes the table value divided by (m+1) where m is the load inertia moment divided by the motor inertia moment. When the rated rpm is exceeded, the regenerative brake frequency is inversely proportional to the square of (operating speed/rated speed). When the operating speed varies frequently or when regeneration is constant (as with vertical feeds), find the regeneration heat generated (W) while operating. The heat should not exceed the tolerable regenerative power (W). Refer to the section "OPTIONS AND PERIPHERAL EQUIPMENT" in this catalog for details on the tolerable regenerative power (W). Optimal regenerative resistor varies for each system. Select the most suitable regenerative resistor by using the capacity selection software. (a)/(b) When a motor decelerates to a stop from the rated speed, the regenerative frequency will not be limited if the effective torque is within the rated torque range. When a motor decelerates to a stop from the maximum speed, the regenerative frequency will not be limited if the load inertia moment is (a) 26-fold (b) 15-fold or less and the effective torque is within the rated torque range.
- Please contact Mitsubishi Electric if the load/motor of inertia moment ratio exceeds the value in the table
- The shaft-through portion is excluded.
- The vibration direction is shown in the right side diagram. The numeric value indicates the maximum value of the component (commonly the bracket on the antiload side). Fretting of the bearing occurs easily when the motor stops, so please maintain vibration to approximately one-half the allowable value.
- For servo motors with electromagnetic brake please refer to page 27–28.

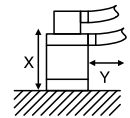

HG-KR Series Servo Motor Torque Characteristics

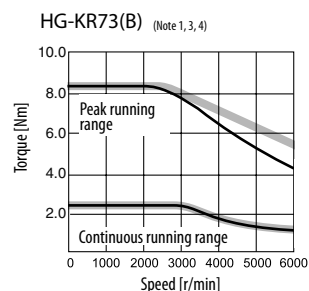
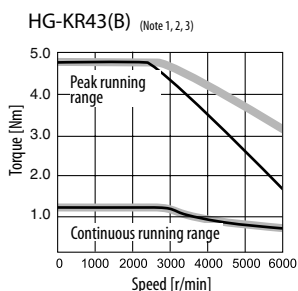
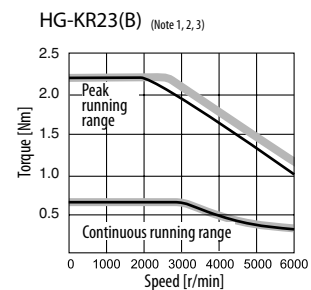
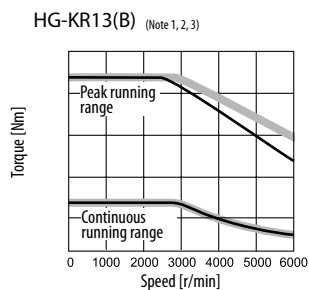
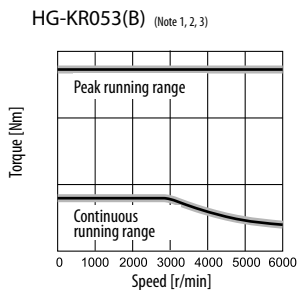

- Notes:
- : For 3-phase 200 V AC or 1-phase 230 V AC.
 - - -: For 1-phase 200 V AC.
 - This line is drawn only where differs from the other two lines.
 - Torque drops when the power supply voltage is below the specified value

HG-MR(B) Series Servo Motor Specifications (200 V Type)

Servo motor model	HG-MR053(B) ①	HG-MR13(B) ①	HG-MR23(B) ①	HG-MR43(B) ①	HG-MR73(B) ①
Servo amplifier model	MR-J4-10A/B	MR-J4-10A/B	MR-J4-20A/B	MR-J4-40A/B	MR-J4-70A/B
Power facility capacity ① [kVA]	0.3	0.3	0.5	0.9	1.3
Continuous characteristics					
rated output [kW]	0.05	0.1	0.2	0.4	0.75
rated torque [Nm]	0.16	0.32	0.64	1.3	2.4
Maximum torque [Nm]	0.48	0.95	1.9	3.8	7.2
Rated rotation speed [rpm]	3000	3000	3000	3000	3000
Maximum rotation speed [rpm]	6000	6000	6000	6000	6000
Permissible instantaneous rotation speed [rpm]	6900	6900	6900	6900	6900
Power rate at continuous rated torque [kW/s]	15.6	33.8	46.9	114.2	97.3
Rated current [A]	1.0	0.9	1.5	2.6	5.8
Maximum current [A]	3.1	2.5	5.3	9.0	20
Moment of inertia J [$\times 10^{-4}$ kg m ²] ②					
standard	0.0162	0.0300	0.0865	0.142	0.586
with electromagnetic brake	0.0224	0.0362	0.109	0.164	0.694
Regeneration braking frequency [1/min]	② (a)	② (b)	1570	920	420
Recommended load/motor inertia ratio	Less than 35 times the servo motors inertia moment ③		Less than 32 times the servo motors inertia moment ③		
Speed/position detector	22-bit encoder (resolution per encoder/servo motor rotation: 4194304 p/rev.				
Structure	Self-cooling (protection rating: IP65) ④				
Environment	ambient temperature: Operation: 0–40 °C (no freezing); storage: –15–70 °C (no freezing)				
	ambient humidity: Operation: 80 % RH max. (no condensation); storage: 90 % RH max. (no condensation)				
	atmosphere: Indoors (no direct sunlight); no corrosive gas, no inflammable gas, no oil mist, no dust				
	elevation/vibration ⑤: 1000 m or less above sea level; X: 49 m/s ² , Y: 49 m/s ²				
Weight [kg] standard motor ⑥	0.34	0.54	0.91	1.4	2.8
Order information (without brake) Art. no.	248661	248662	248663	248664	248665

- ① The power facility capacity varies depending on the power supply's impedance.
- ② The regenerative braking frequency shown is the permissible frequency for decelerating a stand-alone motor from rated rpm to a stop. When under load, however, the value becomes the table value divided by (m+1) where m is the load inertia moment divided by the motor inertia moment. When the rated rpm is exceeded, the regenerative brake frequency is inversely proportional to the square of (operating speed/rated speed). When the operating speed varies frequently or when regeneration is constant (as with vertical feeds), find the regeneration heat generated (W) while operating. The heat should not exceed the tolerable regenerative power (W). Refer to the section "OPTIONS AND PERIPHERAL EQUIPMENT" in this catalog for details on the tolerable regenerative power (W). Optimal regenerative resistor varies for each system. Select the most suitable regenerative resistor by using the capacity selection software.
(a)/(b) When a motor decelerates to a stop from the rated speed, the regenerative frequency will not be limited if the effective torque is within the rated torque range. When a motor decelerates to a stop from the maximum speed, the regenerative frequency will not be limited if the load inertia moment is (a) 26-fold (b) 15-fold or less and the effective torque is within the rated torque range.
- ③ Please contact Mitsubishi Electric if the load/motor of inertia moment ratio exceeds the value in the table
- ④ The shaft-through portion is excluded.
- ⑤ The vibration direction is shown in the right side diagram. The numeric value indicates the maximum value of the component (commonly the bracket on the antiload side). Fretting of the bearing occurs easily when the motor stops, so please maintain vibration to approximately one-half the allowable value.
- ⑥ For servo motors with electromagnetic brake please refer to page 27–28..

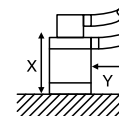

HG-MR Series Servo Motor Torque Characteristics

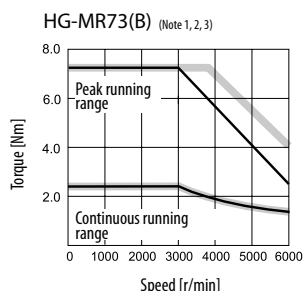
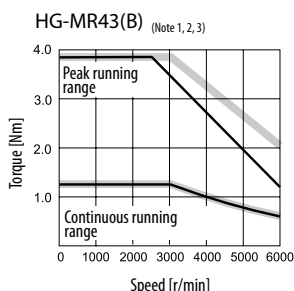
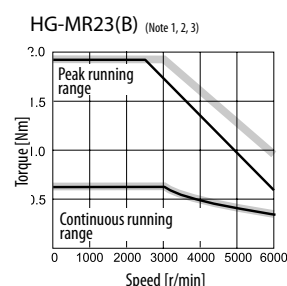
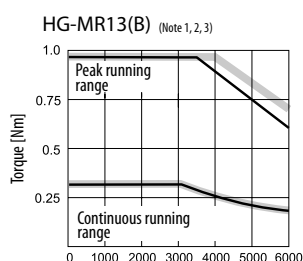
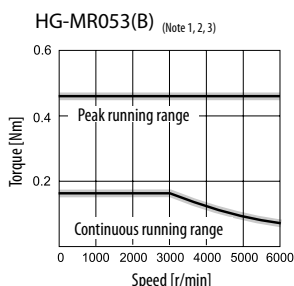

- Notes:
- 1. —: For 3-phase 200 V AC or 1-phase 230 V AC.
 - 2. —: For 1-phase 200 V AC.
 - 3. This line is drawn only where differs from the other two lines.
Torque drops when the power supply voltage is below the specified value

■ HG-RR(B) Series Servo Motor Specifications (200 V Type)

Servo motor model	HG-RR103(B) ①	HG-RR153(B) ①	HG-RR203(B) ①	HG-RR353(B) ①	HG-RR503(B) ①
Servo amplifier model	MR-J4-200A/B	MR-J4-200A/B	MR-J4-350A/B	MR-J4-500A/B	MR-J4-500A/B
Power facility capacity ①	[kVA] 1.7	2.5	3.5	5.5	7.5
Continuous characteristics	rated output [kW] 1.0	1.5	2.0	3.5	5.0
	rated torque [Nm] 3.2	4.8	6.4	11.1	15.9
Maximum torque [Nm] 8.0	11.9	15.9	27.9	39.8	
Rated rotation speed [rpm] 3000	3000	3000	3000	3000	3000
Maximum rotation speed [rpm] 4500	4500	4500	4500	4500	4500
Permissible instantaneous rotation speed [rpm] 5175	5175	5175	5175	5175	5175
Power rate at continuous rated torque [kW/s] 67.4	120	176	150	211	
Rated current [A] 6.1	8.8	14	23	28	
Maximum current [A] 18	23	37	58	70	
Regeneration braking frequency ② [1/min] 1090	860	710	174	125	
Moment of inertia J [$\times 10^{-4}$ kg m ²] ② 1.5	1.9	2.3	8.3	12	
Recommended load/motor inertia ratio	Less than 5 times the servo motors inertia moment ③				
Speed/position detector	Resolution per encoder/servo motor rotation: 4194304 p/rev (22-bit)				
Structure	Self-cooling (protection rating: IP65) ④				
Environment	ambient temperature	Operation: 0–40 °C (no freezing); storage: -15–70 °C (no freezing)			
	ambient humidity	Operation: 80 % RH max. (no condensation); storage: 90 % RH max. (no condensation)			
	atmosphere	Indoors (no direct sunlight); no corrosive gas, no inflammable gas, no oil mist, no dust			
	elevation/vibration ⑤ ③	1000 m or less above sea level; X: 24.5 m/s ² ; Y: 24.5 m/s ²			
Weight [kg] standard motor ⑥	3.9	5.0	6.2	12	17
Order information	(without brake) Art.no. 262896	262897	262898	262899	262900

- ① The power facility capacity varies depending on the power supply's impedance.
- ② The regenerative braking frequency shown is the permissible frequency for decelerating a stand-alone motor from rated rpm to a stop. When under load, however, the value becomes the table value divided by (m+1) where m is the load inertia moment divided by the motor inertia moment. When the rated rpm is exceeded, the regenerative brake frequency is inversely proportional to the square of (operating speed/rated speed). When the operating speed varies frequently or when regeneration is constant (as with vertical feeds), find the regeneration heat generated (W) while operating. The heat should not exceed the tolerable regenerative power (W). Refer to the section "OPTIONS AND PERIPHERAL EQUIPMENT" in this catalog for details on the tolerable regenerative power (W). Optimal regenerative resistor varies for each system. Select the most suitable regenerative resistor by using the capacity selection software.
- ③ Please contact Mitsubishi Electric if the load/motor of inertia moment ratio exceeds the value in the table.
- ④ The shaft-through portion is excluded.
- ⑤ The vibration direction is shown in the right side diagram. The numeric value indicates the maximum value of the component (commonly the bracket on the antiload side). Fretting of the bearing occurs easily when the motor stops, so please maintain vibration to approximately one-half the allowable value.
- ⑥ For servo motors with electromagnetic brake please refer to page 27–28.

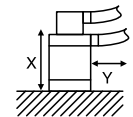

HG-RR Series Servo Motor Torque Characteristics

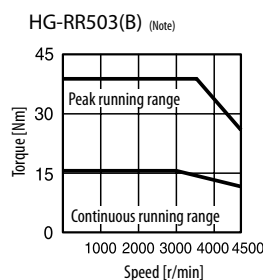
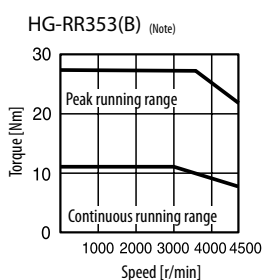
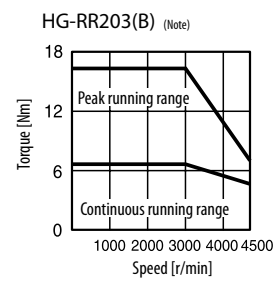
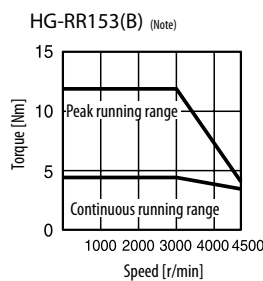
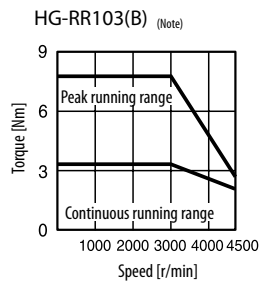

Note: — : For 3-phase 200 V AC.

■ HG-SR(B) Series Servo Motor Specifications (200 V Type)

Servo motor model	HG-SR52(B) ①	HG-SR102(B) ①	HG-SR152(B) ①	HG-SR202(B) ①	HG-SR352(B) ①	HG-SR502(B) ①	HG-SR702(B) ①
Servo amplifier model	MR-J4-60A/B	MR-J4-100A/B	MR-J4-200A/B	MR-J4-200A/B	MR-J4-350A/B	MR-J4-500A/B	MR-J4-700A/B
Power facility capacity ①	[kVA] 1.0	1.7	2.5	3.5	5.5	7.5	10
Continuous characteristics	rated output [kW]	0.5	1.0	1.5	2.0	3.5	7.0
	rated torque [Nm]	2.4	4.8	7.2	9.5	16.7	33.4
Maximum torque	[Nm]	7.2	14.3	21.5	28.6	50.1	100
Rated rotation speed	[rpm]	2000	2000	2000	2000	2000	2000
Maximum rotation speed	[rpm]	3000	3000	3000	3000	3000	3000
Permissible instantaneous rotation speed	[rpm]	3450	3450	3450	3450	3450	3450
Power rate at continuous rated torque	[kW/s]	7.85	10.7	32.1	19.5	35.5	57.2
Rated current	[A]	2.9	5.6	9.4	9.6	14	22
Maximum current	[A]	9.0	17	29	31	45	83
Moment of inertia J [$\times 10^{-4}$ kg m ²] ②	standard	7.26	11.6	16	46.8	78.6	99.7
	with electromagnetic brake	9.48	13.8	18.2	56.5	88.2	109
Regeneration braking frequency	[1/min]	31	38	139	47	28	29
Recommended load/ motor inertia ratio	Less than 15 times the servo motors inertia moment ③		Less than 17 times the servo motors inertia moment ③		Less than 15 times the servo motors inertia moment ③		
Speed/position detector	22-bit encoder (resolution per encoder/servo motor rotation: 4194304 p/rev.						
Structure	Self-cooling (protection rating: IP67) ④						
Environment	ambient temperature	Operation: 0–40 °C (no freezing); storage: -15–70 °C (no freezing)					
	ambient humidity	Operation: 80 % RH max. (no condensation); storage: 90 % RH max. (no condensation)					
	atmosphere	Indoors (no direct sunlight); no corrosive gas, no inflammable gas, no oil mist, no dust					
	elevation/vibration ⑤	1000 m or less above sea level; X: 24.5 m/s ² , Y: 24.5 m/s ²		1000 m or less above sea level; X: 24.5 m/s ² , Y: 49 m/s ²		1000 m or less above sea level; X: 24.5 m/s ² , Y: 29.4 m/s ²	
Weight [kg]	standard motor ⑥	4.8	6.2	7.3	11	16	20
Order information	(without brake) Art. no.	248671	248672	248673	248674	248675	242676

- ① The power facility capacity varies depending on the power supply's impedance.
- ② The regenerative braking frequency shown is the permissible frequency for decelerating a stand-alone motor from rated rpm to a stop. When under load, however, the value becomes the table value divided by (m+1) where m is the load inertia moment divided by the motor inertia moment. When the rated rpm is exceeded, the regenerative brake frequency is inversely proportional to the square of (operating speed/rated speed). When the operating speed varies frequently or when regeneration is constant (as with vertical feeds), find the regeneration heat generated (W) while operating. The heat should not exceed the tolerable regenerative power (W). Refer to the section "OPTIONS AND PERIPHERAL EQUIPMENT" in this catalog for details on the tolerable regenerative power (W). Optimal regenerative resistor varies for each system. Select the most suitable regenerative resistor by using the capacity selection software.
- ③ Please contact Mitsubishi Electric if the load/motor of inertia moment ratio exceeds the value in the table
- ④ The shaft-through portion is excluded.
- ⑤ The vibration direction is shown in the right side diagram. The numeric value indicates the maximum value of the component (commonly the bracket on the antiload side). Fretting of the bearing occurs easily when the motor stops, so please maintain vibration to approximately one-half the allowable value.
- ⑥ For servo motors with electromagnetic brake please refer to page 27–28.

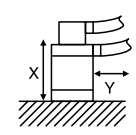

HG-SR Series Servo Motor Torque Characteristics

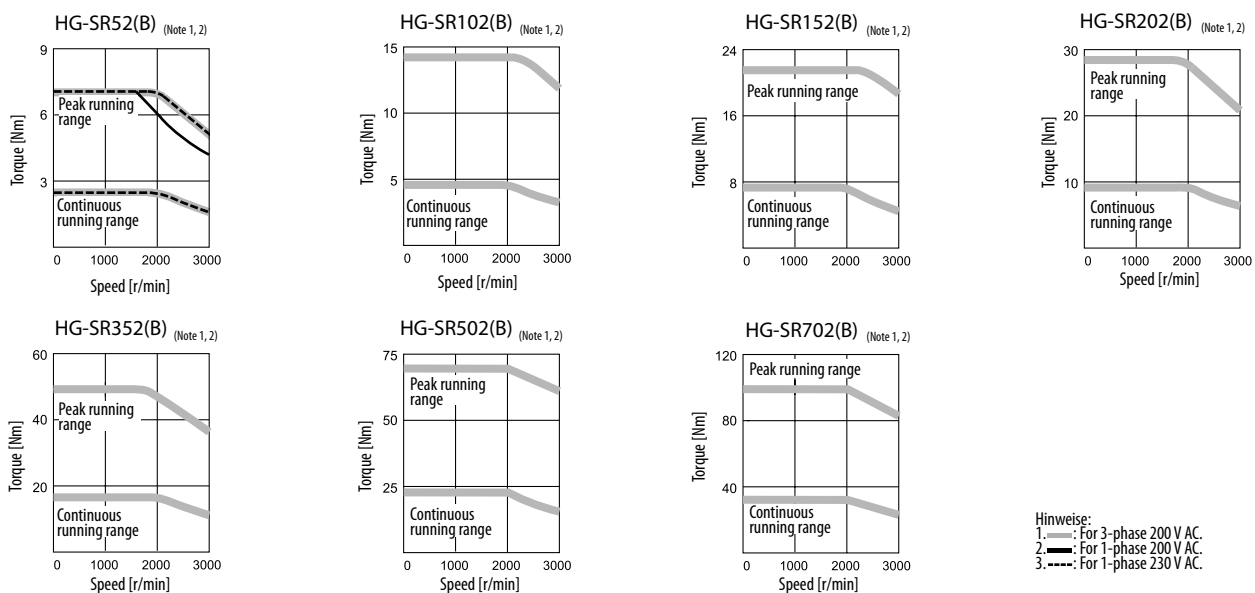

■ HG-SR(B) Series Servo Motor Specifications (400 V Type)

Servo motor model	HG-SR524(B) ①	HG-SR1024(B) ①	HG-SR1524(B) ①	HG-SR2024(B) ①	HG-SR3524(B) ①	HG-SR5024(B) ①	HG-SR7024(B) ①
Servo amplifier model	MR-J4-60A4/B4	MR-J4-100A4/B4	MR-J4-200A4/B4	MR-J4-200A4/B4	MR-J4-350A4/B4	MR-J4-500A4/B4	MR-J4-700A4/B4
Power facility capacity ①	[kVA] 1.0	1.7	2.5	3.5	5.5	7.5	10
Continuous rated output	[kW] 0.5	1.0	1.5	2.0	3.5	5.0	7.0
Characteristics rated torque	[Nm] 2.4	4.8	7.2	9.5	16.7	23.9	33.4
Maximum torque	[Nm] 7.2	14.3	21.5	28.6	50.1	71.6	100
Rated rotation speed	[rpm] 2000	2000	2000	2000	2000	2000	2000
Maximum rotation speed	[rpm] 3000	3000	3000	3000	3000	3000	3000
Permissible instantaneous rotation speed	[rpm] 3450	3450	3450	3450	3450	3450	3450
Power rate at continuous rated torque	[kW/s] 7.85	19.7	32.1	19.5	35.5	57.2	74.0
Rated current	[A] 1.5	2.8	4.7	4.9	7.0	11	13
Maximum current	[A] 4.5	8.9	17	17	27	42	59
Moment of inertia standard	7.26	11.6	16.0	46.8	78.6	99.7	151
J [$\times 10^{-4}$ kg m ²] ② with electromagnetic brake	9.48	13.8	18.2	56.5	88.2	109	161
Regeneration braking frequency	[1/min] 46	29	139	47	34	29	25
Recommended load/ motor inertia ratio	Less than 15 times the servo motors inertia moment ③		Less than 17 times the servo motors inertia moment ③		Less than 15 times the servo motors inertia moment ③		
Speed/position detector	22-bit encoder (resolution per encoder/servo motor rotation: 4194304 p/rev.)						
Structure	Self-cooling (protection rating: IP67) ④						
Environment	ambient temperature						
	Operation: 0–40 °C (no freezing); Storage: -15–70 °C (no freezing)						
	ambient humidity						
	Operation: 80 % RH max. (no condensation); Storage: 90 % RH max. (no condensation)						
atmosphere							
Indoors (no direct sunlight); no corrosive gas, no inflammable gas, no oil mist, no dust							
elevation/vibration ⑤							
1000 m or less above sea level; X: 24.5 m/s ² , Y: 24.5 m/s ²			1000 m or less above sea level; X: 24.5 m/s ² , Y: 49 m/s ²		1000 m or less above sea level; X: 24.5 m/s ² , Y: 29.4 m/s ²		
Weight [kg] standard motor ⑥	4.8	6.2	7.3	11	16	20	27
Order information (without brake) Art. no.	261431	261432	261433	261434	261435	261436	261437

- ① The power facility capacity varies depending on the power supply's impedance.
- ② The regenerative braking frequency shown is the permissible frequency for decelerating a stand-alone motor from rated rpm to a stop. When under load, however, the value becomes the table value divided by (m+1) where m is the load inertia moment divided by the motor inertia moment. When the rated rpm is exceeded, the regenerative brake frequency is inversely proportional to the square of (operating speed/rated speed). When the operating speed varies frequently or when regeneration is constant (as with vertical feeds), find the regeneration heat generated (W) while operating. The heat should not exceed the tolerable regenerative power (W). Refer to the section "OPTIONS AND PERIPHERAL EQUIPMENT" in this catalog for details on the tolerable regenerative power (W). Optimal regenerative resistor varies for each system. Select the most suitable regenerative resistor by using the capacity selection software.
- ③ Please contact Mitsubishi Electric if the load/motor of inertia moment ratio exceeds the value in the table
- ④ The shaft-through portion is excluded.
- ⑤ The vibration direction is shown in the right side diagram. The numeric value indicates the maximum value of the component (commonly the bracket on the antiload side). Fretting of the bearing occurs easily when the motor stops, so please maintain vibration to approximately one-half the allowable value.
- ⑥ For servo motors with electromagnetic brake please refer to page 27–28.

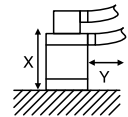

HG-SR Series Servo Motor Torque Characteristics

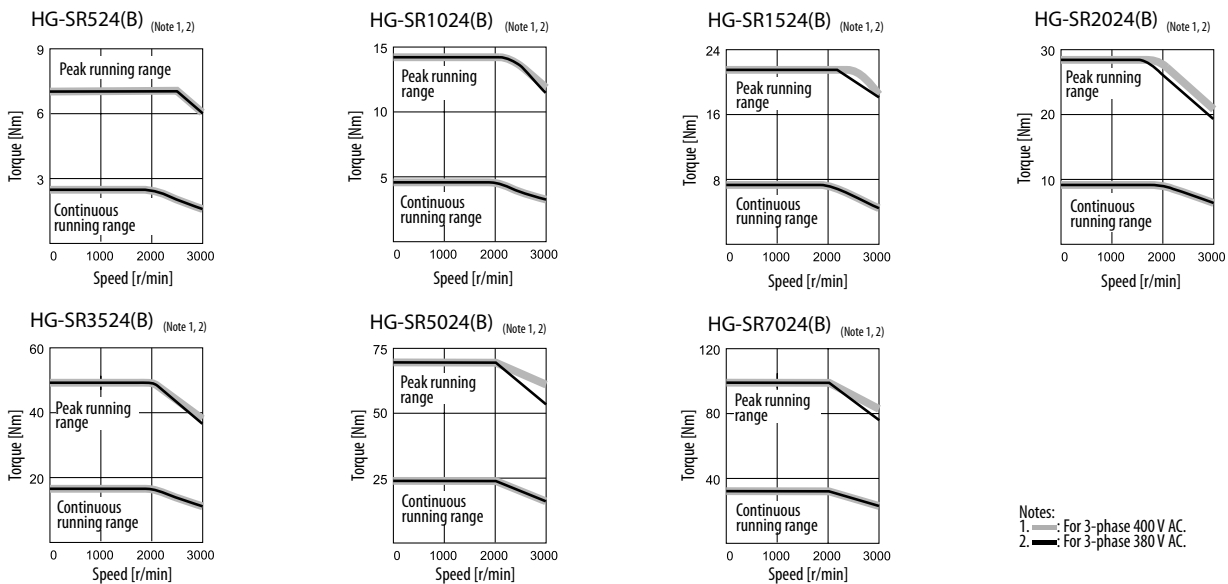

HG-JR(B) Series Servo Motor Specifications (200 V Type)

Servo motor model	HG-JR 53(B) ⑥	HG-JR 73(B) ⑥	HG-JR 103(B) ⑥	HG-JR 153(B) ⑥	HG-JR 203(B) ⑥	HG-JR 353(B) ⑥	HG-JR 503(B) ⑥	HG-JR 703(B) ⑥	HG-JR 903(B) ⑥	HG-JR 11K1M(B) ⑥	HG-JR 15K1M(B) ⑥	HG-JR 22K1M ⑥	
Servo amplifier model ①	MR-J4□A/B												
Power facility capacity ①	[kVA]												
Continuous characteristics ⑦	rated output	[kW]											
	rated torque	[Nm]											
Maximum torque ②	[Nm]												
Rated rotation speed	[U/min]												
Maximum rotation speed	[U/min]												
Permissible instantaneous rotation speed	[U/min]												
Power rate at continuous rated torque	[kW/s]												
Rated current ②	[A]												
Maximum current	[A]												
Moment of inertia J [$\times 10^{-4}$ kg m ²]	standard												
	with electromagnetic brake												
Regeneration braking frequency ② ⑦	[1/min]												
Recommended load/motor inertia ratio	Less than 10 times the servo motor's inertia moment ③												
Speed/position detector	22-bit encoder (resolution per encoder/servo motor rotation: 4194304 p/rev.)												
Structure	Self-cooling (protection rating: IP67) ④											Fan-cooling (protection rating: IP44) ④	
Environment	ambient temperature	Operation: 0–40 °C (no freezing); storage: –15–70 °C (no freezing)											
	ambient humidity	Operation: 80 % RH max. (no condensation); storage: 90 % RH max. (no condensation)											
	atmosphere	Indoors (no direct sunlight); no corrosive gas, no inflammable gas, no oil mist, no dust											
elevation/vibration ⑤	1000 m or less above sea level; X: 24.5 m/s ² , Y: 24.5 m/s ²						1000 m or less above sea level; X: 24.5 m/s ² , Y: 29.4 m/s ²			1000 m or less above sea level; X: 24.5 m/s ² , Y: 24.5 m/s ²			
	Weight [kg] standard motor ⑥	3.0	3.7	4.5	5.9	7.5	13	18	29	36	62	86	120
Order information (without brake) Art. no.	261539	261540	261541	261542	261543	261544	261545	261546 8	261547 8	261557	261558	261559	

- ① The power facility capacity varies depending on the power supply's impedance.
- ② The regenerative braking frequency shown is the permissible frequency for decelerating a stand-alone motor from rated rpm to a stop. When under load, however, the value becomes the table value divided by (m+1) where m is the load inertia moment divided by the motor inertia moment. When the rated rpm is exceeded, the regenerative brake frequency is inversely proportional to the square of (operating speed/rated speed). When the operating speed varies frequently or when regeneration is constant (as with vertical feeds), find the regeneration heat generated (W) while operating. The heat should not exceed the tolerable regenerative power (W). Refer to the section "OPTIONS AND PERIPHERAL EQUIPMENT" in this catalog for details on the tolerable regenerative power (W). Optimal regenerative resistor varies for each system. Select the most suitable regenerative resistor by using the capacity selection software.
- ③ Please contact Mitsubishi Electric if the load/motor of inertia moment ratio exceeds the value in the table.
- ④ The shaft-through portion is excluded.
- ⑤ The vibration direction is shown in the right side diagram. The numeric value indicates the maximum value of the component (commonly the bracket on the antiload side). Fretting of the bearing occurs easily when the motor stops, so please maintain vibration to approximately one-half the allowable value.
- ⑥ For servo motors with electromagnetic brake please refer to page 27–28.
- ⑦ The maximum torque of the HG-JR534(B)–HG-JR5034(B) motors can be increased from 300 % to 400 % by increasing the amplifier capacity by one rank.
- ⑧ The item has longer delivery time. Please contact your Mitsubishi Electric representative.

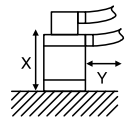

HG-JR Series Servo Motor Torque Characteristics

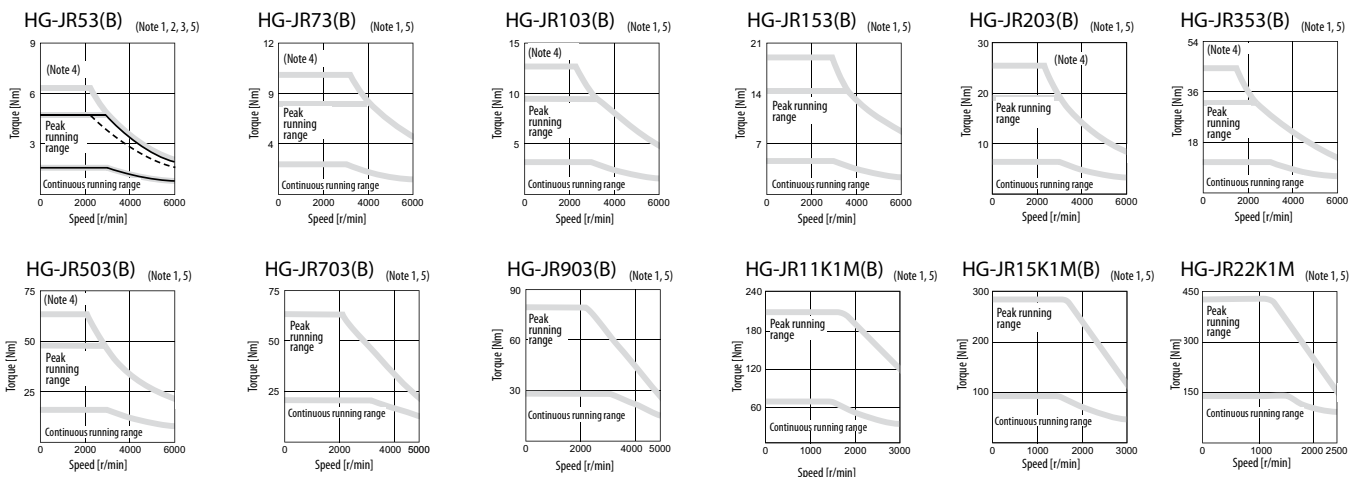

- 1 —: For 3-phase 200 V AC.
- 2 —: For 1-phase 200 V AC.
- 3 - - -: For 1-phase 230 V AC.
- 4. This value is applicable when the torque is maximally increased. Refer to "Combinations of HG-JR Servo Motor Series and Servo Amplifier (200 V Class) for Increasing the Maximum Torque to 400 % of the Rated Torque.
- 5. Torque drops when the power supply voltage is below the specified value.

■ HG-JR(B) Series Servo Motor Specifications (400 V Type)

Servo motor model	HG-JR 534(B) ⑥	HG-JR 734(B) ⑥	HG-JR 1034(B) ⑥	HG-JR 1534(B) ⑥	HG-JR 2034(B) ⑥	HG-JR 3534(B) ⑥	HG-JR 5034(B) ⑥	HG-JR 7034(B) ⑥	HG-JR 9034(B) ⑥	HG-JR 11K1M4(B) ⑥	HG-JR 15K1M4(B) ⑥	HG-JR 22K1M4 ⑥		
Servo amplifier model	MR-J4□A4/B4													
Power facility capacity ①	[kVA]	1.0	1.3	1.7	2.5	3.5	5.5	7.5	10	13	16	22	33	
Continuous characteristics ②	rated output	[kW]	0.5	0.75	1.0	1.5	2.0	3.3	5.0	7.0	9.0	11	22	
	rated torque	[Nm]	1.6	2.4	3.2	4.8	6.4	10.5	15.9	22.3	28.6	70	95.5	140
Maximum torque ②	[Nm]	4.8	7.2	9.6	14.3	19.1	32.0	47.7	66.8	85.8	210	286	420	
Rated rotation speed	[U/min]	3000	3000	3000	3000	3000	3000	3000	3000	3000	1500	1500	1500	
Maximum rotation speed	[U/min]	6000	6000	6000	6000	6000	6000	6000	5000	5000	3000	3000	2500	
Permissible instantaneous rotation speed	[U/min]	6900	6900	6900	6900	6900	6900	6900	5750	5750	3450	3450	2875	
Power rate at continuous rated torque	[kW/s]	16.7	27.3	38.2	60.2	82.4	83.5	133	115	147	223	290	401	
Rated current ②	[A]	1.5	2.8	2.8	5.4	5.4	8.3	14	17	21	31	38	50	
Maximum current	[A]	4.5	8.4	8.4	17	17	26	41	52	67	100	123	170	
Moment of inertia J [$\times 10^{-4}$ kg m ²]	standard	1.52	2.09	2.65	3.79	4.92	13.2	19.0	43.3	55.8	220	315	489	
	with electromagnetic brake	2.02	2.59	3.15	4.29	5.42	15.4	21.2	52.9	65.4	240	336	—	
Regeneration braking frequency ② ⑦	[1/min]	99	72	53	265	203	75	68	56	205	143	162	104	
Recommended load/motor inertia ratio	Less than 10 times the servo motor's inertia moment ③													
Speed/position detector	22-bit encoder (resolution per encoder/servo motor rotation: 4194304 p/rev.)													
Structure	Self-cooling (protection rating: IP67) ④											Fan-cooling (protection rating: IP44) ④		
Environment	ambient temperature	Operation: 0–40 °C (no freezing); storage: -15–70 °C (no freezing)												
	ambient humidity	Operation: 80 % RH max. (no condensation); storage: 90 % RH max. (no condensation)												
	atmosphere	Indoors (no direct sunlight); no corrosive gas, no inflammable gas, no oil mist, no dust												
elevation/vibration ⑤	1000 m or less above sea level; X: 24.5 m/s ² , Y: 24.5 m/s ²								1000 m or less above sea level; X: 24.5 m/s ² , Y: 29.4 m/s ²		1000 m or less above sea level; X: 24.5 m/s ² , Y: 24.5 m/s ²			
	Weight [kg]	standard motor ⑥	3.0	3.7	4.5	5.9	7.5	13	18	29	36	62	86	120
Order information	(without brake)	Art. no.	261445	261446	261447	261448	261449	261450	261451	261452 ⑧	261453 ⑧	261384	261535	261536

- ① The power facility capacity varies depending on the power supply's impedance.
- ② The regenerative braking frequency shown is the permissible frequency for decelerating a stand-alone motor from rated rpm to a stop. When under load, however, the value becomes the table value divided by (m+1) where m is the load inertia moment divided by the motor inertia moment. When the rated rpm is exceeded, the regenerative brake frequency is inversely proportional to the square of (operating speed/rated speed). When the operating speed varies frequently or when regeneration is constant (as with vertical feeds), find the regeneration heat generated (W) while operating. The heat should not exceed the tolerable regenerative power (W). Refer to the section "OPTIONS AND PERIPHERAL EQUIPMENT" in this catalog for details on the tolerable regenerative power (W). Optimal regenerative resistor varies for each system. Select the most suitable regenerative resistor by using the capacity selection software.
- ③ Please contact Mitsubishi Electric if the load/motor of inertia moment ratio exceeds the value in the table.
- ④ The shaft-through portion is excluded.
- ⑤ The vibration direction is shown in the right side diagram. The numeric value indicates the maximum value of the component (commonly the bracket on the antiload side). Fretting of the bearing occurs easily when the motor stops, so please maintain vibration to approximately one-half the allowable value.
- ⑥ For servo motors with electromagnetic brake please refer to page 27–28.
- ⑦ The maximum torque of the HG-JR534(B)–HG-JR5034(B) motors can be increased from 300 % to 400 % by increasing the amplifier capacity by one rank.
- ⑧ The item has longer delivery time. Please contact your Mitsubishi Electric representative.

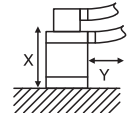

HG-JR Series Servo Motor Torque Characteristics

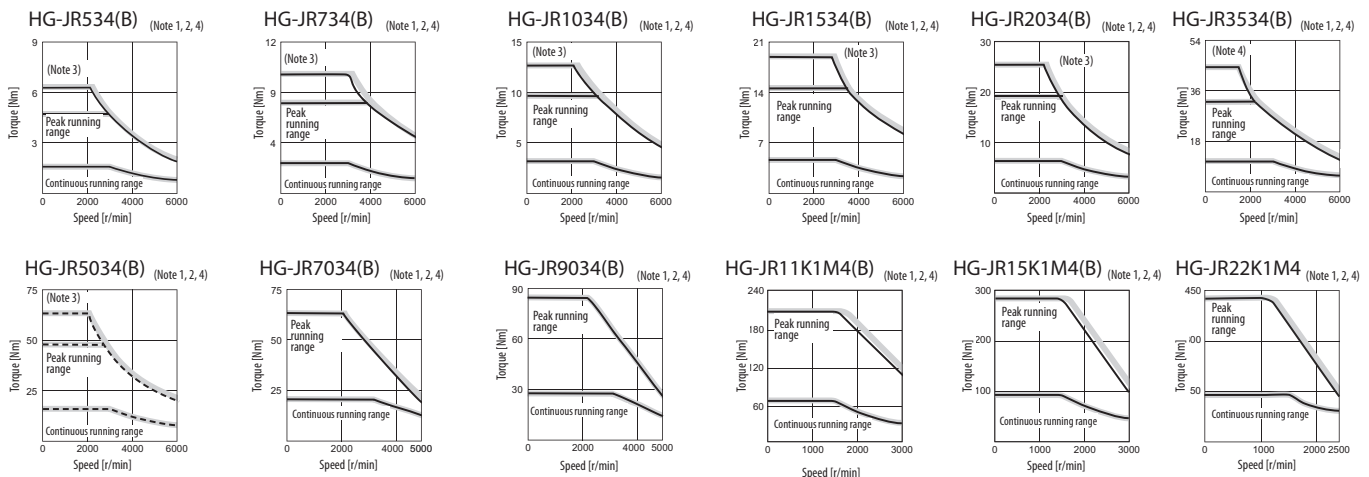

- Notes:
1. —: For 3-phase 400 V AC.
 2. —: For 3-phase 380 V AC.
 3. This value is applicable when the torque is maximally increased. Refer to "Combinations of HG-JR Servo Motor Series and Servo Amplifier (200 V Class) for Increasing the Maximum Torque to 400 % of the Rated Torque."
 4. Torque drops when the power supply voltage is below the specified value.

Servo Motor with Electromagnetic Brake

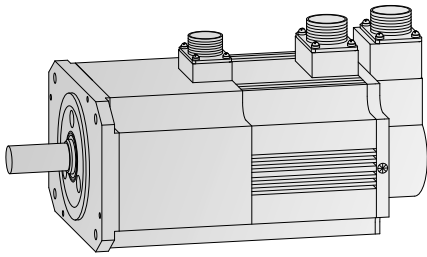

For applications requiring the motor shaft to be held in position (e.g. vertical lift applications), all offered motors are available with an electro-

magnetic brake. The wide variety of servo motors allows the user to choose a motor, which suits best according to the task.

Motor model (200 V)	HF-KN				HF-SN					
	13B	23KB	43KB	73BJK	52BJK	102BJK	152BJK	202BJK	302BJK	
Type	Spring-loaded safety brake				Spring-loaded safety brake					
Rated voltage	24 V DC				24 V DC					
Static friction torque [Nm]	0.32	1.3	1.3	2.4	8.5	8.5	8.5	44	44	
Rated current at 20 °C [A]	0.26	0.33	0.33	0.42	0.8	0.8	0.8	1.4	1.4	
Coil resistance at 20 °C [Ω]	91	73	73	57	29	29	29	16.8	16.8	
Power consumption at 20 °C [W]	6.3	7.9	7.9	10	20	20	20	34	34	
Moment of inertia J ^② [10 ⁻⁴ kg m ²]	0.090	0.31	0.50	1.63	8.3	14	20	47.9	68.1	
Permissible braking volume [J]/time	5.6	22	22	64	400	400	400	4500	4500	
[J]/hour	56	220	220	640	4000	4000	4000	45000	45000	
Brake life [times] ^③	20000				20000					
Brake volume per brake action [J]	5.6	22	22	64	200	200	200	1000	1000	
Weight ^① [kg]	0.8	1.6	2.0	4.1	6.7	8.5	11.0	18.0	21	
Order information	Art. no.	239801	253949	253950	253951	253966	253967	253968	253969	269031

① Total mass of motor with electromagnetic brake ② Total moment of inertia of motor with electromagnetic brake ③ Brake gap cannot be adjusted.

Motor model (200 V)	HG-KR					HG-MR					HG-RR					
	053B	13B	23B	43B	73B	103B	153B	203B	353B	503B	52B	102B	152B	202B	352B	
Type	Spring-loaded safety brake					Spring-loaded safety brake					Spring-loaded safety brake					
Rated voltage	24 V DC					24 V DC					24 V DC					
Static friction torque [Nm]	0.32	0.32	1.3	1.3	2.4	0.32	0.32	1.3	1.3	2.4	7.0	7.0	7.0	17	17	
Rated current at 20 °C [A]	0.26	0.26	0.33	0.33	0.42	0.8	0.8	0.8	0.96	0.96	0.8	0.8	0.8	1.4	1.4	
Coil resistance at 20 °C [Ω]	91	91	73	73	57	30	30	30	25	25	19	19	19	23	23	
Power consumption at 20 °C [W]	6.3	6.3	7.9	7.9	10	6.3	6.3	7.9	7.9	10	19	19	19	23	23	
Moment of inertia J ^② [10 ⁻⁴ kg m ²]	0.0452	0.837	0.243	0.393	1.37	0.0224	0.0362	0.109	0.164	0.694	1.58	2.25	2.65	11.8	15.5	
Permissible braking volume [J]/time	5.6	5.6	22	22	64	5.6	5.6	22	22	64	400	400	400	400	400	
[J]/hour	56	56	220	220	640	56	56	220	220	640	4000	4000	4000	4000	4000	
Brake life [times] ^③	20000					20000					20000					
Brake volume per brake action [J]	5.6	5.6	22	22	64	5.6	5.6	22	22	64	200	200	200	200	200	
Weight ^① [kg]	0.54	0.74	1.3	1.8	3.8	0.54	0.74	1.3	1.8	3.8	6	7	8.3	15	21	
Order information	Art. no.	248656	248657	248658	248659	248660	248666	248667	248668	248669	248670	262901	262902	262903	262904	262905

① Total mass of motor with electromagnetic brake ② Total moment of inertia of motor with electromagnetic brake ③ Brake gap cannot be adjusted.

Motor model (400 V)	HG-SR (200)							HG-SR (400)							
	52B	102B	152B	202B	352B	502B	702B	524B	1024B	1524B	2024B	3524B	5024B	7024B	
Type	Spring-loaded safety brake							Spring-loaded safety brake							
Rated voltage	24 V DC							24 V DC							
Static friction torque [Nm]	8.5	8.5	8.5	44	44	44	44	8.5	8.5	8.5	44	44	44	44	
Rated current at 20 °C [A]	0.8	0.8	0.8	1.4	1.4	1.4	1.4	0.8	0.8	0.8	1.4	1.4	1.4	1.4	
Coil resistance at 20 °C [Ω]	29	29	29	16.8	16.8	16.8	16.8	29	29	29	16.8	16.8	16.8	16.8	
Power consumption at 20 °C [W]	20	20	20	34	34	34	34	20	20	20	34	34	34	34	
Moment of inertia J ^② [$\times 10^{-4}$ kg m ²]	9.48	13.8	18.2	56.5	88.2	109	161	9.48	13.8	18.2	56.5	88.2	109	161	
Permissible braking volume [J]/time	400	400	400	4500	4500	4500	4500	400	400	400	4500	4500	4500	4500	
[J]/hour	4000	4000	4000	45000	45000	45000	45000	4000	4000	4000	45000	45000	45000	45000	
Brake life [times] ^③	20000							20000							
Brake volume per brake action [J]	200	200	200	1000	1000	1000	1000	200	200	200	1000	1000	1000	1000	
Weight ^① [kg]	6.7	8.2	9.3	17	22	26	33	6.7	8.2	9.3	17	22	26	33	
Order information	Art. no.	248678	248679	248680	248681	248682	248683	248684	261438	261439	261440	261441	261442	261443	261444

① Total mass of motor with electromagnetic brake ② Total moment of inertia of motor with electromagnetic brake ③ Brake gap cannot be adjusted.
 ④ The item has longer delivery time. Please contact your Mitsubishi Electric representative.

Motor model (400 V)	HG-JR (200)											
	53B	73B	103B	153B	203B	353B	503B	703B	903B	11K1MB	15K1MB	
Type	Spring-loaded safety brake											
Rated voltage	24 V DC											
Static friction torque [Nm]	6.6	6.6	6.6	6.6	6.6	16	16	44	44	126	126	
Rated current at 20 °C [A]	0.5	0.5	0.5	0.5	0.5	1.0	1.0	1.4	1.4	1.3	1.3	
Coil resistance at 20 °C [Ω]	49	49	49	49	49	25	25	16.8	16.8	18	18	
Leistungsaufnahme bei 20 °C [W]	11.7	11.7	11.7	11.7	11.7	23	23	34	34	32	32	
Moment of inertia J ^② [$\times 10^{-4}$ kg m ²]	2.02	2.59	3.15	4.29	5.42	15.4	21.2	52.9	65.4	240	336	
Permissible braking volume [J]/time	64	64	64	64	64	400	400	4500	4500	5000	5000	
[J]/hour	640	640	640	640	640	4000	4000	45000	45000	45200	45200	
Brake life [times] ^③	5000	5000	5000	5000	5000	5000	5000	20000	20000	20000	20000	
Brake volume per brake action [J]	64	64	64	64	64	400	400	1000	1000	400	400	
Weight ^① [kg]	4.4	5.1	5.9	7.3	8.9	15	20	35	42	74	97	
Order information	Art. no.	261548	261549	261550	261551	261552	261553	261554	261555	261556	261560 ^④	261561 ^④

① Total mass of motor with electromagnetic brake ② Total moment of inertia of motor with electromagnetic brake ③ Brake gap cannot be adjusted.
 ④ The item has longer delivery time. Please contact your Mitsubishi Electric representative.

Motor model (400 V)	HG-JR (400)											
	534B	734B	1034B	1534B	2034B	3534B	5034B	7034B	9034B	11K1M4B	15K1M4B	
Type	Spring-loaded safety brake											
Rated voltage	24 V DC											
Static friction torque [Nm]	6.6	6.6	6.6	6.6	6.6	16	16	44	44	126	126	
Rated current at 20 °C [A]	0.5	0.5	0.5	0.5	0.5	1.0	1.0	1.4	1.4	1.3	1.3	
Coil resistance at 20 °C [Ω]	49	49	49	49	49	25	25	16.8	16.8	18	18	
Power consumption at 20 °C [W]	11.7	11.7	11.7	11.7	11.7	23	23	34	34	32	32	
Moment of inertia J ^② [$\times 10^{-4}$ kg m ²]	2.02	2.59	3.15	4.29	5.42	15.4	21.2	52.9	65.4	240	336	
Permissible braking volume [J]/time	64	64	64	64	64	400	400	4500	4500	5000	5000	
[J]/hour	640	640	640	640	640	4000	4000	45000	45000	45200	45200	
Brake life [times] ^③	5000	5000	5000	5000	5000	5000	5000	20000	20000	20000	20000	
Brake volume per brake action [J]	64	64	64	64	64	400	400	1000	1000	400	400	
Weight ^① [kg]	4.4	5.1	5.9	7.3	8.9	15	20	35	42	74	97	
Order information	Art. no.	261454	261455	261456	261457	261458	261459	261460	261382	261383	261537 ^④	261538 ^④

① Total mass of motor with electromagnetic brake ② Total moment of inertia of motor with electromagnetic brake ③ Brake gap cannot be adjusted.
 ④ The item has longer delivery time. Please contact your Mitsubishi Electric representative.

MR-JE Servo Amplifier Specifications

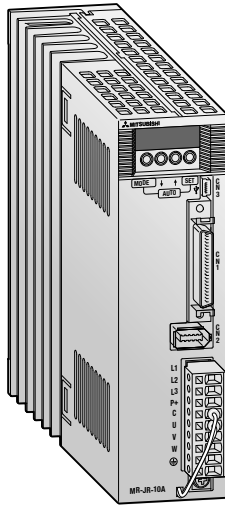

The MR-JE was designed to reach high performance and to get an easy-to-use servo system for all kind of machines. Proven reliability with a 2.0 kHz highfrequency response, an energy-saving design and the easy setup with Advanced One-Touch Tuning can be offered by MR-JE. The servo motors are equipped with 131072 pulses/rev (17-bit) incremental encoder

for achieving high-accuracy positioning and smooth rotation for applications from 100 W to 3 kW. In combination with the MR Configurator2 software package the servo system is easy to start-up, to adjust and to analyze.

Servo amplifier MR-JE		10A	20A	40A	70A	100A	200A	300A	
Power supply		3-phase 200–230 V AC, 50/60 Hz; 1-phase 200–240 V AC, 50/60 Hz				3-phase 200–240 V AC, 50/60 Hz			
Control system		Sinusoidal PWM control/current control system							
Dynamic brake		Built-in							
Protective functions		Overcurrent shutdown, regeneration overvoltage shutdown, overload shutdown (electronic thermal), encoder fault protection, regeneration fault protection, undervoltage/sudden power outage protection, overspeed protection, excess error protection							
Structure/protection		Self-cooling, open (IP20)					Fan-cooling, open (IP20)		
Environment	ambient temperature	Operation: 0–55 °C (no freezing); storage: -20–65 °C (no freezing)							
	ambient humidity	Operation: 90 % RH max. (no condensation); storage: 90 % RH max. (no condensation)							
	others	Elevation: 1000 m or less above sea level; oscillation: 5.9 m/s ² (0.6 G) max.							
Position control mode	max. input pulse frequency	4 Mpps (differential receiver), 200 kpps (open collector)							
	positioning feedback pulse	131072 pulses per servo motor rotation							
	torque limit	Set by parameters or external analog input (0–+10 V DC/maximum torque)							
Speed control mode	control range	Analog speed command 1:2000, internal speed command 1:5000							
	fluctuation rate	±0.01 % max. (load fluctuation 0–100 %)							
	torque limit	Set by parameters or external analog input (0–+10 V DC/maximum torque)							
Torque control mode	command input	0–±8 V DC/maximum torque							
	speed limit	Set by parameters or external analog input (0–±10 V DC, rated speed)							
Weight	kg	0.8	0.8	0.8	1.5	1.5	2.1	2.1	
Dimensions (WxHxD)	mm	50x168x135	50x168x135	50x168x135	70x168x185	70x168x185	90x168x195	90x168x195	
Order information		Art.-Nr.	268792	268793	268794	268795	268796	268797	268798

MR-J4 Servo Amplifier Specifications (200 V Type)

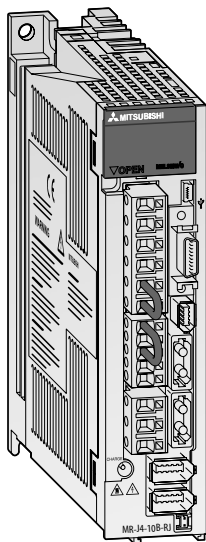

The MELSERVO MR-J4 series is designed for ease of use and setup, safety, energy-efficiency and user friendly handling. With additional functions like “One-touch Tuning” and “Advanced Vibration Suppression Control” the servo performance achieves industry-leading level. The range covers 100 W units through to 22 kW.

- Processing of encoder signals with 22 bit resolution (4194304 pulses/rev.)
- Speed frequency response is increased to 2.5 kHz
- Operating of rotary, linear and direct drive motors as standard
- Compatible with integrated safety functions STO (Safe Torque Off) corresponding EN 61800-5-2 as standard.

- In combination with the MR-D30 functional safety unit, the MR-J4-B-RJ amplifier series can be expanded by the additional EN 61800-5-2 safety functions SS1, SBC, SSM and SLS.

The MR-J4-B servo amplifier receives a command signal from a control system via high speed motion network SSCNETIII/H with a communication speed of 150 Mbps and a cycle time of 0.22 ms. This optical network is very reliable in operation because it is not affected by EMC.

For control, the MR-J4-A servo amplifier has a pulse train input and two analog inputs for current or voltage. Possible modes are torque, speed or position control. In addition the MR-J4-A-RJ has an integrated positioning function. Simple positioning tasks can be realized directly from the servo amplifier.

Common specifications MR-J4-A/B		10A-RJ 10B-RJ	20A-RJ 20B-RJ	40A-RJ 40B-RJ	60A-RJ 60B-RJ	70A-RJ 70B-RJ	100A-RJ 100B-RJ	200A-RJ 200B-RJ	350A-RJ 350B-RJ	500A-RJ 500B-RJ	700A-RJ 700B-RJ	11KA-RJ 11KB-RJ	15KA-RJ 15KB-RJ	22KA-RJ 22KB-RJ	
Power supply	voltage /frequency ①	1-phase or 3-phase 200–240 V AC, 50/60 Hz						3-phase 200–240 V AC, 50/60 Hz							
	permissible voltage fluctuation	1-phase or 3-phase 170–264 V AC						3-phase 170–264 V AC							
	permissible frequency fluctuation	±5 % max.													
Control system	Sinusoidal PWM control/current control system														
Dynamic brake	Built-in											External option			
Speed frequency response	2500 Hz														
Protective functions	Overcurrent shutdown, regeneration overvoltage shutdown, overload shutdown (electronic thermal), servomotor overheat protection, encoder fault protection, regeneration fault protection, undervoltage/sudden power outage protection, overspeed protection, excess error protection.														
Safety function	STO (IEC/EN 61800-5-2); (The functions SS1, SBC, SLS and SSM are available in combination with the optional functional safety unit MR-D30.)														
Structure	Self-cooling, open (IP20)						Fan cooling, open (IP20)								
Environment	ambient temperature	Operation: 0–55 °C (no freezing), storage: –20–65 °C (no freezing)													
	ambient humidity	Operation: 90 % RH max. (no condensation), storage: 90 % RH max. (no condensation)													
	atmosphere	Inside control panel; no corrosive gas, no flammable gas, no oil mist, no dust													
	elevation	1000 m or less above sea level													
	oscillation	5.9 m/s ² (0.6 G) max.													
Weight	kg	0.8	0.8	1.0	1.0	1.4	1.4	2.1	2.3	4.0	6.2	13.4	13.4	18.2	
Dimensions (WxHxD)	mm	40x	40x	40x	40x	60x	60x	90x	90x	105x	172x	220x	220x	260x	
		168x135	168x135	168x170	168x170	168x185	168x185	168x195	168x195	250x200	300x200	400x260	400x260	400x260	

Order information		A type	Art. no.	269247	269248	269249	269250	269251	269252	269253	269254	269265	269266	269267	269268	269269
		B type	Art. no.	269279	269280	269281	269282	269283	269284	269285	269286	269287	269288	269289	269290	269291

① Rated output capacity and rated rotation speed of the servo motor used in combination with the servo amplifier are as indicated when using the power voltage and frequency listed. Output and speed cannot be guaranteed when the power supply voltage is less than specified.

Control specifications MR-J4-A		10A-RJ	20A-RJ	40A-RJ	60A-RJ	70A-RJ	100A-RJ	200A-RJ	350A-RJ	500A-RJ	700A-RJ	11KA-RJ	15KA-RJ	22KA-RJ
Position control mode	maximum input pulse frequency	4 Mpps (when using differential receiver), 200 kpps (when using open collector)												
	positioning feedback pulse	Resolution per encoder/servo motor rotation: 4194304 pulses/revolution (22 Bit)												
	command pulse multiple	Electronic gear A/B multiple; A: 1–16777216, B: 1–16777216, 1/10 <A/B <4000												
Speed control mode	torque limit input	Set by parameters or external analog input (0–± 10 V DC/maximum torque)												
	speed control range	Analog speed command 1:2000, internal speed command 1:5000												
	analog speed command input	0–± 10 V DC/rated speed (The speed at 10 V can be changed by parameter)												
Torque control specifications	speed fluctuation rate	±0.01 % max. (load fluctuation 0–100 %); 0 % (power fluctuation ±10 %) ±0.2 % max. (ambient temperature 25 °C ±10 °C), when using external analog speed command												
	torque limit	Set by parameters or external analog input (0–± 10 V DC/maximum torque)												
Integrated positioning	torque command input	0–±8 V DC/maximum torque (input impedance 10–12 kΩ)												
	speed limit	Set by parameters or external analog input (0–± 10 V DC, rated speed)												
Integrated positioning	position tables	255 table entries for target position, set speed value, acceleration/deceleration time, braking												
	programming style	256 programs, 640 program steps, 25 commands												
	indexing function	255 stations, rotational direction tightly adjustable or automatically shortest path												

Control specifications MR-J4-B (SSCNETIII/H)		10B-RJ	20B-RJ	40B-RJ	60B-RJ	70B-RJ	100B-RJ	200B-RJ	350B-RJ	500B-RJ	700B-RJ	11KB-RJ	15KB-RJ	22KB-RJ
Position and speed control	Possible using SSCNETIII/H control													
Communication speed	150 Mbps													

MR-J4 Servo Amplifier Specifications (400 V Type)

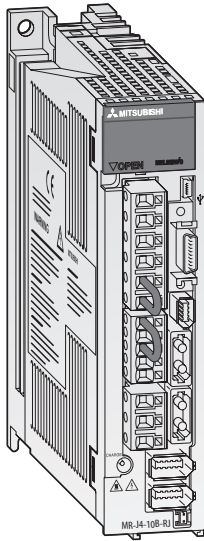

The MELSERVO MR-J4 servo amplifiers for 400 V power supply offer the same industry leading performance as the 200 V types. The range of rated output is from 600 W to 22 kW.

Common specifications MR-J4-A4/B4		60A4-RJ 60B4-RJ	100A4-RJ 100B4-RJ	200A4-RJ 200B4-RJ	350A4-RJ 350B4-RJ	500A4-RJ 500B4-RJ	700A4-RJ 700B4-RJ	11KA4-RJ 11KB4-RJ	15KA4-RJ 15KB4-RJ	22KA4-RJ 22KB4-RJ
Power supply	voltage /frequency ^①	3-phase 380–480 V AC, 50/60 Hz								
	permissible voltage fluctuation	3-phase 323–528 V AC, 50/60 Hz								
	permissible frequency fluctuation	±5 % max.								
Control system		Sinusoidal PWM control/current control system								
Dynamic brake		Built-in								
Speed frequency response		2500 Hz								
Protective functions		Overcurrent shutdown, regeneration overvoltage shutdown, overload shutdown (electronic thermal), servomotor overheat protection, encoder fault protection, regeneration fault protection, undervoltage/sudden power outage protection, overspeed protection, excess error protection.								
Safety function		STO (IEC/EN 61800-5-2); (The functions SS1, SBC, SLS and SSM are available in combination with the optional functional safety unit MR-D30.)								
Structure		Self-cooling, open (IP20)					Fan cooling, open (IP20)			
Environment	ambient temperature	Operation: 0–55 °C (no freezing), storage: –20–65 °C (no freezing)								
	ambient humidity	Operation: 90 % RH max. (no condensation), storage: 90 % RH max. (no condensation)								
	atmosphere	Inside control panel; no corrosive gas, no flammable gas, no oil mist, no dust								
	elevation	1000 m or less above sea level								
	oscillation	5.9 m/s ² (0.6 G) max.								
Weight	kg	1.7	1.7	2.1	3.6	4.3	6.5	13.4	13.4	18.2
Dimensions (WxHxD)	mm	60x168x195	60x168x195	90x168x195	105x250x200	130x250x200	172x350x200	220x400x260	220x400x260	260x400x260
Order information										
A type	Art. no.	269270	269271	269272	269273	269274	269275	269276	269277	269278
B type	Art. no.	269292	269293	269294	269295	269296	269297	269298	269299	269300

① Rated output capacity and rated rotation speed of the servo motor used in combination with the servo amplifier are as indicated when using the power voltage and frequency listed. Output and speed cannot be guaranteed when the power supply voltage is less than specified.

Control specifications MR-J4-A4		60A4-RJ	100A4-RJ	200A4-RJ	350A4-RJ	500A4-RJ	700A4-RJ	11KA4-RJ	15KA4-RJ	22KA4-RJ
Position control mode	maximum input pulse frequency	4 Mpps (when using differential receiver), 200 kpps (when using open collector)								
	positioning feedback pulse	Resolution per encoder/servo motor rotation: 4194304 pulses/revolution (22 Bit)								
	command pulse multiple	A/B multiple; A: 1–16777215, B: 1–16777215, 1/10 <A/B <4000								
Speed control mode	torque limit input	Set by parameters or external analog input (0–±10 V DC/maximum torque)								
	speed control range	Analog speed command 1:2000, internal speed command 1:5000								
	analog speed command input	0–±10 V DC/rated speed (The speed at 10 V can be changed by parameter.)								
Torque control specifications	speed fluctuation rate	±0.01 % max. (load fluctuation 0–100 %); 0 % (power fluctuation ±10 %) ±0.2 % max. (ambient temperature 25 °C ±10 °C), when using external analog speed command								
	torque limit	Set by parameters or external analog input (0–±10 V DC/maximum torque)								
	torque command input	0–±8 V DC/maximum torque (input impedance 10–12 kΩ)								
Integrated positioning	speed limit	Set by parameters or external analog input (0–±10 V DC, rated speed)								
	position tables	255 table entries for target position, set speed value, acceleration/deceleration time, braking								
	programming style	256 programs, 640 program steps, 25 commands								
	indexing function	255 stations, rotational direction tightly adjustable or automatically shortest path								

Control specifications MR-J4-B4 (SSCNETIII/H)		60B4-RJ	100B4-RJ	200B4-RJ	350B4-RJ	500B4-RJ	700B4-RJ	11KB4-RJ	15KB4-RJ	22KB4-RJ
Position and speed control		Possible using SSCNETIII/H control								
Communication speed		150 Mbps								

MR-J4W2-B/MR-J4W3-B Servo Amplifier Specifications

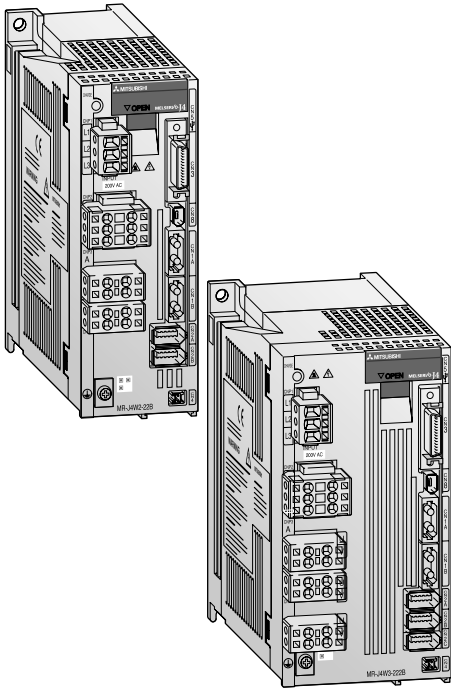

Additional to the standard version of the MR-J4 amplifiers (SSCNETIII/H Motion Network) for one servo motor Mitsubishi Electric now offers also servo amplifiers for two or three servo motors. The amplifiers for two (MR-J4W2-B) and three axes (MR-J4W3-B) are space and wiring saving and more efficient than two or three single amplifiers. Therefore the engineer saves not only space inside the cabinet and costs due to less wires, but also valuable energy what reduces the pollution of CO₂ at the same time. The range of output power for the amplifier for

two axes is from 0.2 to 1 kW, for three axes from 0.2 to 0.4 kW per axis. All other specification items are identical with the standard version of the MR-J4-B for one axis.

3

Servo Amplifier

Common specifications MR-J4W-B		W2-22B	W2-44B	W2-77B	W2-1010B	W3-222B	W3-444B	
Power supply	voltage /frequency ^①	1-phase or 3-phase 200–240 V AC, 50/60 Hz			3-phase 200–240 V AC, 50/60 Hz	1-phase or 3-phase 200–240 V AC, 50/60 Hz		
	permissible voltage fluctuation	1-phase or 3-phase 170–264 V AC			3-phase 170–264 V AC	1-phase or 3-phase 170–264 V AC		
	permissible frequency fluctuation	±5 % max.						
Control system		Sinusoidal PWM control/current control system						
Dynamic brake		Built-in						
Speed frequency response		2500 Hz						
Protective functions		Overcurrent shutdown, regeneration overvoltage shutdown, overload shutdown (electronic thermal), servomotor overheat protection, encoder fault protection, regeneration fault protection, undervoltage/sudden power outage protection, overspeed protection, excess error protection.						
Safety function		STO (IEC/EN 61800-5-2)						
Structure		Self-cooling, open (IP20)		Fan cooling, open (IP20)				
Environment	ambient temperature	Operation: 0–55 °C (no freezing), storage: –20–65 °C (no freezing)						
	atmosphere	Inside control panel; no corrosive gas, no flammable gas, no oil mist, no dust						
	elevation	1000 m or less above sea level						
	oscillation	5.9 m/s ² (0.6 G) max.						
Weight	kg	1.5	1.5	2.0	2.0	1.9	1.9	
Dimensions (WxHxD)	mm	60x168x195	60x168x195	85x168x195	85x168x195	85x168x195	85x168x195	
Order information		Art. no.	248645	248646	248647	248648	248649	248650

^① Rated output capacity and rated rotation speed of the servo motor used in combination with the servo amplifier are as indicated when using the power voltage and frequency listed. Output and speed cannot be guaranteed when the power supply voltage is less than specified.

MR-D30 Functional Safety Unit

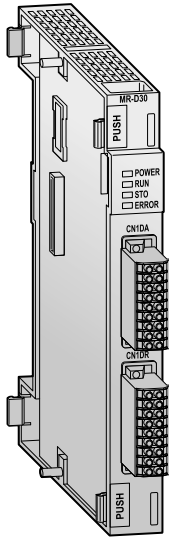

In combination with the optional MR-D30 functional safety unit, additional safety functions according to EN IEC 61800-5-2 can be realized. By combining the MR-D30 functional safety unit with a MR-J4-B-RJ servo amplifier, safety functions "Safe Stop" (SS1), "Safe Brake Control" (SBC), "Safely Limited Speed" (SLS) and "Safe Speed Monitor" (SSM) according to EN IEC 61800-5-2 are available.

The activation is possible by wiring the signals directly to the MR-D30 or in combination with the Motion Controller via a safe SSCNETIII/H communication. Additionally the wiring will be reduced by activating via network.

Common specifications		MR-D30
Control power supply	voltage /frequency	24 V DC
	permissible voltage fluctuation	24 V DC \pm 10 %
	power supply capacity	800 mA
Supported amplifiers		MR-J4-□B-RJ
Shut-off input (Safety devices)		6 redundant input points, source or sink logic
Shut-off release input (restart devices)		3 redundant output points, source logic
Response time		15 ms or less for Safe Torque Off (STO)
Environment	ambient temperature	Operation: 0–55 °C (no freezing), storage: -20–65 °C (no freezing)
	ambient humidity	Operation: 90 % RH or less (no condensation), storage: 90 % RH or less (no condensation)
	atmosphere	Inside control panel; no corrosive gas, no flammable gas, no oil mist, no dust
	elevation	1000 m or less above sea level
	oscillation	5.9 m/s ² or less at 10 to 57 Hz (directions of X, Y and Z axes)
Weight	kg	0.15
Dimensions (WxHxD)	mm	22.5x192x86
Order information		Art. no. 275670

Safety specifications		MR-D30
Safety standards		EN ISO 13849-1 category 3 PL d and category 4 PL e IEC 61508 SIL 2 and SIL 3 EN 62061 SIL CL 2 and SIL CL 3 EN 61800-5-2 SIL 2 and SIL 3
Response time		15 ms or less for Safe Torque Off (STO)
Safety functions		<ul style="list-style-type: none"> ● Safe Torque Off (STO) (SIL 2, category 3 PL d/SIL 3, category 4 PL e by direct wiring) ● Safe Stop 1 (SS1) (SIL 2, category 3 PL d/SIL 3, category 4 PL e by direct wiring) ● Safe Brake Control (SBC) (SIL 2, category 3 PL d/SIL 3, category 4 PL e by direct wiring) ● Safely Limited Speed (SLS) (SIL 2, category 3 PL d) ● Safe Speed Monitor (SSM) (SIL 2, category 3 PL d)
MTTFd Expectation of the average time for a dangerous failure to occur		\geq 100 years
DC Diagnostic Coverage (DC) is the effectiveness of fault monitoring of a system or subsystem		\geq 90 %
PFH Average probability of dangerous failure taking place during one (1) hour		6.57×10^{-9} 1/h

MR-J4-A Servo Amplifier Connections with Peripheral Equipment

Peripheral equipment is connected to the MR-J4-A as shown below. To ensure fast, efficient configuration and reliable operation

always use only the connecting cables, expansion options and other accessories supplied or recommended by Mitsubishi Electric.

A complete overview with detailed specifications of all cables and accessories can be found in the next chapter.

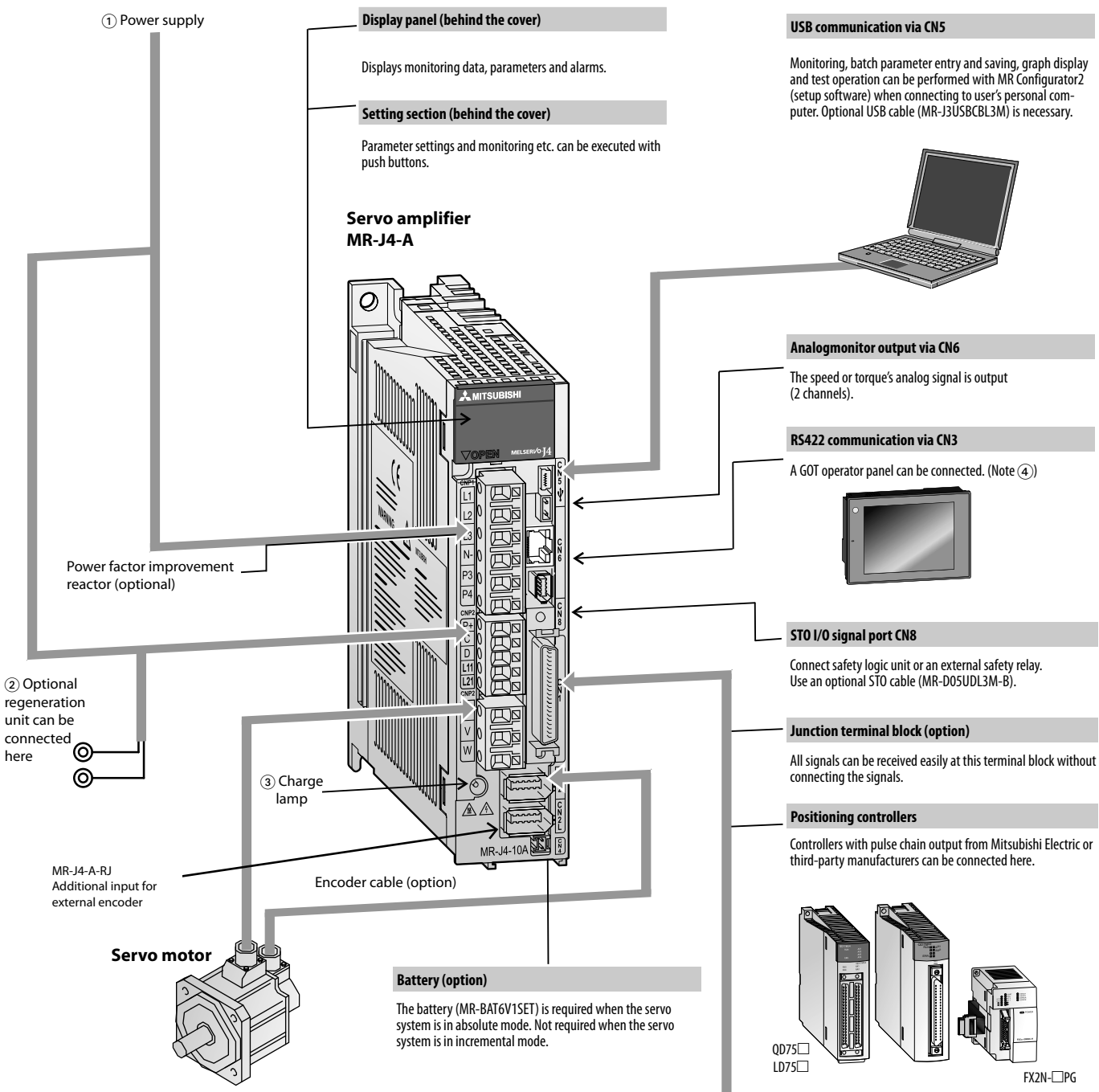

- ① Power supply**
3~, 200–240 V AC
1~, 200–240 V AC for servo drives ≤750 W
3~, 380–400 V AC for servo drives ≥ 600 W (A4)
- ② Regeneration unit (option)**
This unit can be installed in situations involving frequent regeneration and large load inertia moments. For more details refer to the MR-J4-A users manual.

- ③ Charge lamp**
Lights up when the main power supply is on.
Power lines should not be plugged or unplugged when this lamp is on.
- ④ RS422 Communication**
A personal computer can be connected using a RS-422/RS-232C converter and a conversion cable.

USB communication via CN5
Monitoring, batch parameter entry and saving, graph display and test operation can be performed with MR Configurator2 (setup software) when connecting to user's personal computer. Optional USB cable (MR-J3USBCL3M) is necessary.



Analog monitor output via CN6
The speed or torque's analog signal is output (2 channels).

RS422 communication via CN3
A GOT operator panel can be connected. (Note ④)



STO I/O signal port CN8
Connect safety logic unit or an external safety relay. Use an optional STO cable (MR-D05UDL3M-B).

Junction terminal block (option)
All signals can be received easily at this terminal block without connecting the signals.

Positioning controllers
Controllers with pulse chain output from Mitsubishi Electric or third-party manufacturers can be connected here.

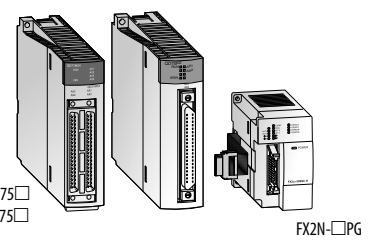

Control signal
Connected to the programmable controllers I/O port like FX3G, FX3GC, FX3U, FX3UC, L series or the machine's operation panel.

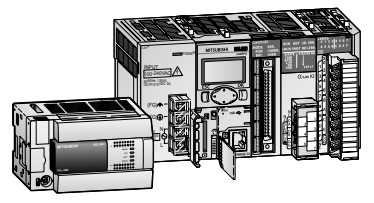

MR-J4-B Servo Amplifier Connections with Peripheral Equipment

Peripheral equipment is connected to the MR-J4-B as shown below. Connectors, cables, options, and other necessary equipment are available so that users can set up MR-J4-B easily and begin using it right away.

Through its SSCNETIII/H-compatible simple connections (optical fibre bus, 150 Mbps), the MR-J4-B series reduce wiring time and chances of wiring errors.

A complete overview with detailed specifications of all cables and accessories can be found in the next chapter.

Motion Controller MELSEC System Q:
Q172DSCPU (for max. 16 axes control)
Q173DSCPU (for max. 32 axes control)

Motion-/ Positioning modules
MELSEC FX: FX3U-20SSC-H
MELSEC System Q: QD75MH

Stand Alone Motion-Controller
MR-MQ100, Q170MSCPU

Simple Motion Module
MELSEC System Q: QD77MS
MELSEC L series: LD77MS

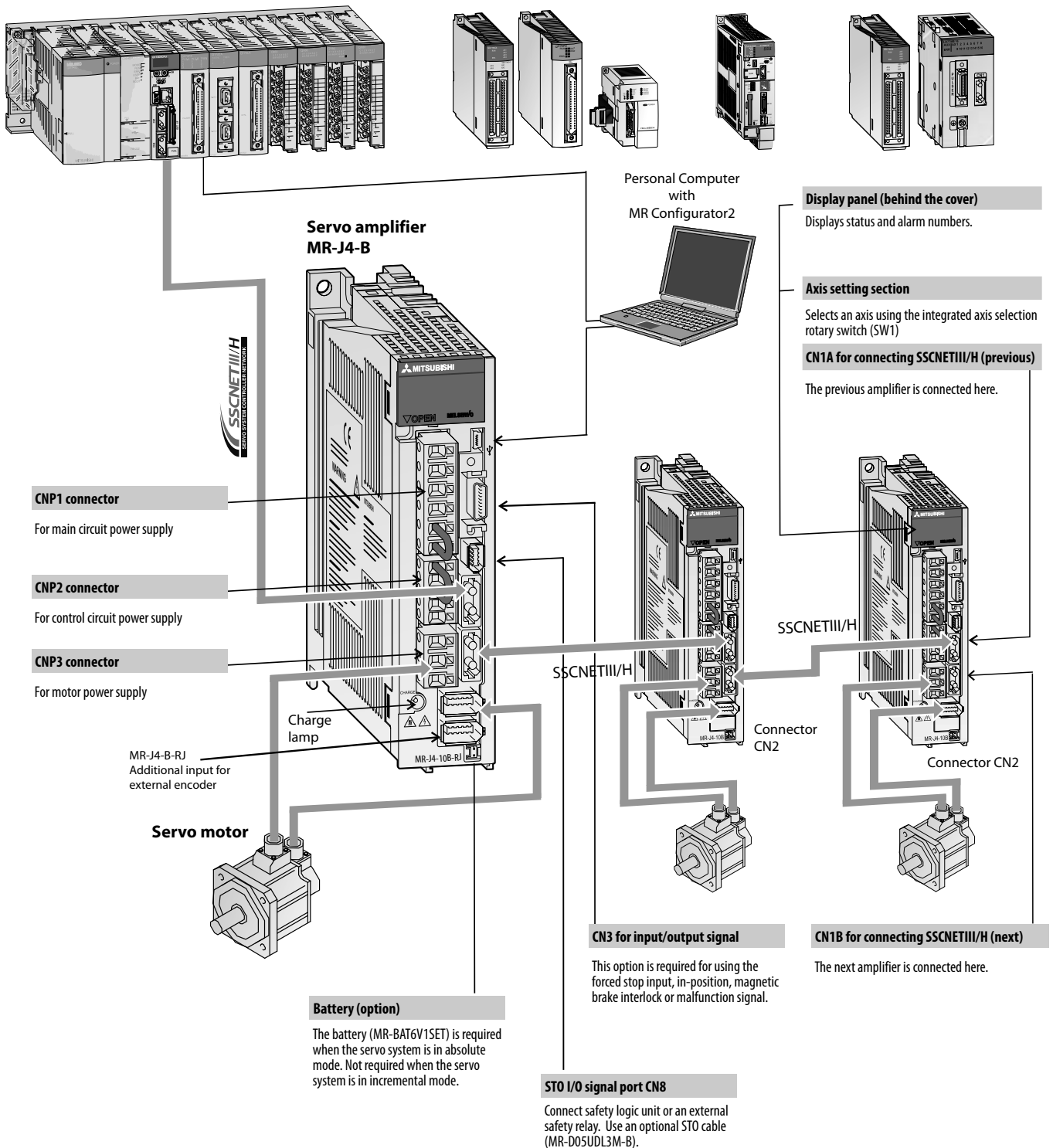

MR-JE Servo Amplifier Connections with Peripheral Equipment

Peripheral equipment is connected to the MR-JE as shown below. To ensure fast, efficient configuration and reliable operation always use

only the connecting cables, expansion options and other accessories supplied or recommended by Mitsubishi Electric.

A complete overview with detailed specifications of all cables and accessories can be found in the next chapter.

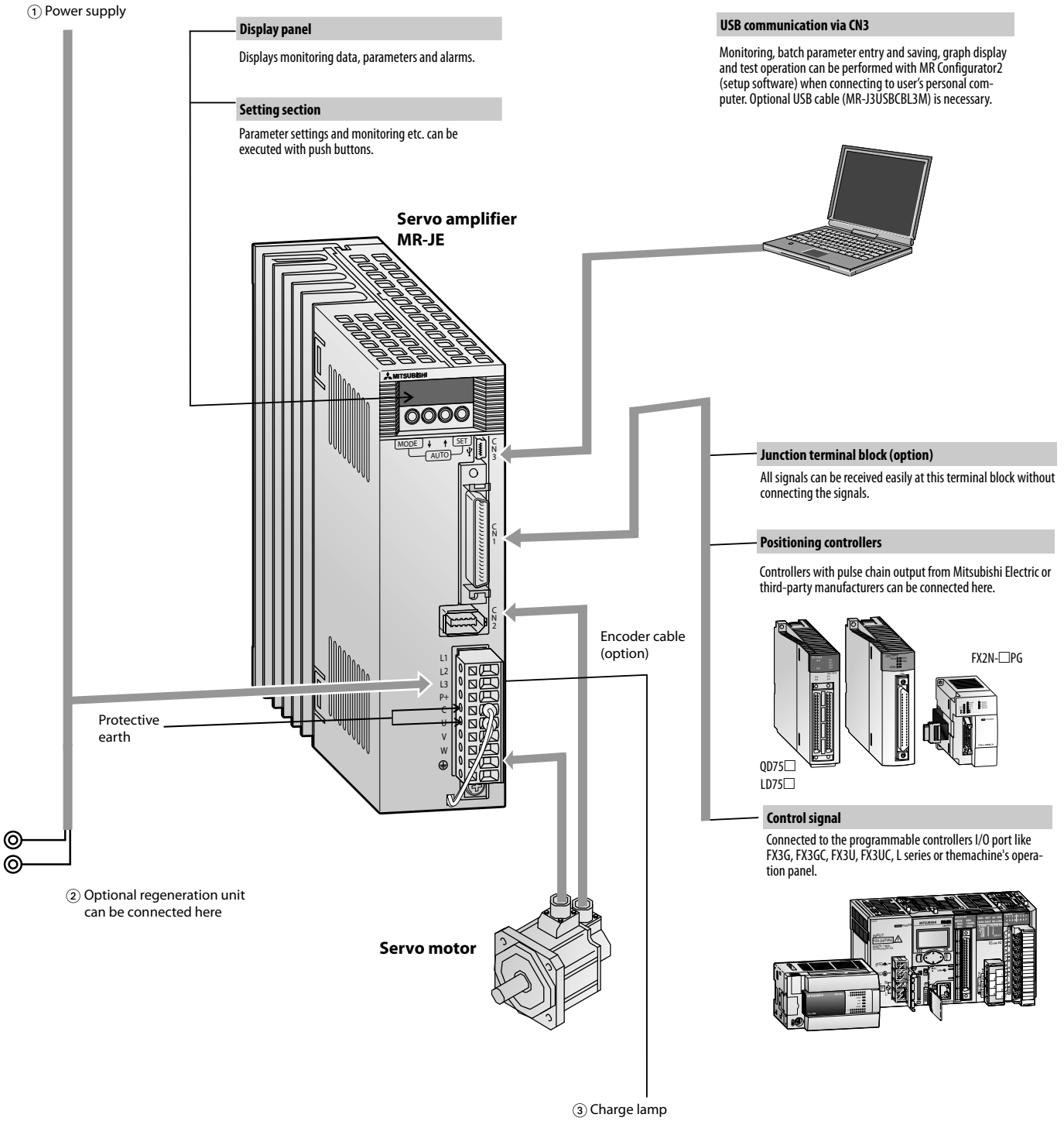

① Power supply
 3~, 200–240 V AC
 1~, 240 V AC for servo drives ≤750 W

② Regeneration unit (option)
 This unit can be installed in situations involving frequent regeneration and large load inertia moments. For more details refer to the MR-JE Instruction manual.

③ Charge lamp
 Lights up when the main power supply is on.
Power lines should not be plugged or unplugged when this lamp is on.

Cables and Connectors for MR-J4-B Servo Amplifiers up to 3.5 kW

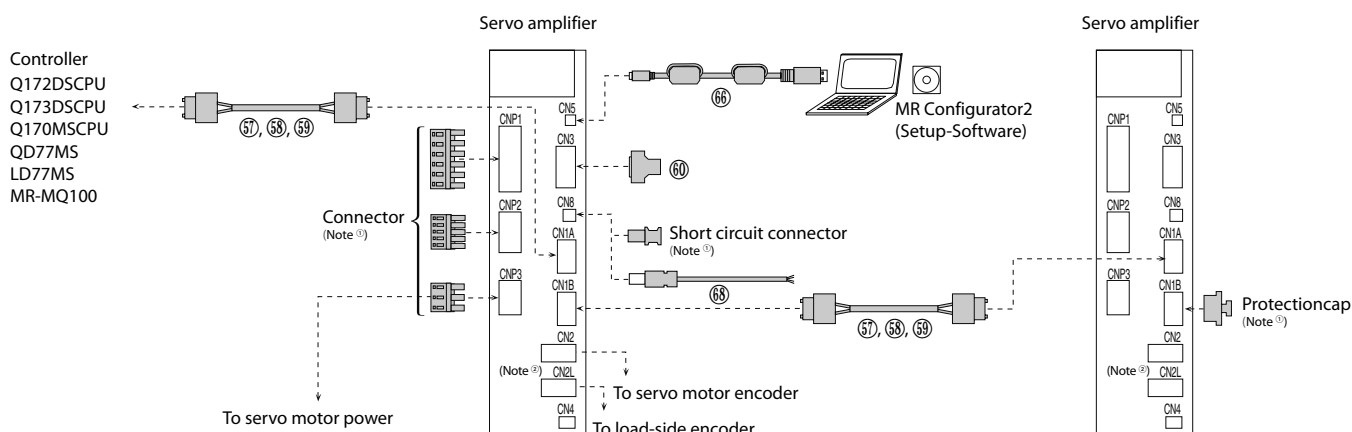

Cables and Connectors for MR-J4-B Servo Amplifiers 5 kW or more

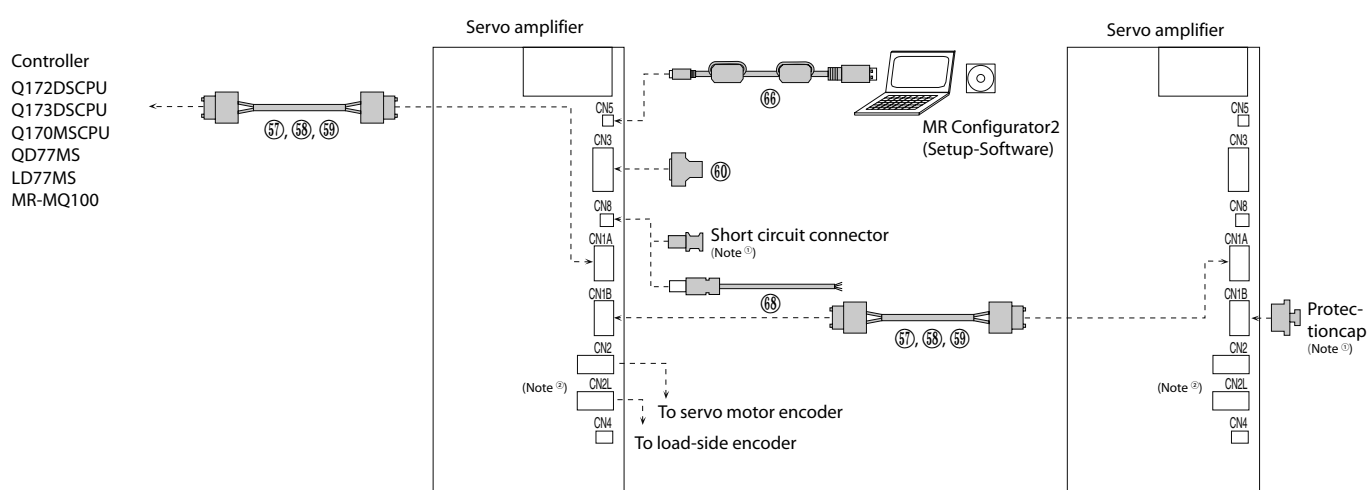

Cables and Connectors for MR-J4W2-B and MR-J4W3-B Servo Amplifiers

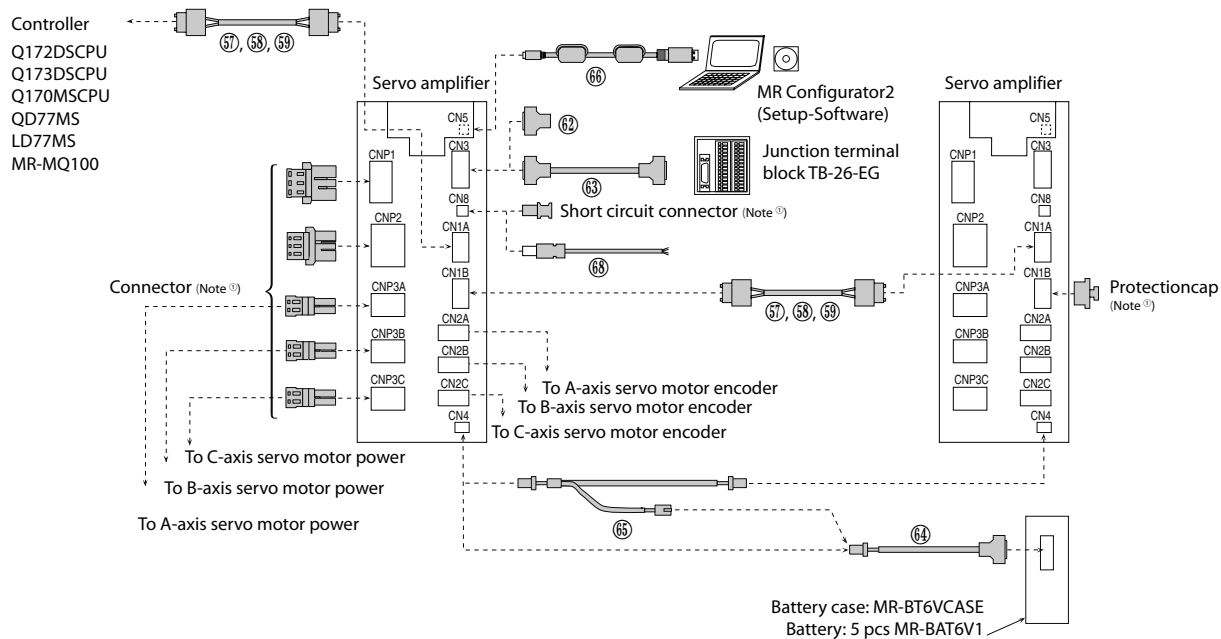

- Notes:
- ① Part of the delivery contents
 - ② CN2L connector is available for MR-J4-B-RJ servo amplifier.

■ Cables and Connectors for MR-J4-A Servo Amplifiers up to 3.5 kW

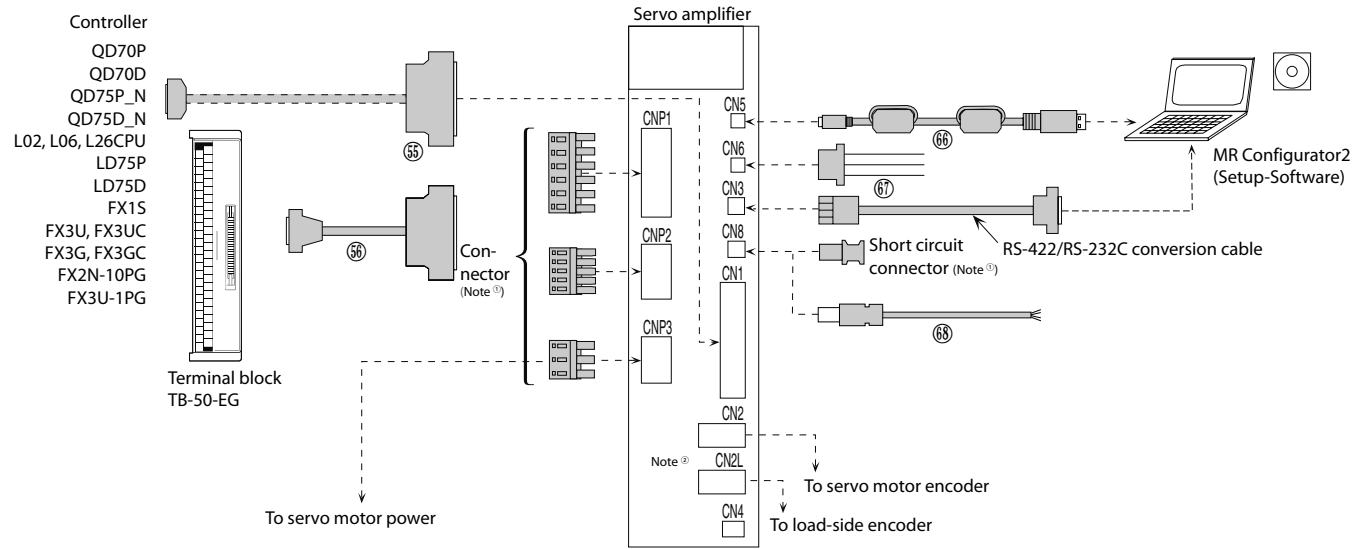

■ Cables and Connectors for MR-J4-A Servo Amplifiers 5 kW or more

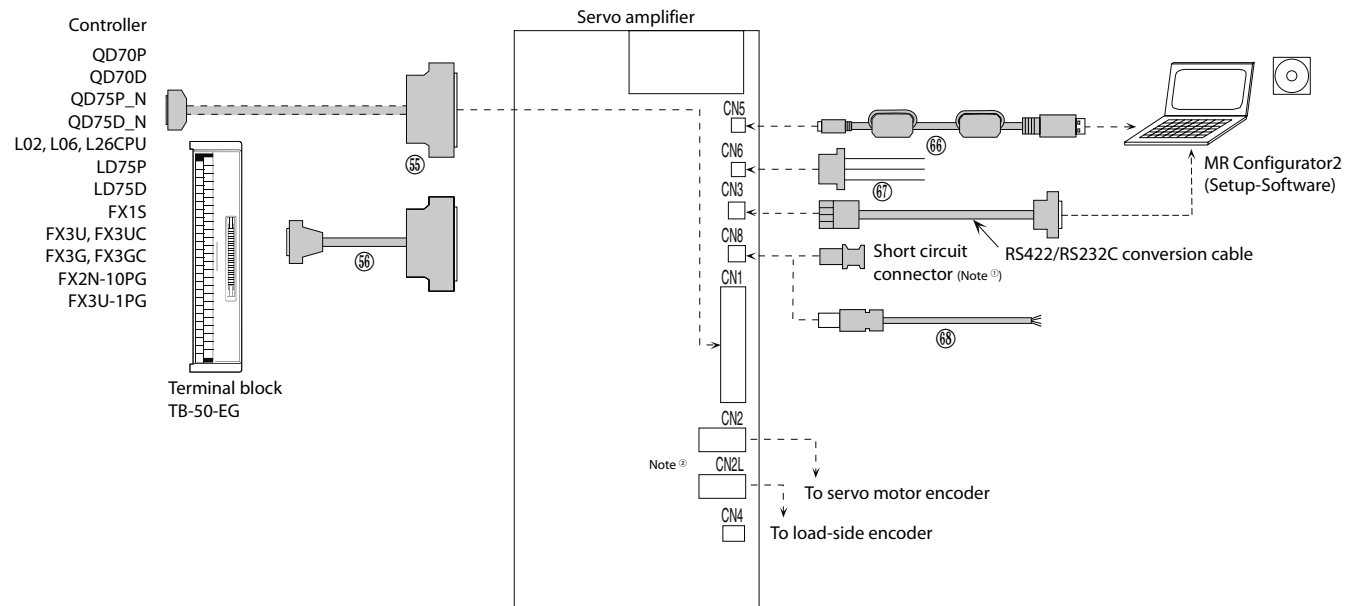

Notes:

- ① Part of the delivery contents
- ② CN2L connector is available for MR-J4-B-RJ servo amplifier.

Cables and Connectors for MR-JE Servo Amplifiers up to 1 kW

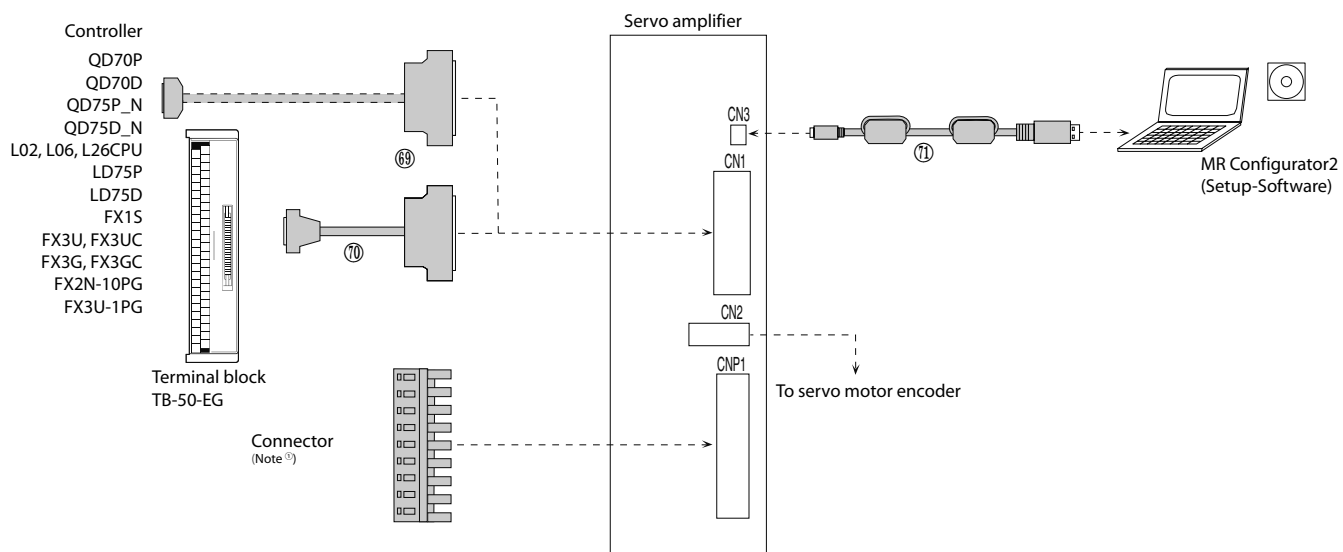

Cables and Connectors for MR-JE Servo Amplifiers 2 kW and 3 kW

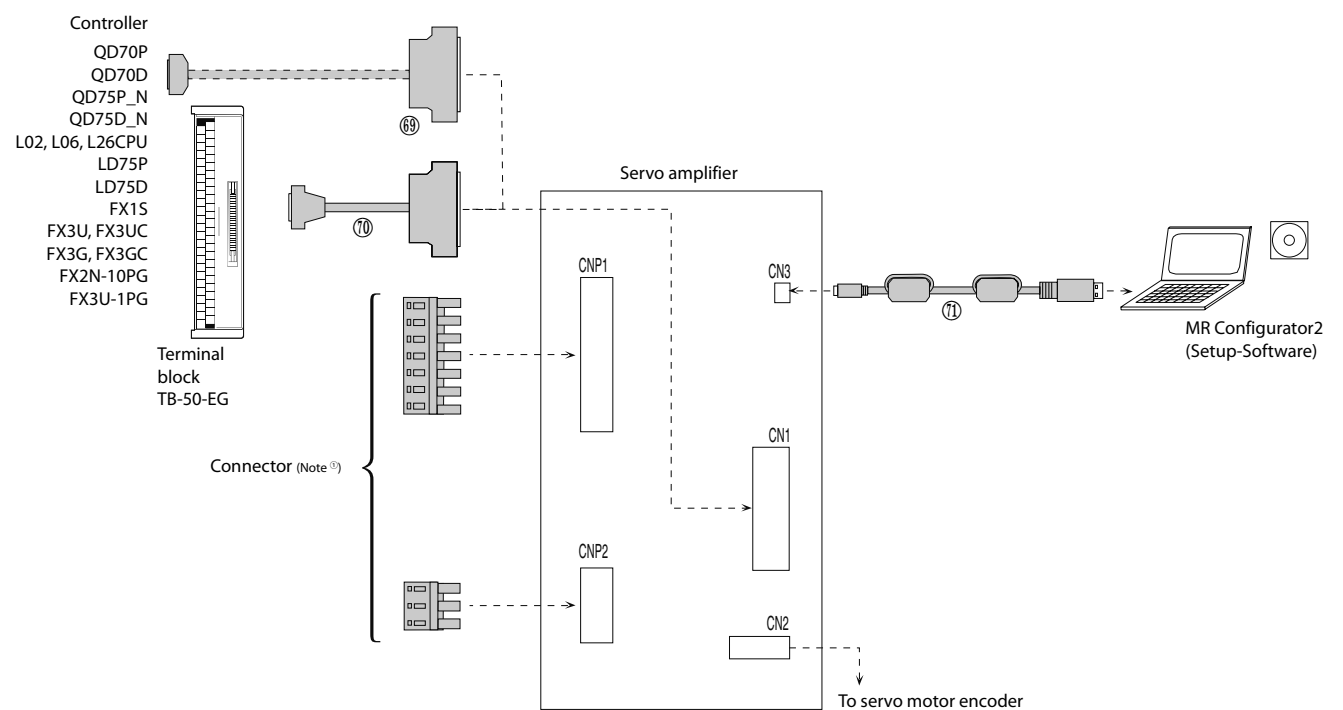

■ Cables and Connectors for Servo Motors

For HG-KR/HG-MR servo motor series: encoder cable length ≤ 10 m

Cables leading in the direction of the motor shaft

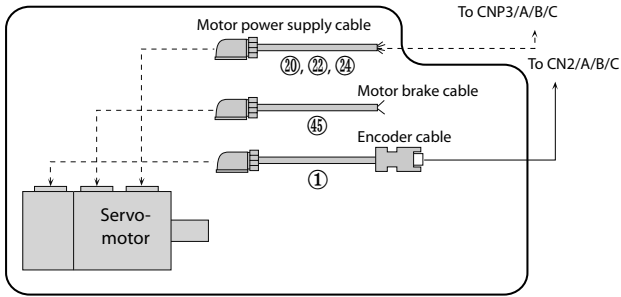

Cables leading in the opposite direction of the motor shaft

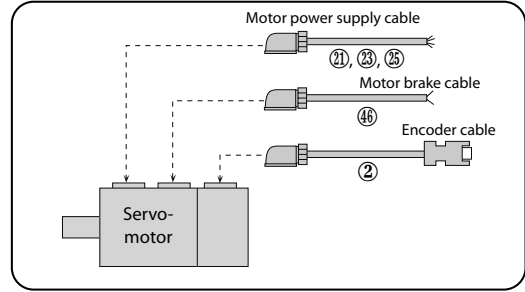

For HG-KR/HG-MR servo motor series: encoder cable length > 10 m

Cables leading in the direction of the motor shaft

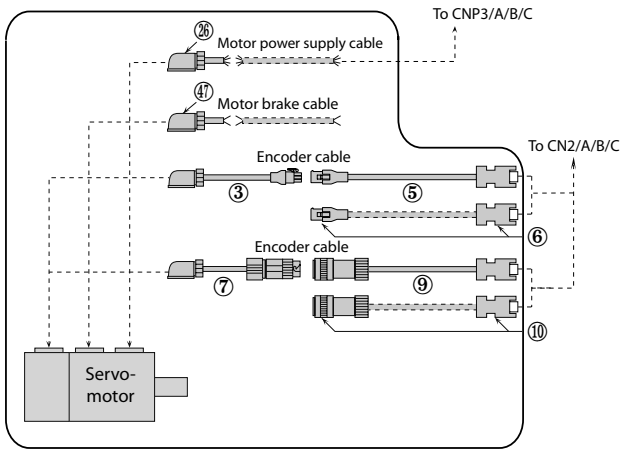

Cables leading in the opposite direction of the motor shaft

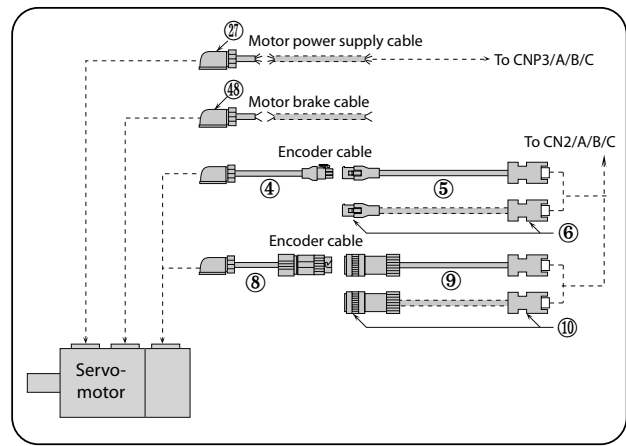

For HG-SR servo motor series

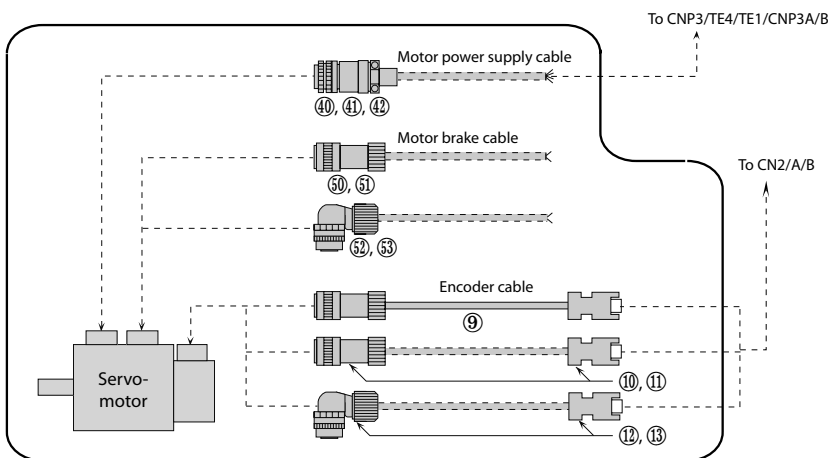

For HG-JR servo motor series ≤9 kW

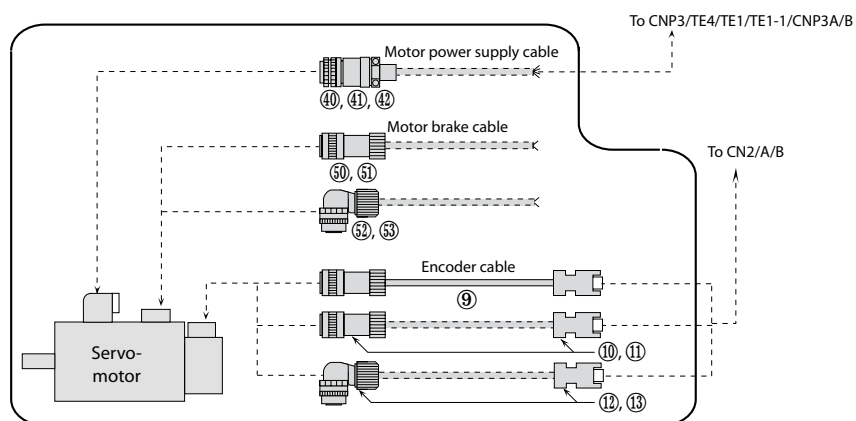

For HG-JR servo motor series 11 kW and 15 kW

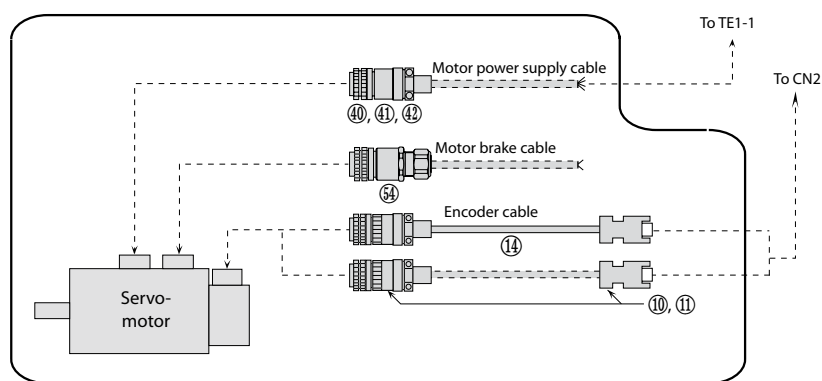

For HG-JR servo motor series 22 kW

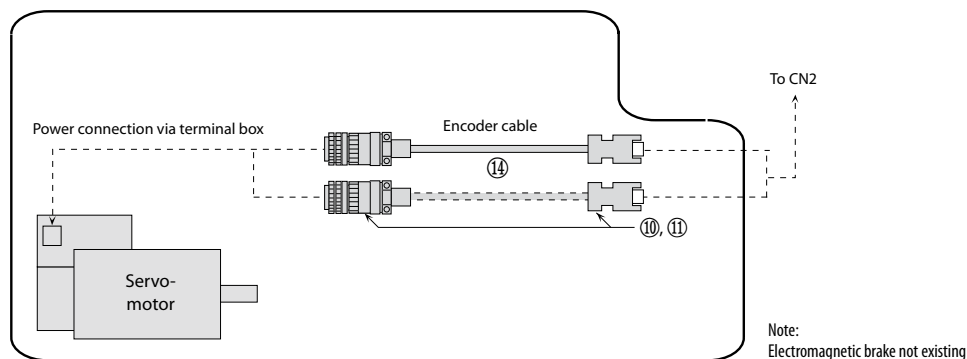

For HG-RR servo motor series

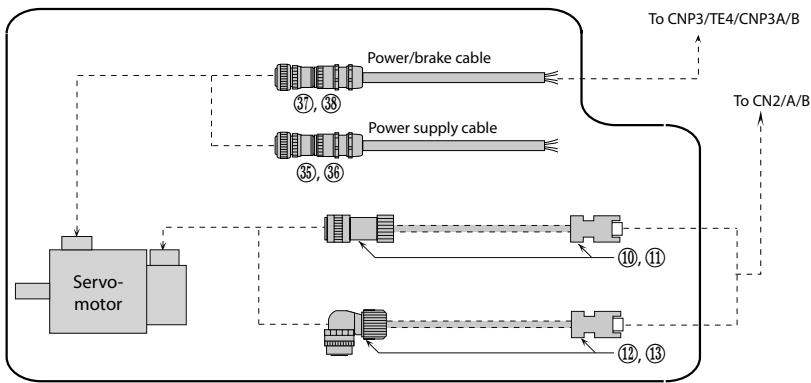

4

For fully closed loop control (MR-J4-B/A or MR-J4W2-B, and rotary servo motor)

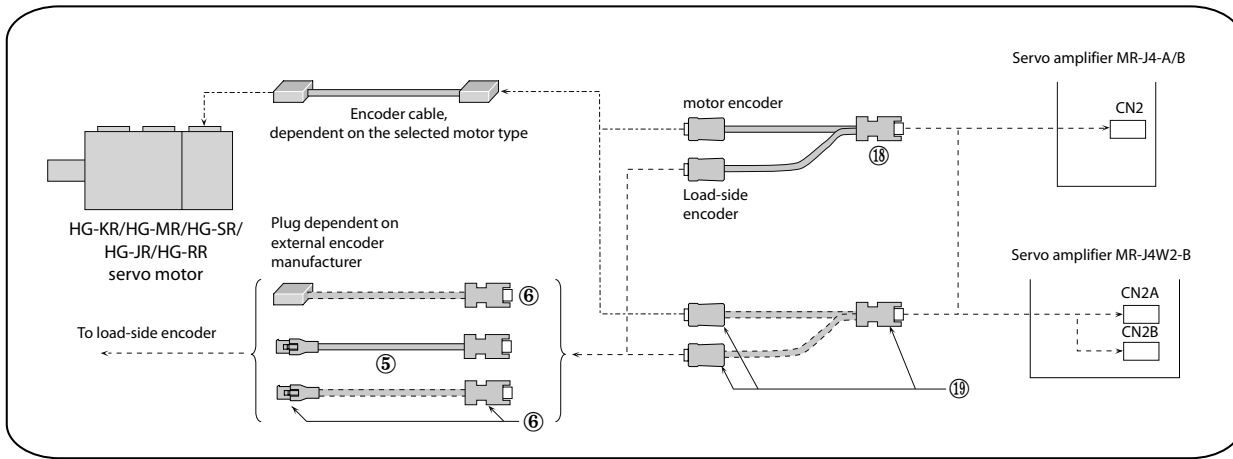

For fully closed loop control (MR-J4-B-RJ/A-RJ and rotary servo motor)

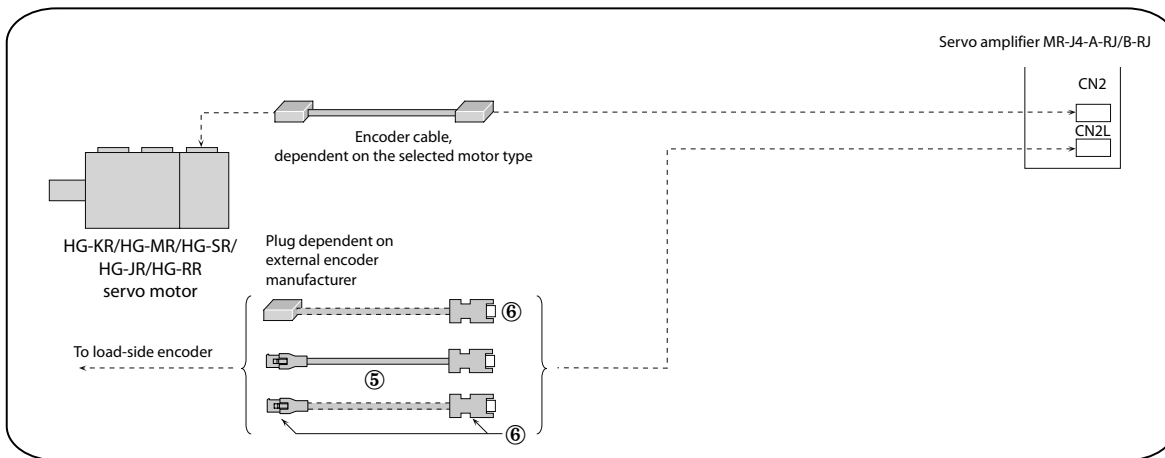

For HF-KN servo motor series: encoder cable length ≤ 10 m

Cables leading in the direction of the motor shaft

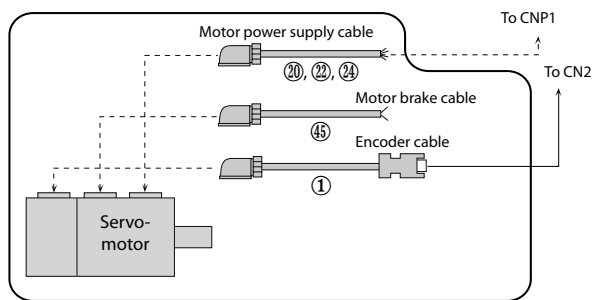

Cables leading in the opposite direction of the motor shaft

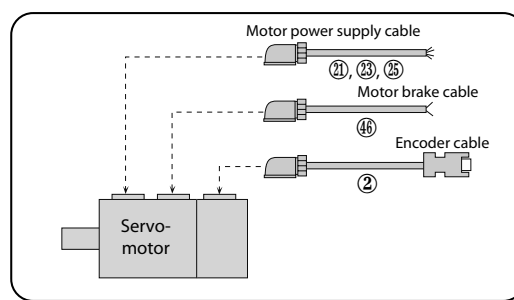

For HF-KN servo motor series: encoder cable length > 10 m

Cables leading in the direction of the motor shaft

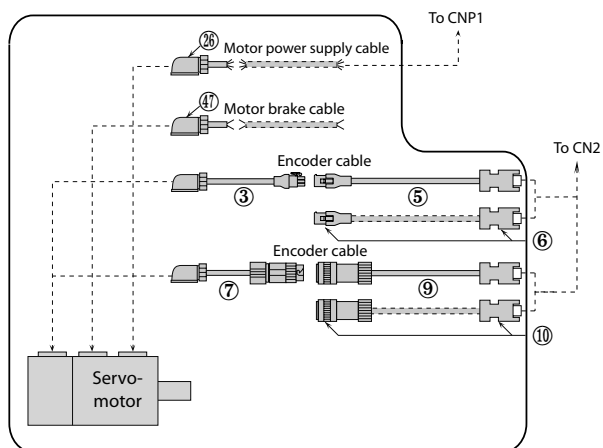

Cables leading in the opposite direction of the motor shaft

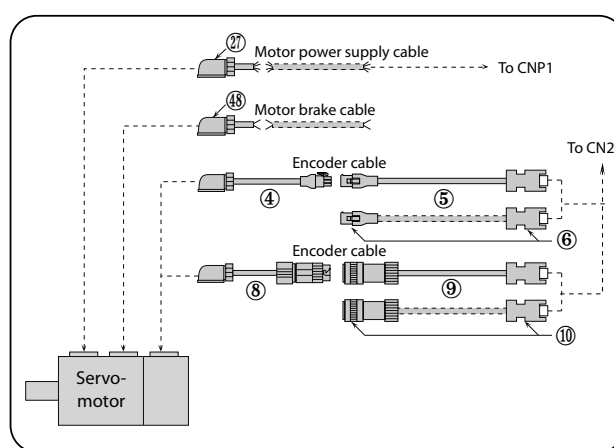



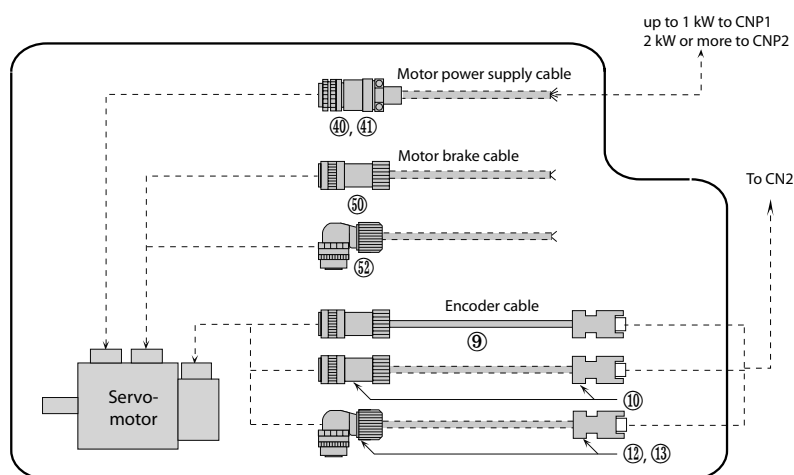



For HF-SN servo motor series



Note:



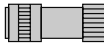

The online servo selection tool on our website helps you to select the right components for your system requirements. The corresponding article numbers of the selected configuration will be listed.

■ Cables and Connectors for Servo Amplifier (general)

Item	Description	Model	Protection	Length	Art. no.	
①	Encoder cable for HG-KR/HG-MR/HF-KN Lead out in direction of motor shaft	Encoder connector (Tyco Electronics AMP) 1674320-1	Amplifier connector 36210-0100PL (receptacle, 3M) 36310-3200-008 (shell kit, 3M) oder 54599-1019 (connector set, Molex)	MR-J3ENCBL□M-A1-H □=Cable length: 2, 5, 10 m ①	IP65	2 m 160312 5 m 161547 10 m 161548
				MR-J3ENCBL□M-A1-L □=Cable length: 2, 5, 10 m ①	IP65	2 m 161549 5 m 161550 10 m 161551
②	Encoder cable for HG-KR/HG-MR/HF-KN Lead out in opposite direction of motor shaft			MR-J3ENCBL□M-A2-H □=Cable length: 2, 5, 10 m ①	IP65	2 m 160230 5 m 161552 10 m 161553
				MR-J3ENCBL□M-A2-L □=Cable length: 2, 5, 10 m ①	IP65	2 m 161554 5 m 161555 10 m 161556
③	Motor-side encoder cable for HG-KR/HG-MR/HF-KN Lead out in direction of motor shaft	Encoder connector (Tyco Electronics AMP) 1674320-1	Junction connector (Tyco Electronics AMP) 1473226-1 (with ring) (contact) 1-172169-9 (housing) 316454-1 (cable clamp)	MR-J3JCBLO3M-A1-L Cable length: 0.3 m ①	IP20	0.3 m 161557
④	Motor-side encoder cable for HG-KR/HG-MR/HF-KN Lead out in opposite direction of motor shaft			MR-J3JCBLO3M-A2-L Cable length: 0.3 m ①	IP20	0.3 m 154367
⑤	Amplifier-side encoder cable for HG-KR/HG-MR/HF-KN	Junction connector (Tyco Electronics AMP) 1-172161-9 (housing) 170359-1 (connector pin) MTI-0002 (cable clamp, TOA ELECTRIC INDUSTRIAL)	Amplifier connector 36210-0100PL (receptacle, 3M) 36310-3200-008 (shell kit, 3M) or 54599-1019 (connector set, Molex)	MR-EKCBL□M-H □=Cable length: 20, 30, 40, 50 m ①	IP20	20 m 161559 30 m 161560 40 m 269075 50 m 229788
				MR-EKCBL□M-L □=Cable length: 20, 30 m ①	IP20	20 m 161561 30 m 161562
⑥	Junction connector, Amplifier-side encoder ② for HG-KR/HG-MR/HF-KN	Junction connector (Tyco Electronics AMP) 1-172161-9 (housing) 170359-1 (connector pin) MTI-0002 (cable clamp, TOA ELECTRIC INDUSTRIAL)	Amplifier connector 54599-1019 (connector set, Molex), or 36210-0100PL (receptacle, 3M) 36310-3200-008 (shell kit, 3M)	MR-ECNM	IP20	— 161572
						
		<Applicable cable example> Wire size: 0.3 mm ² (AWG22) Completed cable outer diameter: Ø 8.2 mm Crimping tool (91529-1) is required.	Use these in combination of ③ or ④.			
⑦	Encoder cable for HG-KR/HG-MR/HF-KN Lead out in direction of motor shaft	Encoder connector (TE Connectivity Ltd. Company) 2174053-1	Junction connector (DDK) CM10-CR10P-M (straight plug)	MR-J3JSCBL03M-A1-L Cable length: 0.3 m ①	IP65	0.3 m 239651
⑧	Encoder cable for HG-KR/HG-MR/HF-KN Lead out in opposite direction of motor shaft			MR-J3JSCBL03M-A2-L Cable length: 0.3 m ①	IP65	0.3 m 239652
⑨	Encoder cable for HG-KR/HG-MR/HG-SR/HG-JR/HG-RR/HF-KN/HF-SN	Encoder connector (DDK) <Für Kabel bis 10 m Länge> CM10-SP10S-M (straight plug) CM10-#225C(C1)-100 (socket contact)	Amplifier connector 36210-0100PL (receptacle, 3M) 36310-3200-008 (shell kit, 3M) oder 54599-1019 (connector set, Molex)	MR-J3ENSCBL□M-H □=Cable length: 2, 5, 10, 20, 30, 40, 50 m ①	IP67	2 m 160226 5 m 161563 10 m 161564 20 m 161565 30 m 161566 40 m 244812 50 m 269076
				MR-J3ENSCBL□M-L □=Cable length: 2, 5, 10, 20, 30 m ①	IP67	2 m 161567 5 m 161568 10 m 161569 20 m 161570 30 m 161571
⑩	Encoder connector set for HG-KR/HG-MR/HG-SR/HG-JR/HG-RR/HF-KN/HF-SN	Encoder connector (DDK) CM10-SP10S-M (straight plug) CM10-#225C(S1)-100 (socket contact)	Amplifier connector 36210-0100PL (receptacle, 3M) 36310-3200-008 (shell kit, 3M) oder 54599-1019 (connector set, Molex)	MR-J3SCNS	IP67	— 161576
						
		<Applicable cable example> Wire size: 0.5 mm ² (AWG20) or smaller Completed cable outer diameter: Ø 6.0 – 9.0 mm				

Note:
 ① -H and -L indicate a bending life. -H indicates a long bending life, and -L indicates a standard bending life.
 ② Concerning the making of the cables please refer to the user's manual of the servo amplifier MR-JE/MR-J4.

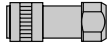
Select one for connecting the encoder to CN2

Item	Description	Model	Protection	Length	Art. no.	
Select one for connecting the encoder to CN2	<p>⑪ Encoder connector set for HG-KR/HG-MR/HG-SR/HG-JR/HG-RR</p>  <p><Applicable cable example> Wire size: 0.5 mm² (AWG20) oder kleiner Completed cable outer diameter: Ø 5.5 – 9.0 mm</p>	<p>Amplifier connector 36210-0100PL (receptacle, 3M) 36310-3200-008 (shell kit, 3M) oder 54599-1019 (connector set, Molex)</p> 	MR-ENCNS2	IP67	—	248686
	<p>⑫ Encoder connector set for HG-SR/HG-JR/HG-RR/HF-SN</p>  <p><Applicable cable example> Wire size: 0.5 mm² (AWG20) or smaller Completed cable outer diameter: Ø 5.5 – 9.0 mm</p>	<p>Amplifier connector 36210-0100PL (receptacle, 3M) 36310-3200-008 (shell kit, 3M) or 54599-1019 (connector set, Molex)</p> 	MR-J3SCNSA	IP67	—	227425
	<p>⑬</p>	<p>MR-ENCNS2A</p>	IP67	—	248687	
	<p>⑭ Encoder cable for HG-JR11K1M (4), 15K1M(4), 22K1M(4)</p> 	<p>Amplifier connector 36210-0100PL (receptacle, 3M) 36310-3200-008 (shell kit, 3M) or 54599-1019 (connector set, Molex)</p>	MR-ENECSBL□M-H-MTH □=Cable length 2, 5, 10, 20, 30, 40, 50 m	IP67	2 m 5 m 10 m 20 m 30 m	268160 268161 268162 268163 268164
	<p>⑮ Encoder connector set for HG-JR11K1M (4), 15K1M(4), 22K1M(4)</p>  <p><Applicable cable example> Wire size: 0.3 mm² (AWG22) to 1.25 mm² (AWG16) Completed cable outer diameter: Ø 6.8 – 10 mm</p>	<p>Amplifier connector 36210-0100PL (receptacle, 3M) 36310-3200-008 (shell kit, 3M) or 54599-1019 (connector set, Molex)</p> 	MR-ENECS	IP67	—	210966
	<p>⑯ Encoder connector set for TM-RFM</p> 	<p>Amplifier connector 36210-0100PL (receptacle, 3M) 36310-3200-008 (shell kit, 3M) or 54599-1019 (connector set, Molex)</p> 	MR-J3DDCNS	IP67	—	227979
	<p>⑰ Encoder connector set for TM-RFM</p> 	<p>Encoder connector RM15WTPZK-12P(72) (plug) JR13WCCA-8(72) (cable clamp)</p> 	MR-J3DDSPS	IP67	—	227980
	<p>⑱ Y cable for fully closed loop function</p> 	<p>Amplifier connector 36210-0100PL (receptacle, 3M) 36310-3200-008 (shell kit, 3M)</p>	MR-J4FCCBL03M	—	0.3 m	248690
	<p>⑲ Set for fully closed loop function</p> 	<p>Amplifier connector 36210-0100PL (receptacle, 3M) 36310-3200-008 (shell kit, 3M)</p> 	MR-J3THMCN2	—	—	227110

Item	Description	Model	Protection	Length	Art. no.	
Select one for the motor power supply	⑳ Power supply cable for HG-KR/HG-MR/HF-KN Lead out in direction of motor shaft, unshielded	MR-PWS1CBL□M-A1-H □=Cable length: 2, 5, 10 m ❶	IP65	2 m 5 m 10 m	160227 161592 161593	
	㉑ Power supply cable for HG-KR/HG-MR/HF-KN Lead out in opposite direction of motor shaft, unshielded	MR-PWS1CBL□M-A1-L □=Cable length: 2, 5, 10 m ❶	IP65	2 m 5 m 10 m	161594 161595 161596	
	㉒ Power supply cable for HG-KR/HG-MR/HF-KN Lead out in direction of motor shaft, shielded	MR-PWS1CBL□M-A2-H □=Cable length: 2, 5, 10 m ❶	IP65	2 m 5 m 10 m	160228 161597 161598	
	㉓ Power supply cable for HG-KR/HG-MR/HF-KN Lead out in opposite direction of motor shaft, shielded	MR-PWS1CBL□M-A2-L □=Cable length: 2, 5, 10 m ❶	IP65	2 m 5 m 10 m	161599 161600 161601	
	㉔ Power supply cable for HG-KR/HG-MR/HF-KN Lead out in direction of motor shaft, shielded, power chain.	MR-PWS3CBL□M-A1-L □=Cable length: 2, 5, 10 m ❶	IP65	2 m 5 m 10 m	210799 210800 210801	
	㉕ Power supply cable for HG-KR/HG-MR/HF-KN Lead out in opposite direction of motor shaft, shielded, power chain.	MR-PWS3CBL□M-A2-L □=Cable length: 2, 5, 10 m ❶	IP65	2 m 5 m 10 m	210802 210803 210814	
	㉖ Power supply cable for HG-KR/HG-MR/HF-KN Lead out in direction of motor shaft	PWS007N-□.0-A1 □=Cable length: 2, 5, 10 m	IP65	2 m 5 m 10 m	220009 220010 220012	
	㉗ Power supply cable for HG-KR/HG-MR/HF-KN Lead out in opposite direction of motor shaft	PWS007N-□.0-A2 □=Cable length: 2, 5, 10 m	IP65	2 m 5 m 10 m	220002 220005 220007	
	㉘ Power supply cable for HG-SR52/HF-SN52, HG-SR524-1524/HG-JR53-73/HG-JR534-1034	Motor power supply connector (Japan Aviation Electronics Industry) JN4FT04SJ1-R (connector) ST-TMH-S-C1B-100-(A534G) (socket contact)	MR-PWS2CBL03M-A1-L Cable length: 0.3 m ❶	IP55	0.3 m	161602
	㉙ Power supply cable for HF-SN102/HF-SN102, HG-JR103-203/HG-JR1534-3534	Motor power supply connector (DDK) CE05-6A□□SD-D-BSS (straight plug) CE3057-□A-□□-D (cable clamp)	MR-PWS2CBL03M-A2-L Cable length: 0.3 m ❶	IP55	0.3 m	161603
㉚ Power supply cable for HG-SR152/HF-SN152/HG-JR5034	PCS015N-□.0-0C4 □=Cable length: 2, 5, 10, 20, 30 m	IP67	2 m 5 m 10 m 20 m 30 m	202275 202276 202277 202278 202279		
㉛ Power supply cable for HG-SR2024	PCS025N-□.0-0C4 □=Cable length: 2, 5, 10, 20, 30 m	IP67	2 m 5 m 10 m 20 m 30 m	202280 202281 202282 202283 202294		
	PCS040N-□.0-0C4 □=Cable length: 2, 5, 10, 20, 30 m	IP67	2 m 5 m 10 m 20 m 30 m	202295 202296 202297 202298 202299		
	PCS025N-□.0-0C5 □=Cable length: 2, 5, 10, 20, 30 m	IP67	2 m 5 m 10 m 20 m 30 m	207465 207467 207468 207469 207470		

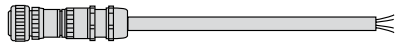
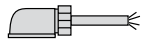
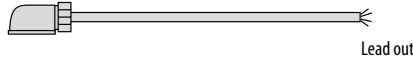



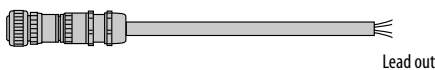

Notes:
 ❶ -H and -L indicate a bending life. -H indicates a long bending life, and -L indicates a standard bending life.
 ❷ The HG-RR motors with brake don't have an additional connector for brake. The contacts for brake are inside the power connector.

Item	Description	Model	Protection	Length	Art. no.	
Select one for the motor power supply	③② Power supply cable for HG-SR202/HG-SR3524/HG-JR353/HF-SN202	PCS040N-□-0-0C5 □=Cable length: 2, 5, 10, 20, 30 m	IP67	2 m 5 m 10 m 20 m 30 m	202300 202301 202302 202303 202304	
	③③ Power supply cable for HG-SR352-502/HG-SR5024/HG-JR503/HF-SN302	PCS060N-□-0-0C5 □=Cable length: 2, 5, 10, 20, 30 m	IP67	2 m 5 m 10 m 20 m 30 m	202468 202469 202470 202471 202472	
	③④ Power supply cable for HG-SR702/HG-SR7024	PCS100N-□-0-0C3 □=Cable length: 2, 5, 10, 20, 30 m	IP67	2 m 5 m 10 m 20 m 30 m	150771 150772 150819 150821 150822	
	③⑤ Power supply cable for HG-RR103-203	PCS040N-□-0-0C1 □=Cable length: 2, 5, 10, 20, 30 m	IP67	2 m 5 m 10 m 20 m 30 m	150734 150735 150737 150738 150739	
	③⑥ Power supply cable for HG-RR353-503	PCS060N-□-0-0C2 □=Cable length: 2, 5, 10, 20, 30 m	IP67	2 m 5 m 10 m 20 m 30 m	150757 150758 150760 150761 150762	
	③⑦ Power supply cable with integrated brake cable for HG-RR103B-203B ②	PCS040B-□-0-C1 □=Cable length: 2, 5, 10, 20, 30 m	IP67	2 m 5 m 10 m 20 m 30 m	150741 150742 150744 150745 150746	
	③⑧ Power supply cable with integrated brake cable for HG-RR353B-503B ②	PCS060B-□-0-C2 □=Cable length: 2, 5, 10, 20, 30 m	IP67	2 m 5 m 10 m 20 m 30 m	150764 150765 150766 150767 150768	
Motor power supply connectors	③⑨ Motor power supply connector set (motor side) for TM-RFM□C20/TM-RFM□E20	Motor power supply connector (DDK) CE05-6A14S-2SD-D (plug) (straight) YS014-9-11 (cable clamp) (Daiwa Dengyo) <Applicable cable example> Wire size: 0.3 mm ² (AWG22) to 1.25 mm ² (AWG16) Completed cable outer diameter: Ø 8.3 – 11.3 mm	MR-PWCNF (Straight type)	IP67	—	64037
	④⑩ Motor power supply connector set (motor side) for HG-SR52-152, HG-SR524-1524, HG-JR53-203, HG-JR534-2034, 3534 and 5034 TM-RFM_G20, HF-SN52J-152J	Motor power supply connector (DDK) CE05-6A18-10SD-D-BSS (plug) (straight) CE3057-10A-1-D (cable clamp) <Applicable cable example> Wire size: 2 mm ² (AWG14) to 3.5 mm ² (AWG12) Completed cable outer diameter: Ø 10.5 – 14.1 mm	MR-PWCNS4 (Straight type)	IP67	—	161573
	④⑪ Motor power supply connector set (motor side) for HG-SR202-502, HG-SR2024-5024, HG-JR353-503 TM-RFM040J10, TM-RFM120J10, HF-SN202J-302J	Motor power supply connector (DDK) CE05-6A22-22SD-D-BSS (plug) (straight) CE3057-12A-1-D (cable clamp) <Applicable cable example> Wire size: 5.5 mm ² (AWG10) to 8 mm ² (AWG8) Completed cable outer diameter: Ø 12.5 – 16 mm	MR-PWCNS5 (Straight type)	IP67	—	161574
	④⑫ Motor power supply connector set (motor side) for HG-SR702, 7024, HG-JR703-15K1M HG-JR7034-15K1M4 TM-RFM240J10	Motor power supply connector (DDK) CE05-6A32-17SD-D-BSS (plug) (straight) CE3057-20A-1-D (cable clamp) <Applicable cable example> Wire size: 14 mm ² (AWG6) to 22 mm ² (AWG4) Completed cable outer diameter: Ø 22 – 23.8 mm	MR-PWCNS3 (Straight type)	IP67	—	136358
	④⑬ Motor power supply connector set (motor side) for HG-RR103-203	Motor power supply connector (DDK) CE05-6A22-23SD-D-BSS (plug) (straight) CE3057-12A-2-D (cable clamp) <Applicable cable example> Wire size: 2 mm ² (AWG14) to 3.5 mm ² (AWG12) Completed cable outer diameter: Ø 9.5 – 13 mm	MR-PWCNS1 (Straight type)	IP67	—	64036
	④⑭ Motor power supply connector set (motor side) for HG-RR353-503	Motor power supply connector (DDK) CE05-6A24-10SD-D-BSS (plug) (straight) CE3057-16A-2-D (cable clamp) <Applicable cable example> Wire size: 5.5 mm ² (AWG10) to 8 mm ² (AWG8) Completed cable outer diameter: Ø 13 – 15.5 mm	MR-PWCNS2 (Straight type)	IP67	—	64035

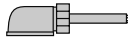

Notes:
 ① -H and -L indicate a bending life. -H indicates a long bending life, and -L indicates a standard bending life.
 ② The HG-RR motors with brake don't have an additional connector for brake. The contacts for brake are inside the power connector.

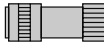









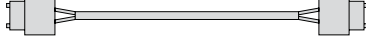
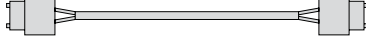
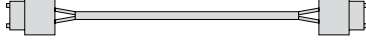

■ Cables and Connectors for Servo Amplifier (with electromagnetic brak)

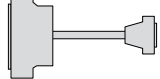
Item	Description	Model	Protection	Length	Art. no.		
④⑤	Brake cable for HG-KR/ HG-MR/HF-KN Lead out in direction of motor shaft	Motor power supply connector (Japan Aviation Electronics Industry) JN4FT04S1-R (plug) ST-TMH-S-C1B-100-(A534G) (socket contact)	MR-BKS1CBL□M-A1-H □=Cable length: 2, 5, 10 m ①	IP65	2 m 5 m 10 m	161604 161605 161606	
		MR-BKS1CBL□M-A1-L □=Cable length: 2, 5, 10 m ①	IP65	2 m 5 m 10 m	161607 161608 161609		
④⑥	Brake cable for r HG-KR/ HG-MR/HF-KN Lead out in opposite direc- tion of motor shaft	 Lead out	MR-BKS1CBL□M-A2-H □=Cable length: 2, 5, 10 m ①	IP65	2 m 5 m 10 m	160311 161610 161611	
			MR-BKS1CBL□M-A2-L □=Cable length: 2, 5, 10 m ①	IP65	2 m 5 m 10 m	161612 161613 161614	
④⑦	Brake cable for HF-KP/ HF-MP/HF-KE Lead out in direction of motor shaft	Motor power supply connector (Japan Aviation Electronics Industry) JN4FT04S1-R (plug) ST-TMH-S-C1B-100-(A534G) (socket contact)	MR-BKS2CBL03M-A1-L Cable length: 0.3 m ①	IP55	0.3 m	161615	
④⑧	Brake cable for HG-KR/ HG-MR/HF-KNE Lead out in opposite direc- tion of motor shaft	 Lead out	MR-BKS2CBL03M-A2-L Cable length: 0.3 m ①	IP55	0.3 m	161616	
Select one for the motor electro- magnetic brak	④⑨	Brake cable for HF-SN/ HG-SR/HG-JR Motor power supply connector (DDK) (soldered type) CM10-SP2S-L (straight plug), CM10-#22SC (S2)-100 (socket contact)		BCS015S-□0-BKS1 □=Cable length: 2, 5, 10, 20, 30 m	IP67	2 m 5 m 10 m 20 m 30 m	202249 202250 202251 202252 202253
	⑤⑩	Brake connector for HG-SR, HG-JR53B-903B HG-JR534B-9034B, HF-SN Motor power supply connector (DDK) (soldered type) CMV1-SP2S-L (straight plug), CMV1-#22BSC-S2-100 (socket contact)		MR-BKCN1 (Straight type)	IP67	—	161575
	⑤⑪	Brake connector for HG-SR, HG-JR53B-903B HG-JR534B-9034B <Applicable cable example> Wire size: 1.25 mm ² (AWG16) or smaller Completed cable outer diameter: Ø9.0 – 11.6 mm Motor power supply connector (DDK) (soldered type) CMV15-SP2S-L (straight plug), CMV1-#22BSC-S2-100 (socket contact)		MR-BKCN2 (Straight type)	IP67	—	248688
	⑤⑫	Brake connector for HG-SR, HG-JR53B-903B HG-JR534B-9034B, HF-SN Motor power supply connector (DDK) (soldered type) CMV1-AP2S-L (straight plug), CMV1-#22BSC-S2-100 (socket contact)		MR-BKCN1A	IP67	—	227427
	⑤⑬	Brake connector for HG-SR, HG-JR53B-903B HG-JR534B-9034B <Applicable cable example> Wire size: 1.25 mm ² (AWG16) or smaller Completed cable outer diameter: Ø9.0 – 11.6 mm Motor power supply connector (DDK) (soldered type) CMV15-AP2S-L (straight plug), CMV1-#22BSC-S2-100 (socket contact)		MR-BKCN2A	IP67	—	248689
	⑤⑭	Brake connector for HG-JR11K1MB, 15K1MB, 11K1M4B, 15K1M4B Motor power supply connector D/MS3106A10SL-4S(D190) (plug, DDK) YSO10-5 bis 8 (straight plug), Daiwa Dengyo) <Applicable cable example> Wire size: 0.3 mm ² (AWG22) to 1.25 mm ² (AWG16) Completed cable outer diameter: Ø5 – 8.3 mm		MR-BKCN (Straight type)	IP65	—	64034

Note:
① -H and -L indicate a bending life. -H indicates a long bending life, and -L indicates a standard bending life.

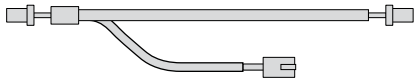

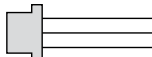
Encoder cables, battery connection relay cable, power supply cables, brake cables, USB cable and servo amplifier power supply connector set from ① to ⑤⑭ are same for the servo amplifier series MR-JE, MR-J4-A, MR-J4-B, MR-J4W2 and MR-J4W3.

■ Cables and Connectors for MR-J4 Servo Amplifier

Item	Description	Model	Protection	Length	Art. no.		
For CN1	⑤⑤ Connector set for MR-J4-A 	Amplifier connector (3M or an equivalent product) 10150-3000PE (connector) 10350-52F0-008 (shell kit)	MR-J3CN1	—	—	160225	
	⑤⑥ Cable of junction terminal block TB-50-EG and MR-J4-A 	Junction terminal block connector (3M) D7950-B500FL (connector) Amplifier connector (3M or an equivalent product) 10150-6000EL (connector) 10350-3210-000 (shell kit) ③	MR-J2M-CN1TBL□M□=	—	0.5 m 1 m	146794 189864	
For CN1A/ CN1B	⑤⑦ SSCNETIII/H cable (standard) for MR-J4-B MR-J4W2-B MR-J4W3-B 	Connector: PF-2D103 (Japan Aviation Electronics Industry)	MR-J3BUS□M	—	0.15 m 0.3 m 0.5 m 1 m 3 m	161579 161580 161581 161582 161583	
	⑤⑧ SSCNETIII/H cable (long flex) for MR-J4-B MR-J4W2-B MR-J4W3-B 	Connector: PF-2D103 (Japan Aviation Electronics Industry)	MR-J3BUS□M-A	—	5 m 10 m 20 m	161584 161585 161586	
	⑤⑨ SSCNETIII/H cable (long flex) for MR-J4-B MR-J4W2-B MR-J4W3-B 	Connector: PF-2D103 (Japan Aviation Electronics Industry)	MR-J3BUS□M-B	—	30 m 40 m 50 m	161587 161588 161589	
For CN3	⑥⑩ Connector set for MR-J4-B 		MR-J2CN1	—	—	55912	
	⑥⑪ Cable for junction terminal block TB-20-EG 	Amplifier connector (3M or an equivalent product) 10120-3000PE (connector) 10320-52F0-008 (shell kit) ③	Junction terminal block connector (3M) 3421-6020 (connector)	MR-J3TBL-CN3-□M-EG	—	0.5 m 1 m	212096 212095
	⑥⑫ Connector set (Qty:1 pc) for MR-J4W2-B MR-J4W3-B 	Amplifier connector (3M or an equivalent product) 10126-3000PE (connector) 10326-52F0-008 (shell kit)	MR-J2CMP2	—	—	149764	
	⑥⑬ Cable of junction terminal block TB-26-EG and MR-J4W2-B/MR-J4W3-B 	Amplifier connector (3M or an equivalent product) 10120-3000PE (connector) 10320-52F0-008 (shell kit) ③	Junction terminal block connector (3M) 3421-6020 (connector)	MR-ESTBL-CN1-□M-EG	—	0.5 m 1 m	215135 215137
For CN4	⑥⑭ Cable of battery MR-BT6VCASE and MR-J4W2-B/MR-J4W3-B 		MR-BT6V1CBL□M	—	0.3 m 1.0 m	248694 248695	
	⑥⑮ Cable for MR-J4W2-B and MR-J4W3-B 		MR-BT6V2CBL□M	—	0.3 m 1.0 m	248696 248697	
For CN5	⑥⑯ USB cable for MR-J4-B/ MR-J4-A/ MR-J4W2-B and MR-J4W3-B 	Amplifier connector mini B connector (5 pin) Personal computer connector A connector	MR-J3USBCBL3M	—	3 m	160229	
For CN6	⑥⑰ Monitor cable 		MR-J3CN6CBL1M	—	1 m	161578	
For CN8	⑥⑱ STO cable 	Safety logic unit connector (Tyco Electronics) 2013595-1 (connector set) Amplifier connector (Tyco Electronics) 2013595-1 (connector set)	MR-D05UDL3M-B	—	3 m	227986	

Note:
 ① -H and -L indicate a bending life. -H indicates a long bending life, and -L indicates a standard bending life.
 ② Concerning the making of the cables please refer to the user's manual of the servo amplifier MR-J4.
 ③ Connector and shell kit are press bonding type. The solder type is 10120-3000PE (connector) and 10350-52F0-008 (shell kit).

■ Cables and Connectors for MR-JE Servo Amplifier

Item	Description	Model	Protection	Length	Art. no.
For CN1	⑥⑨ Connector Set for MR-JE-A  Amplifier connector (3M or an equivalent product) 10150-3000PE (connector) 10350-52F0-008 (shell kit)	MR-J3CN1	—	—	160225
	⑦⑩ Cable of junction terminal block TB-50-EG and MR-JE-A  Amplifier connector (3M or an equivalent product) 10150-6000EL (connector) 10350-3210-000 (shell kit) ③ Junction terminal block connector (3M) D7950-B500FL (connector)	MR-J2M-CN1TBL□M □=Cable length: 0.5, 1m	—	0.5 m 1 m	146794 189864
For CN3	⑦① USB cable for MR-JE-A  Amplifier connector mini B connector (5 pin) Personal computer connector A connector	MR-J3USBCBL3M Cable length: 3 m	—	3 m	160229

Note:
 ① -H and -L indicate a bending life. -H indicates a long bending life, and -L indicates a standard bending life.
 ② Concerning the making of the cables please refer to the user's manual of the servo amplifier MR-J4.
 ③ Connector and shell kit are press bonding type. The solder type is 10120-3000PE (connector) and 10350-52F0-008 (shell kit).

■ Converter MR-ENCOM

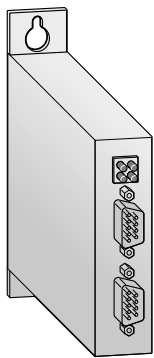

The interface module MR-ENCOM is a gateway to convert the Endat 2.2 or Hipecface DSL communication to Mitsubishi Electric serial encoder communication. By changing the external wiring the module is compatible to both Endat2.2 and Hyperface DSL.

In addition to the variety of compatible rotary/linear servo motors offered by Mitsubishi Electric, also motors from third-party manufacturers can be driven by MR-J4 servo amplifiers by using the gateway MR-ENCOM.

Specifications	MR-ENCOM-SET
Communication	Endat 2.1 (without analog signals and sense signal), Endat 2.2 (without safety function), Hyperface DSL (without safety function)
Absolute/incremental	Both
Rotary/linear	Both
Resolution	10–40 Bits
Rated output voltage	10 ±0.3 V (at CN1 connector)
Max. continuous output current	200 mA
Protection class	IP30
Dimensions (WxHxD)	mm 23x114x101
Order information	Art. no. 275133
Connection cables	Length 0.3 m; part of the set.
Servoamplifier	MR-J4-A-RJ and MR-J4-B-RJ (compatible with MR-ENCOM). Please contact your Mitsubishi Electric sales representative if necessary.

■ Buffer Battery

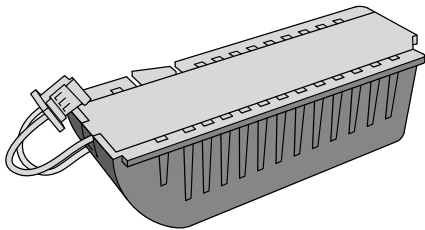

The servomotor's absolute value can be maintained by mounting the MR-BAT6V1SET battery on the servo amplifier. The battery is not required when the servo system is used in incremental mode.

Battery	Application
MR-BAT6V1SET	Buffering absolute positioning data
Order information	Art. no. 248691

■ Terminal Blocks

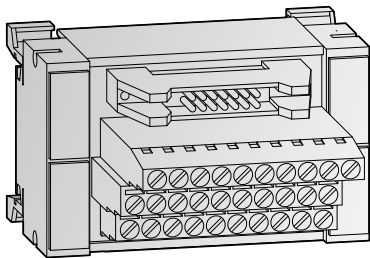

These terminal blocks TB-20-EG, TB-26-EG and TB-50-EG are adapter modules that simplify the wiring of the inputs and outputs of the servo

amplifiers. In addition preconfigured system cabling is available for all of these terminal blocks.

Specifications	TB-20-EG	TB-26-EG	TB-50-EG
Terminal block type	Input/output block	Input/output block	Input/output block
Channels	8/16	26	50
Design	20 pin terminal module	26 pin terminal module	50 pin terminal module
Connection type	Screw terminals	Screw terminals	Screw terminals
Application	Servoamplifier MR-J4-B	Servoamplifier MR-J4W2-B/ MR-J4W3-B	Servoamplifier MR-J4-A/ MR-JE-A Motion controller MR-MQ100, Q170MSCPU
Dimensions (WxHxD)	mm 75x45x52	73x81x58	102x81x80
Order information	Art. no. 212032	215134	212033
Connection cables	MR-J3TBL-CN3-05M-EG; length 0.5 m; Art. no.: 212096, MR-J3TBL-CN3-1M-EG; length 1 m; Art. no.: 212095	MR-ESTBL-CN1-05M-EG; length 0.5 m; Art. no.: 215135 MR-ESTBL-CN1-1M-EG; length 1 m; Art. no.: 215137	MR-J2M-CN1TBL05M; length 0.5 m; Art. no.: 146794 MR-J2M-CN1TBL1M; length 1 m; Art. no.: 189864

■ Manual Pulse Generator

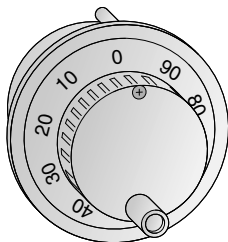

MR-HDP01

By this serial handwheel an external incremental setting value can be generated.

Specifications	MR-HDP01
Resolution	25 pls/rev (100 pls/rev at magnification of 4)
Output voltage	Input voltage > 1 V
Consumption current	Max. 60 mA
Weight	kg 0.4
Order information	Art. no. 128728

■ EMC Filters

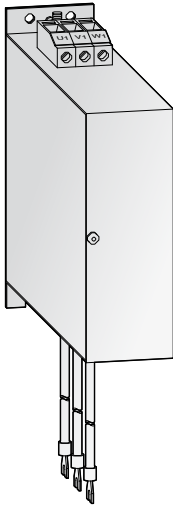

For complying with the EMC directives of the European Community regarding the electromagnetic compatibility, the servo amplifiers have to be equipped with a EMC filter across the input circuit. Additionally it has to be installed and wired according to the EMC directives.

The filter units are designed to reduce mains conducted RFI emissions to meet the European standard EN 61800-3.

More details are enclosed in the installation sheet of the MR-J4 filters.

Filter ^①	Servo amplifier	Power loss [W]	Rated current [A]	Leakage current [mA] ^②	Weight [kg]	Art. no.
MF-2F230-006.230MFa	MR-J4-10A/B–MR-J4-60A/B	10	6	<26	0.45	189332
MF-2F230-006.230MFb	MR-J4-70A/B	10	6	<26	0.45	189331
MF-2F230-006.232MF	MR-J4W2-22B–MR-J4W2-44B	2	6	<39	1.2	258685
MF-2F230-015.232MF	MR-J4W2-77B and MR-J4W3-222B–MR-J4W3-444B	4	15	<39	1.2	258261
MF-3F480-010.233MF	MR-J4-100A/B and MR-J4-60A4/B4 –MR-J4-100A4/B4	9	10	<7	1.0	208775
MF-3F480-015.230MF3	MR-J4-200A/B and MR-J4-200A4/B4	12	15	<4 ^②	1.5	200463
MF-3F480-015.234MF	MR-J4-350A4/B4	4	15	<11,7	1,5	270474
MF-3F480-025.230MF3 ^③	MR-J4-350A/B and MR-J4-500A4/B4 –MR-J4-700A4/B4	20	25	<4	3,0	203854
MF-3F480-050.230MF3 ^③	MR-J4-500A/B and MR-J4-700A/B	40	50	<4	4,0	203855
MF-3F480-015.232MF	MR-J4W2-1010B and MR-J4W3-222B–MR-J4W3-444B	4	15	<15	1.3	258268
FMR-ES-3A-RS1-FP	MR-JE-10A–MR-JE-40A	1	3	<3.5	0.32	219207
FMR-ES-6A-RS1-FP	MR-JE-70A	4.4	6	<3.5	0.37	219208

- ① All filters can provide conformity with the limits for environment 1, restricted distribution up to 50 m or environment 1, unrestricted distribution up to 20 m.
- ② At normal operation: voltage difference between 2 phases < 3 %/at fault occurrence (value in brackets) : 2 dead phases (worst case)
- ③ No foot print filter

■ Brake Resistors

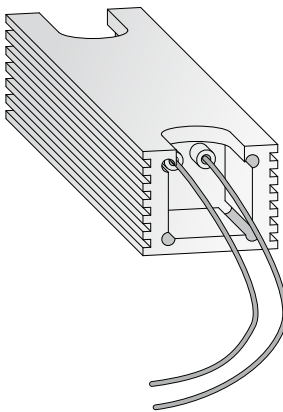

If the regenerative power exceeds the power of the built-in resistor, the following listed optional brake resistors can be used.

Resistor	Servo amplifier	Power capacity [W]	Resistance [Ω]	Weight [kg]	Dimensions (WxHxD) [mm]	Art. no.
MR-RFH75-40	MR-J4-10A/B–MR-J4-100A/B, and MR-JE-10A–MR-JE-100A	150	40	0.16	36x27x90	137279
MR-RFH220-40	MR-J4-70A/B–MR-J4-100A/B and MR-JE-70A–MR-JE-100A	400	40	0.42	36x27x200	137278
MR-RFH400-13	MR-J4-200A/B and MR-JE-200A–MR-JE-300A	600	13	0.73	36x27x320	137277
MR-RFH400-6.7	MR-J4-500A/B–MR-J4-700A/B	600	6.7	0.73	36x27x320	137275
MR-PWR-RT 400-120	MR-J4-60A4/B4–MR-J4-100A4/B4	400	120	0.4	36x27x200	154746
MR-PWR-RT 600-26	MR-J4-500A4/B4–MR-J4-700A4/B4, MR-J4W2-22B–MR-J4W2-44B and MR-J4W3-222B–MR-J4W3-444B	600	26	0.64	36x27x320	154752
MR-PWR-RT 600-9	MR-J4W2-77B–MR-J4W2-1010B and MR-J4-350A/B	400	9	0.64	36x27x320	269425
MR-PWR-RT 600-47	MR-J4-200A4/B4–MR-J4-350A4/B4	600	47	0.64	36x27x320	154751

Note: The MR-J4-11KA4/B4–MR-J4-22KA4/B4 have the external brake resistors included.

■ Setup Software (MR Configurator2)

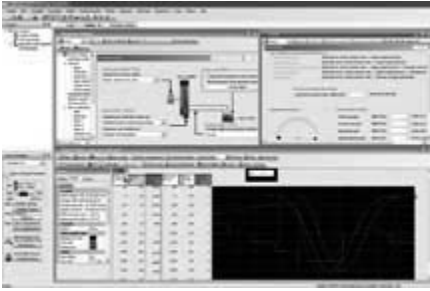

The comfortable setup software for Windows based personal computers allows perfect tuning of the servo amplifiers and the connected servo motors.

The software makes it easy to read and write parameters, monitor, diagnose and test the servo system via a personal computer.

Functions	MR Configurator2
Monitor	Batch display, input/output I/F display, high speed monitor, graph display
Parameters	Parameter setting, device setting, tuning, display of change list, display of detailed information, converter, parameter copy
Diagnostics	Rotation failure reason display, system information display, tuning data display, absolute data display, axis name setting, amplifier diagnostic
Alarms	Alarms Alarm display, alarm history, display of data that generated alarm
Test operations	JOG operation, positioning operation, operation without motor, forced digital output, program operation using simple language
Advanced function	Advanced function Machine analyser, gain search, machine simulation
Others	Others Automatic operation, help display, project and data administration
Order information	Art. no. 251540

■ G-CAD Converter Software



The G-CAD converter software enables the import of 2D CAD files and G code programs and converts these into programs processable with Simple Motion/Motion Controllers.

The process profile can be edited and optimized before transfer.

With the help of the G-CAD converter software the user can arrange different process profiles quick and easily, without touching the PLC program.



Functions	G-CAD Converter
Data import	DXF file and G code program as text file
Data transfer	Direct positioning data transmission to Simple Motion modules
Data export	Positioning data export to a CSV file
Others	Automatic shortcut of single elements, shifting an rotation possible, move sequence changing
Supported languages	English, German, Italian, Polish, Turkish
Supported devices	FX3U-20SSC-H, LD77MS, QD75MH, QD77MS

MELSEC FX Positioning Units

The high-speed counter and single axis positioning modules described below can be used in combination with the FX series PLCs.

This provides a cost effective solution for small servo/motion applications.

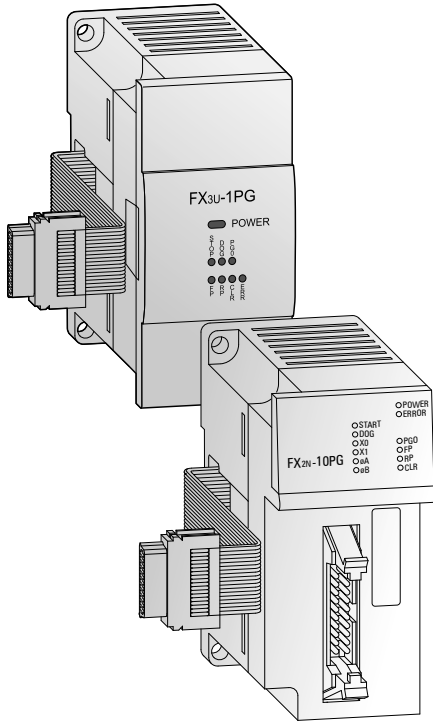

High speed counter and pulse train modules

These high speed modules provide additional counting and pulse train output features to the FX3U/FX3UC PLC. The high speed counters allow 1- or 2-phase pulses with counting speeds up to a maximum of 50 kHz for the FX2N-1HC and 200 kHz for the FX3U modules.

The FX3U-2HSY-ADP pulse train output module can provide pulse streams up to 200 kHz for use in basic positioning applications.

The MR-JE-A and MR-J4-A series amplifiers can be directly driven by these units.

Single-axis positioning module

The positioning modules FX3U-1PG and FX2N-10PG are extremely efficient single-axis positioning modules for controlling servo drives like MR-JE-A and MR-J4-A, (by external controller) with a pulse train. It is very suitable for achieving accurate positioning in combination with the MELSEC FX series.

The configuration and allocation of the position data are carried out directly via the PLC program.

A very wide range of manual and automatic functions are available to the user.

Specifications	FX3U-1PG	FX2N-10PG
Accessible axes	1	1
Output frequency pulse/s	10–100 000	1–1 000 000
Signal level for digital inputs	24 V DC/40 mA	5 V DC/100 mA; 24 V DC/70 mA
Power supply	5 V DC 24 V DC	55 mA (from base unit) —
Related I/O points	8	8
Dimensions (WxHxD)	mm 43x90x87	43x90x87
Order information	Art. no. 259298	140113

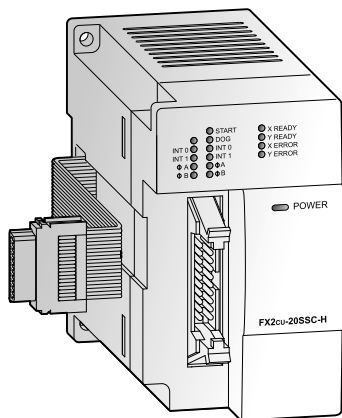

SSCNETIII module FX3U-20SSC-H

The SSCNET module FX3U-20SSC-H can be used in combination with a FX3U programmable controller to achieve a cost effective solution for high precision, high speed positioning. The plug-and-play fiber optic SSCNETIII cabling reduces setup time and increases control distance for positioning operations in a wide range of applications.

Servo parameters and positioning information for the FX3U-20SSC-H are easily set up with an FX3U base unit and a personal computer. For parameter setting, monitoring and testing the easy programming software FX Configurator-PP is available.

For further specifications please refer to the MELSEC FX technical catalogue.

Specifications	FX3U-20SSC-H
Accessible axes	2 (independent or interpolation) via SSCNETIII
Output frequency	1 Hz b to 50 MHz
Communications speed	50 Mbps
Starting time ms	1.6 (+1.7 SSCNETIII cycle time)
Max. to PLC connectable modules	Up to 8 can be connected to the FX3U PLC
Power supply	5 V DC 24 V DC
Related I/O points	8
Dimensions (WxHxD)	mm 55x90x87
Order information	Art. no. 231512

Note: The FX3U-20SSC-H can only be used in combination with a FX3U series base unit.

MELSEC System Q Positioning Units

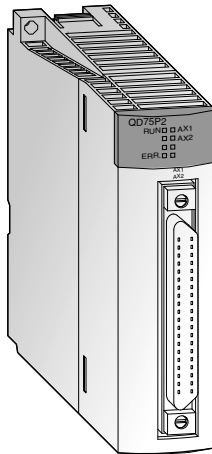

The MELSEC System Q offers two different positioning module series for control of up to four axes:

- Open-collector output type (QD75P series)
- Differential output type (QD75D series)

The open-collector and differential output controllers can be used with standard type servo amplifiers (MR-JE-A/MR-J4-A).

All QD75 series positioning modules can provide functionality such as interpolation and speed-position operation etc.

The open-collector output type modules provide positioning with open loop control. The modules generate the travel command via the pulse chain. The speed is proportional to the pulse frequency and the distance travelled is proportional to the pulse length.

The differential output type modules are suitable for bridging long distances between the module and the drive system due to the fact that the output allows large motor cable lengths.

Specifications	QD75D1	QD75D2	QD75D4	QD75P1	QD75P2	QD75P4
Number of control axes	1	2	4	1	2	4
Interpolation	—	2 axes linear and circular interpolation	2, 3, or 4 axes linear and 2 axes circular interpolation	—	2 axes linear and circular interpolation	2, 3, or 4 axes linear and 2 axes circular interpolation
Positioning data items	600					
Output type	Differential driver	Differential driver	Differential driver	Open collector	Open collector	Open collector
Output signal	Pulse chain	Pulse chain	Pulse chain	Pulse chain	Pulse chain	Pulse chain
Positioning	PTP control: absolute data and/or incremental; speed/position switching control: incremental; locus/speed control: incremental; path control: absolute data and/or incremental					
	Absolute data:		Incremental method:		Speed/position switching control:	
	-2 147 483 648 – 2 147 483 647 pulse		-2 147 483 648 – 2 147 483 647 pulse		0 – 2 147 483 647 pulse	
	-214 748 364.8 – 214 748 364.7 μm		-214 748 364.8 – 214 748 364.7 μm		0 – 21 474 836.7 μm	
	-21 474.83648 – 21 474.83647 inch 0 – 35.99999 degree		-21 474.83648 – 21 474.83647 inch -21 474.83648 – 21 474.83647 degree		0 – 21 474.83647 inch 0 – 21 474.83647 degree	
speed	1 – 1 000 000 pulse/s 0.01 – 20 000 000.00 mm/min 0.001 – 200 000.000 degree/min 0.001 – 200 000.000 inch/min					
acceleration/deceleration processing	Automatic trapezoidal or S-pattern acceleration and deceleration or automatic S-pattern acceleration and deceleration					
acceleration and deceleration time	1–8388608 ms (4 patterns, each can be set)					
rapid stop deceleration time	1–8388608 ms					
I/O points	32	32	32	32	32	32
Dimensions (WxHxD)	mm 27.4x98x90	27.4x98x90	27.4x98x90	27.4x98x90	27.4x98x90	27.4x98x90
Order information	Art. no. 129675	132581	129676	132582	129677	132583
Accessories	40-pin connector and ready to use connection cables and system terminals; Programming software: GX Configurator QP, art. no.: 132219					

MELSEC L Series Positioning Units

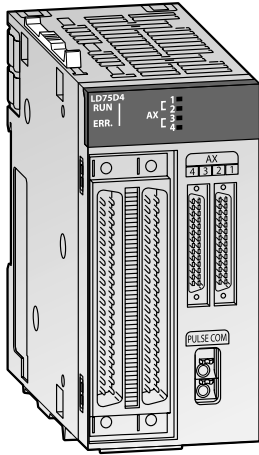

Control of high resolution drives

The MELSEC L series offers two different positioning modules for control of up to four axes.

- Differential output type (LD75D□)
- Open-collector output type (LD75P□)

These positioning modules can be used with standard type servo amplifiers (Mitsubishi Electric MR-JE-A, MR-J4-A).

All MELSEC L series positioning modules can provide functionality such as interpolation, speed positioning operation etc.

The open-collector output type module provides positioning with open loop control. The module generates the travel command via the pulse chain. The speed is proportional to the pulse frequency and the distance travelled is proportional to the pulse length.

The differential output type module is suitable for bridging long distances between the module and the drive system due to the fact that the output allows large cable lengths.

- Up to 600 positioning data per axis
- Maximum output pulse of 200 k pulses/s for LD75P4 and 4 Mpulses/s for LD75D4)
- High speed control of high resolution devices such as linear servos and direct drive motors
- Reduced machine vibration by using the optional acceleration/deceleration system
- Visualization of positioning module buffer data with customizable graphs

Specifications	LD75D1	LD75D2	LD75D4	LD75P1	LD75P2	LD75P4	
Accessible axes	1	2	4	1	2	4	
Output frequency	—	2-axis linear interpolation, 2-axis circular interpolation	2-/3-/4-axis linear interpolation, 2-axis circular interpolation	—	2-axis linear interpolation, 2-axis circular interpolation	2-/3-/4-axis linear interpolation, 2-axis circular interpolation	
Positioning data items per axis	600						
Output type	Differential driver			Open collector			
Output signal	Pulse chain						
Positioning	method	PTP (Point To Point) control, path control (both linear and arc can be set), speed control, speed-position switching control, position-speed switching control					
	range	Absolute/incremental system: -214 748 364.8–214 748 364.7 μm -21 474.83648–21 474.83647 inch 0–359.99999 degree (absolute); 21 474.83648–21 474.83647 (incremental) -2 147 483 648–2 147 483 647 pulse					
	speed	In speed-position switching control (INC mode)/position-speed switching control: 0–214 748 364.7 μm 0–21 474.83647 inch 0–21 474.83647 degree 0–2 147 483 647 pulse					
	acceleration/ deceleration processing	Automatic trapezoidal or S-pattern acceleration and deceleration or automatic S-pattern acceleration and deceleration					
	acceleration/ deceleration time	1–83 88 608 ms (four patterns can be set for each of acceleration time and deceleration time)					
	rapid stop deceleration time	1–8 388 608 ms					
Number of occupied I/O points	32	32	32	32	32	32	
Internal current consumption	510 mA	620	760	440	480	550	
Dimensions (WxHxD)	45x90x95 mm	45x90x95	45x90x95	45x90x95	45x90x95	45x90x95	
Order information	Art. no.	251448	251449	238095	251446	251447	238096

MELSEC Simple Motion module

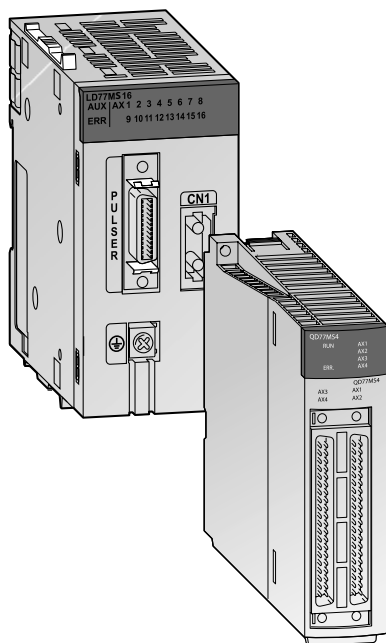

The MELSEC System Q and MELSEC L series lineup includes Simple Motion modules in addition to the regular positioning modules. Various control functions previously only possible with Motion Controllers, such as speed control, torque control, synchronous control and cam control, are now available with the Simple Motion modules. These functions can be realized with simple parameter adjustments and via the PLC program.

Mark sensors allow use in packaging industry, filling plants, etc., without additional optional modules. A function for automatic calculation of cam data for applications with rotating cutters is implemented – only by setting the length of the product and the synchronisation path. With positioning functions, like linear interpolation (up to 4 axes), circular interpolation (2 axes) and path control it is easy to realize different applications, like X-Y tables, sealing, etc.

Proved and tested programs for the QD77MS and the LD77MS are compatible with the QD75MH.

- Compatible with QD75MH
- Up to 600 positions per axis
- External encoder input for axis synchronisation
- Electronic cam control
- High-speed digital inputs for mark sensors to capture encoder position, motor position etc.
- Parameterization, programming, diagnostics and test operation by GX Works2
- Certified PLCopen function blocks
- Communication between the Simple Motion module and servo amplifiers via the high-speed network SSCNETIII/SSCNETIII/H



Specifications		LD77MS2	LD77MS4	LD77MS16	QD77MS2	QD77MS4	QD77MS16	
Number of controllable axes		2	4	16	2	4	16	
Interpolation functions		2 axes linear and circular interpolation	Linear interpolation for up to 4 axes, circular interpolation for 2 axes		2 axes linear and circular interpolation	Linear interpolation for up to 4 axes, circular interpolation for 2 axes		
Output type		SSCNETIII/H	SSCNETIII/H	SSCNETIII/H	SSCNETIII/H	SSCNETIII/H	SSCNETIII/H	
Output signal		Bus	Bus	Bus	Bus	Bus	Bus	
Servo amplifier		MR-J3-BSafety over SSCNETIII, MR-J4-B over SSCNETIII/H						
Operation cycle		0.88 ms	0.88 ms	0.88 ms/1.7 ms	0.88 ms	0.88 ms	0.88 ms/1.7 ms	
Positioning	method	PTP (Point To Point) control, path control (linear and arc), speed control, speed-position switching control, position-speed switching control, torque control						
	acceleration/deceleration control	Trapezoidal acceleration/deceleration, S-curve acceleration/deceleration						
	compensation	Backlash compensation, electronic gear, near pass function						
	OPR control	5 different methods						
Number of positioning points		600 per axis (can be set with GX Works2 or PLC program)						
External input signals	encoder	1 encoder, A/B phase						
	high speed inputs	4 digital inputs [DI1–DI4]						
Cam function	storage area cam data	256 kbytes						
	number of cams	Max. 256 (depends on resolution)						
	resolution per cycle	256, 512, 1024, 2048, 4096, 8192, 16384, 32768						
	stroke resolution	2–16284						
I/O points	32	32	32	32	32	32	32	
Dimensions (WxHxD)	mm	90x45x95	90x45x95	90x45x95	27.4x98x90	27.4x98x90	27.4x98x90	
Order information		Art. no.	268199	268200	268201	248702	248703	248704

■ Single Axis Motion Controller MR-MQ100

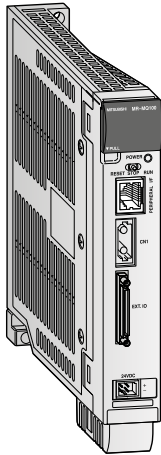

The MR-MQ100 allows a single axis to be completely controlled and synchronised to a separate encoder or virtual axis with no additional controller hardware like a PLC. Applications such as rotary cutters, flying saws and labelling can be realized cost-effectively. A complete range of essential functions are available, including encoder and virtual axis synchronization, registration, point to point positioning and user defined cam profiles. In addition, the hardware complements these powerful software features with built-in I/O and SSCNETIII motion networking capability as well as an Ethernet port.

The MR-MQ100 uses Mitsubishi's simple but rugged optical fiber motion network SSCNETIII. A single fiber connection is all that's needed to provide full communication and control over all functions of the MR-J4/MR-J3-BSafety servo amplifier regardless of capacity.

- A standard Ethernet connection is also provided to link the MR-MQ100 to the MT Works2 software and to the control system.
- Stand-alone Motion Control System only with servo amplifier without additional hardware
 - Optical high-speed SSCNETIII network
 - Ethernet interface 100/10 Mbps
 - High speed inputs for mark sensors
 - External encoder input for axis synchronization
 - MC protocol Ethernet communication
 - Extension I/O unit MR-J3-D01 can be connected to the MR-J3-BSafety amplifier series to increase the number of in- and outputs
 - Integrated serial interface (RS422) for communication with HMI

Items	MR-MQ100	
Power supply	24 V DC ±10 % (required current capacity: 400 mA)	
Digital inputs (mark sensors)	4 inputs (24 V DC)	
Digital outputs	2 outputs (24 V DC)	
Synchronous encoder	signal type	A/B phase pulse train input
	voltage input/open-collector type (5 V DC)	Up to 800 kpps (after magnification by 4), up to 10 m
	differential input type	Up to 4 Mpps (after magnification by 4), up to 30 m
Peripheral interface	100 Mbps/10 Mbps Ethernet (for programming and additional options)	
Positioning	method	(PTP (Point to Point) control, Speed control/Speed-position control, Fixed-pitch feed, Constant speed control, Position follow-up control, Speed control with fixed position stop, Speed switching control, High-speed oscillation control, Synchronous control (SV22))
	acceleration/deceleration control	Automatic trapezoidal acceleration/deceleration, S-curve acceleration/deceleration
	compensation	Backlash compensation, Electronic gear, Phase compensation
Servo program capacity	16 k steps	
Number of positioning points	3200	
Number of control axis	1 axis	
Operation cycle	0.44 ms	
Servo amplifier	MR-J3-BSafety/MR-J4-B (over SSCNETIII)	
Programming language	Motion SFC, dedicated instruction, mechanical support language (SV22)	
Memory back up (included)	Q6BAT	
Cam function	number of cams	Up to 256 cam profiles may be stored internally.
	resolution per cycle	256, 512, 1024, 2048
	stroke resolution	32767
	control mode	Two-way cam, feed cam
Weight [kg]	0.7	
Dimensions (WxHxD)	mm 30x168x135 ^①	
Order information	Art. no. 217705	

① H without battery (Height with battery = 178 mm)

Accessories	Q170MCPUI-EXTIO-05M-EG	Q170MCPUI-EXTIO-1M-EG	Q170MCPUI-EXTIO-3M
Application	Cable between Q170MCPUI IO I/F and TB-50-EG	Cable between Q170MCPUI IO I/F and TB-50-EG	Cable for Q170MCPUI IO I/F with open ends
Length	m 0.5	1	3
Order information	Art. no. 229275	229276	229277

■ Stand-alone Motion Controller Q170MSCPU/Q170MSCPU-S1

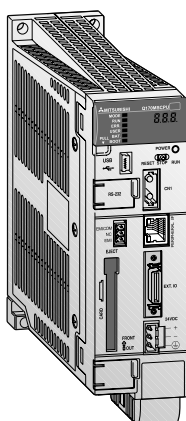

The Q170MSCPU/Q170MSCPU-S1 combines a PLC CPU, a Motion CPU and a power supply module into one compact unit. No base unit is required, although an extension base unit with standard PLC modules can be connected if required. An encoder interface is included as standard, enabling multiple axes synchronization with an external encoder.

The well-reputed mechanical support language (SV13, SV22) from the MELSEC System Q Motion Controller is incorporated.

- Small size
- Controls up to 16 axes
- Communication with servo amplifier via high-speed network SSCNETIII/H and a communication speed up to 150 Mbps.
- Programming and configuration is performed using the familiar software GX Works2 and MT Works2.
- Expandable with an extension base unit (up to 5 slots) and I/O modules, intelligent modules, and network-related modules.
- MC protocol Ethernet communication

Specifications		Q170MSCPU	Q170MSCPU-S1
Motion-CPU	number of controllable axes	16	
	operation cycle	0.22 ms, 0.44 ms, 0.88 ms, 1.77 ms, 3.55 ms, 7.11 ms	
	programming languages	Motion SFC, dedicated instruction, mechanical support language (SV22)	
	servo program capacity	16 k steps	
	servo amplifier	MR-J3-BSafety over SSCNETIII, MR-J4-B over SSCNETIII/H	
Interpolation functions		Linear interpolation for up to 4 axes, circular interpolation for 2 axes, helical interpolation for 3 axes	
PLC CPU	number of I/O points	4096 points	
	programming languages	Ladder, instruction list, SFC, structured text	
	program capacity	30 k steps (120 k bytes)	60 k steps (240 k bytes)
	processing speed	20 ns (LD instruction); 40 ns (MOV instruction)	9.5 ns (LD instruction); 19 ns (MOV instruction)
total number of instructions		858 (including real number operation instruction)	
Positioning	method	(PTP (Point To Point) control, speed control/speed-position control, fixed-pitch feed, constant speed control, position follow-up control, speed control with fixed position stop, speed switching control, high-speed oscillation control, synchronous control (SV22))	
	acceleration/deceleration control compensation	Automatic trapezoidal acceleration/deceleration, S-curve acceleration/deceleration	
Memory card interface		Backlash compensation, electronic gear, phase compensation	
Memory card interface		1 slot for memory card for MELSEC System Q	
Cam function	number of cams	Up to 256 cam profiles may be stored internally.	
	resolution per cycle	256, 512, 1024, 2048, 4096, 8192, 16384, 32768	
	stroke ratio data	-2147483648 to 2147483647	
control mode		Two-way cam, feed cam	
Dimensions (WxHxD)		mm 52x178x135	
Order information		Art. no. 266524	266535

MELSEC System Q Motion-Controller-CPUs

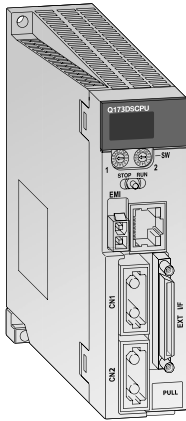

The Q-Motion controller CPU controls and synchronises the connected servo amplifiers and servo motors. A motion system besides the controller CPU, also includes a PLC CPU. Only after combining a highly dynamic positioning control CPU and a PLC, an innovative motion control system is created.

While the Motion CPU controls large-scale servo movements the PLC CPU is responsible for the machine control and the communication.

- Using multiple CPUs to distribute the load improves the overall performance of the whole system
- Use of up to 3 motion CPUs within one system
- Large scale control system for up to 96 axes per system
- Interpolation of 4 axes simultaneously
- Electronic cam control
- Virtual and real master axes
- Integration in the high-speed SSCNETIII/H network for communication with high-performance MR-J4-B servo amplifiers at up to 150 Mbps

4

Specifications	Q172DSCPU	Q173DSCPU
Type	Motion CPU	Motion CPU
I/O points	8192	8192
No. of control axes	16	32
Interpolation functions	Linear interpolation for up to 4 axes, circular interpolation for 2 axes, helical interpolation for 3 axes	
Positioning	method PTP (point to point), speed control/speed-position control, fixed pitch feed, constant speed control, position follow-up control, speed switching control, high-speed oscillation control, synchronous control (SV22)	
	acceleration/deceleration control Automatic trapezoidal acceleration/deceleration, S-curve acceleration/deceleration	
	Backlash compensation, electronic gear	
Programming language	Motion SFC, dedicated instructions, software for conveyor assembly (SV13), virtual mechanical support language (SV22)	
Servo program capacity	16 k steps	
No. of positioning points	3200	
Interfaces	Ethernet 100 Mbps/10 Mbps (for programming and additional options), SSCNETIII/H (for connection to servo amplifier with optical cable) (USB, RS232C via PLC-CPU)	
Servo amplifier	MR-J3-BSafety over SSCNETIII/ MR-J4-B over SSCNETIII/H	
Dimensions (WxHxD)	mm 27.4x120.5x120.3	27.4x120.5x120.3
Order information	Art. no. 248700	248701

MELSEC System Q Motion System Modules

Servo external signals interface module Q172DLX

The Q172DLX input module is used in conjunction with a Q Motion CPU to capture external servo signals.

Up to 8 axes can be evaluated per module. In this way, proximity dog sensor, upper/lower limit switch, stop signal input and operating mode switching input can be easily incorporated into the system.

- 32 address points for 8 axes for each 4 inputs
- Bipolar inputs for positive and negative logic
- Galvanic isolation of the inputs by means of photocoupler
- Shortest response time of < 0.4 ms
- Modular extension possible

Serial absolute synchronous encoder interface module Q172DEX

The serial absolute synchronous encoder interface module Q172DEX is a Motion system module for receiving and evaluating up to two serial absolute-value encoders (Incremental

encoders cannot be connected). Via an external encoder it is possible to feed a setpoint source to the Motion system, which in turn is programmed as a master axis.

In addition to the interfaces for the signals of two absolute-value encoders, the Q172DEX has two digital inputs with ultra-rapid responsetimes.

- Transfer rate of 2.5 Mbit per second
- Resolution of 22 Bit with Q170ENC-WB
- Voltage-failure security of the absolute values by means of built-in buffer battery
- Shortest response times of < 0.4 ms
- Modular extension possible

Manual pulse generator interface module Q173DPX

The Manual pulse generator interface module is used in a Motion system to receive the signals of up to 3 external incremental encoders or manual impulse generators (hand wheels).

In addition to the inputs for the encoders, the Q173DPX has three digital inputs with which the encoder signal counting procedure can be started (Encoder start signal).

- Bipolar inputs for positive and negative logic
- Galvanic isolation of the inputs by means of photo coupler
- Shortest response times of < 0.4 ms
- Modular extension possible

Safety signal module Q173DSXY

The safety signal module is a combined I/O extension module with 20 safety input points x 2 paths and 12 safety output points x 2 paths. It passes input and output informations on to a Motion CPU or PLC CPU module.

With its safety monitor function the system fulfils the requirements of the following safety functions: STO, SS1, SS2, SOS, SLS, SBC, SSM (IEC61800-5-2:2007)

Configuration of a SSCNETIII/H System

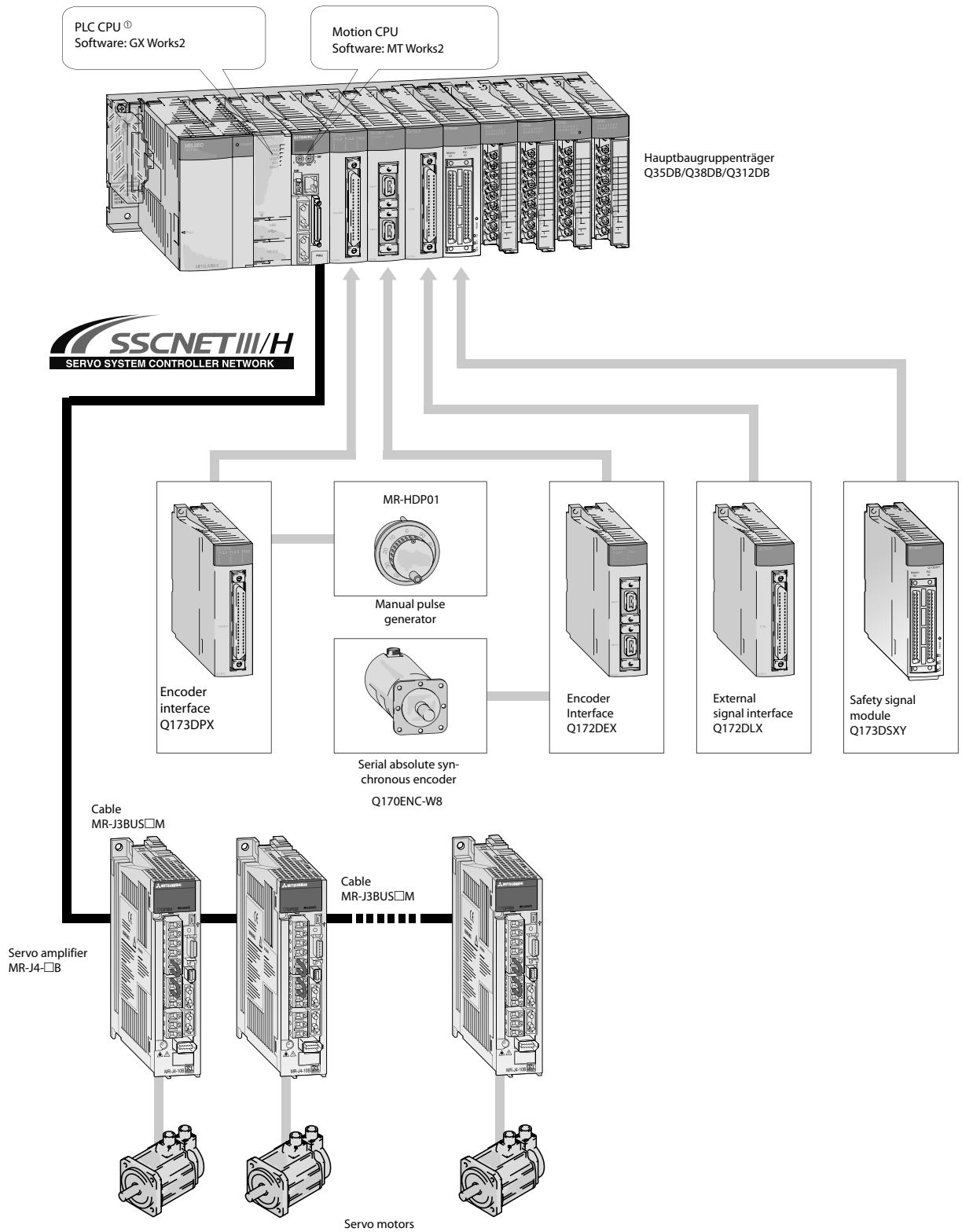

Note:

- ① The first CPU on the main base unit must always be a PLC CPU (e.g. Q□UD(E)(H) Serie)

X-Y Table System Configurations

An X-Y table is a typical two axes servo application, commonly used in industry for pick and place systems such as PCB component insertion machines through to welding machines.

The following information provides two examples of possible X-Y table system configurations, using Mitsubishi Electric automation equipment.

The first is a FX3G-24MT/ESS based system and the second is a more complex interpolating QD77MS2 (SSCNETIII/H) based system.

System 1: FX3G PLC based system

Products	Function
FX3G-24MT/ESS	PLC with integrated positioning control
MR-E-10A-QW003	Servo amplifier
HF-KN13	Motor
MR-E-70A-QW003	Servo amplifier
HF-SN52JK	Motor

The FX3G is a compact PLC for comprehensive machine control. It combines the functions of a PLC with positioning functions. In this configuration the FX3G-24MT/ESS is used to control the

X and Y axes. Via the transistor open collector outputs the PLC provides the Servo amplifiers of the MR-JE-A Series with pulse train signals for controlling the two axes. The setting of the system can be done with the GX Works2.

GX Works2 has a special section for the general positioning parameter setup and for the setup of each positioning command in a easy to use table. This table for each axis can contain 100 instructions with the frequency and number of pulses stored in the user data area and can be manipulated and uploaded for setting into operation of the machine.

For expanding the system, the FX3G is also connectable to the majority of existing FX3U Special Function Blocs.

- User friendly positioning
- Easy setting in GX Works2
- Cost effective
- Simple functionality

System 2: QD77MS based system

Products	Function
Q00J	PLC of MELSEC System Q
QD77MS2	Simple motion modul
MR-J4-10B	Servo amplifier
HG-KR13	Motor
MR-J4-60B	Servo amplifier
HG-SR52	Motor
MR-BAT6V1SET	Battery (for servo amplifier)

The QD77MS based system uses the powerful modular Qn PLC Series, providing greater functionality and expandability options. The QD77MS system is connected using SSCNETIII/H (Servo System Controller Network), which is Mitsubishi's dedicated motion control network. SSCNETIII/H simplifies the set-up of the system and reduces the wiring required. SSCNETIII/H systems are created by simply plugging an amplifier into the main controller (QD77MS) and then "daisy-chaining" each additional axis that is added. SSCNETIII/H connectivity requires MR-J4-B type amplifiers to be used.

Furthermore, as the Servo amplifiers are connected by a bus system, all Servo data, such as current position, torque etc. can all be monitored back at the main controller (Q00J PLC) as the data is automatically updated on the QD77MS module.

Also, all of the internal Servo parameters can be set from the PLC, again due to the bus system used.

The bus system also means that position data is sent serially, therefore reducing any possible interference due to noise.

Finally, as both axes are controlled from one high function module (QD77MS), interpolation between the two axes is possible.

- SSCNETIII/H capability
- Easy of set-up
- High functionality
- Expandability
- Module options
- Reduced wiring

X-Y table control

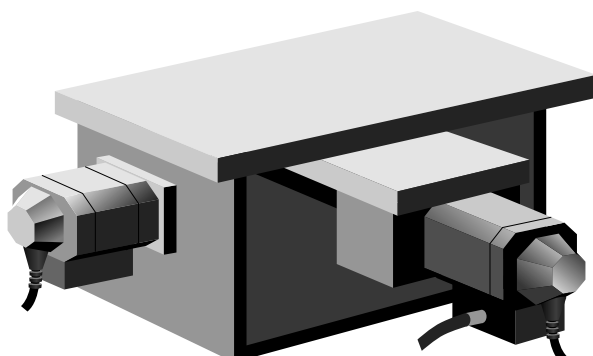

Servo Motors

HG-KR053(B), HG-KR13(B), HG-MR053(B), HG-MR13(B)

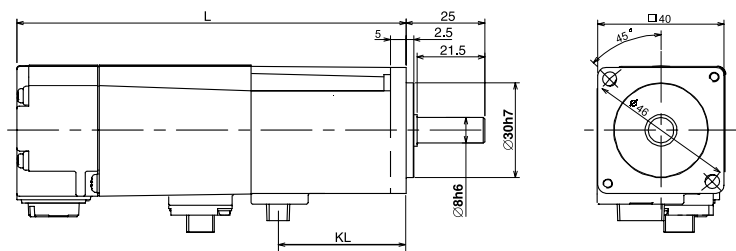

Type	L [mm]	KL [mm]
HG-KR053(B) HG-MR053(B)	66.4 (107)	23.8
HG-KR13(B) HG-MR13(B)	82.4 (123)	39.8

Dimensions for motors with brake in brackets ().

Unit: mm

HG-KR23(B), HG-KR43(B), HG-MR23(B), HG-MR43(B)

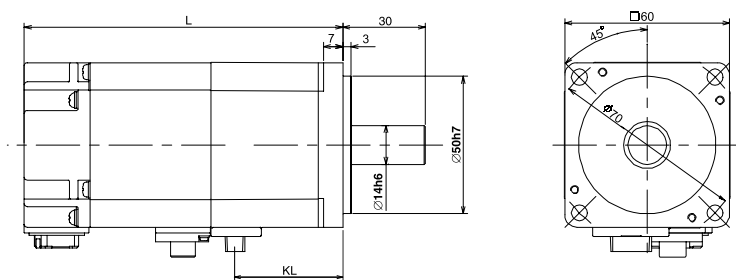

Type	L [mm]	KL [mm]
HG-KR23(B) HG-MR23(B)	76.6 (113.4)	36.4
HG-KR43(B) HG-MR43(B)	98.3 (135.1)	58.1

Dimensions for motors with brake in brackets ().

Unit: mm

HG-KR73(B), HG-MR73(B)

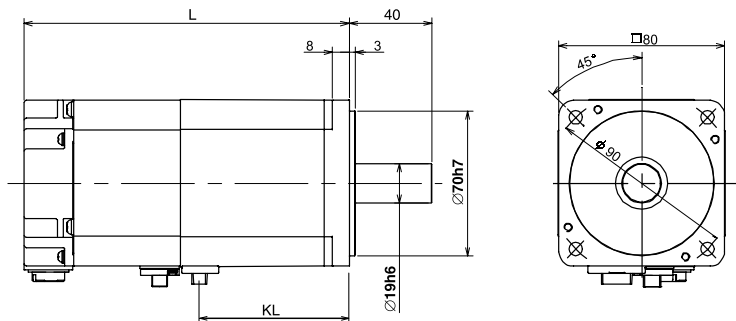

Type	L [mm]	KL [mm]
HG-KR73(B) HG-MR73(B)	112 (152.3)	69.6

Dimensions for motors with brake in brackets ().

Unit: mm

HG-SR52(B), HG-SR524(B), HG-SR102(B), HG-SR1024(B), HG-SR152(B), HG-SR1524(B)

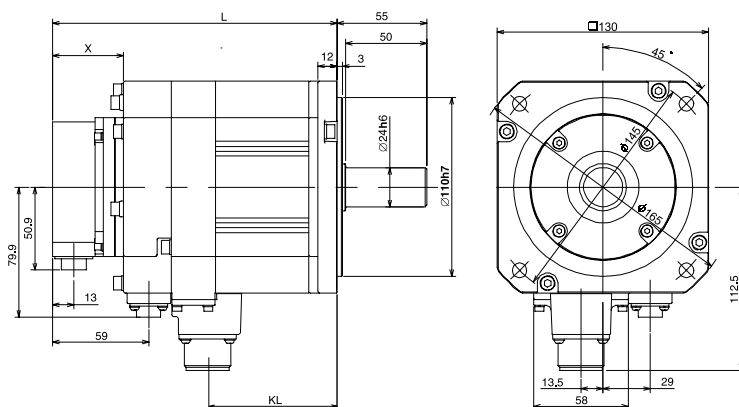

Type	L [mm]	KL [mm]	X [mm]
HG-SR52(B) HG-SR524(B)	118.5 (153.0)	57.8	38.2 (43.5)
HG-SR102(B) HG-SR1024(B)	132.5 (167)	71.8	38.2 (43.5)
HG-SR152(B) HG-SR1524(B)	146.5 (181)	85.8	38.2 (43.5)

Dimensions for motors with brake in brackets ().

Unit: mm

HG-SR202(B), HG-SR352(B), HG-SR502(B), HG-SR702(B), HG-SR2024(B), HG-SR3524(B), HG-SR5024(B), HG-SR7024(B),

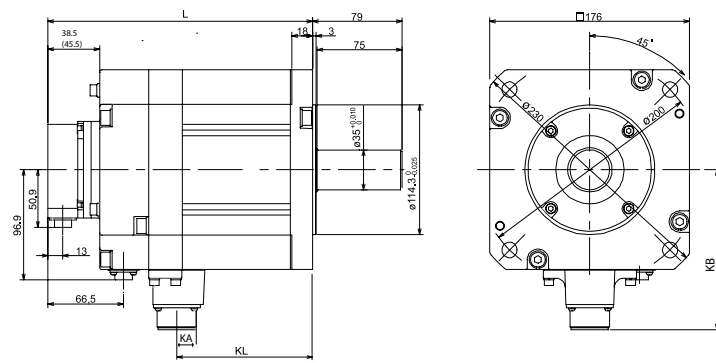

Type	L [mm]	KL [mm]	KA [mm]	KB [mm]
HG-SR202(B) HG-SR2024(B)	138.5 (188)	74.8		
HG-SR352(B) HG-SR3524(B)	162.5 (212)	98.8	24.8	140.9
HG-SR502(B) HG-SR5024(B)	178.5 (228)	114.8		
HG-SR702(B) HG-SR7024(B)	218.5 (268)	146.8	32	149.1

Dimensions for motors with brake in brackets ().

Unit: mm

**HG-JR53(B), HG-JR534(B), HG-JR73(B), HG-JR734(B), HG-JR103(B), HG-JR1034(B),
HG-JR153(B), HG-JR1534(B), HG-JR203(B), HG-JR2034(B)**

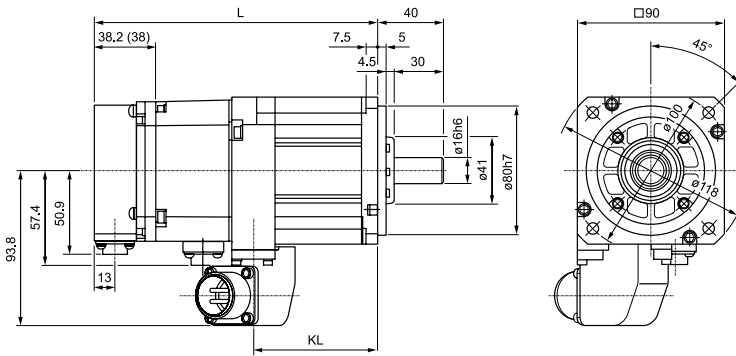

Type	L [mm]	KL [mm]
HG-JR53(B) HG-JR534(B)	127.5 (173)	76
HG-JR73(B) HG-JR734(B)	145.5 (191)	94
HG-JR103(B) HG-JR1034(B)	163.5 (209)	112
HG-JR153(B) HG-JR1534(B)	199.5 (245)	148
HG-JR203(B) HG-JR2034(B)	235.5 (281)	184

Dimensions for motors with brake in brackets ().

Unit: mm

HG-JR353(B), HG-JR503(B)

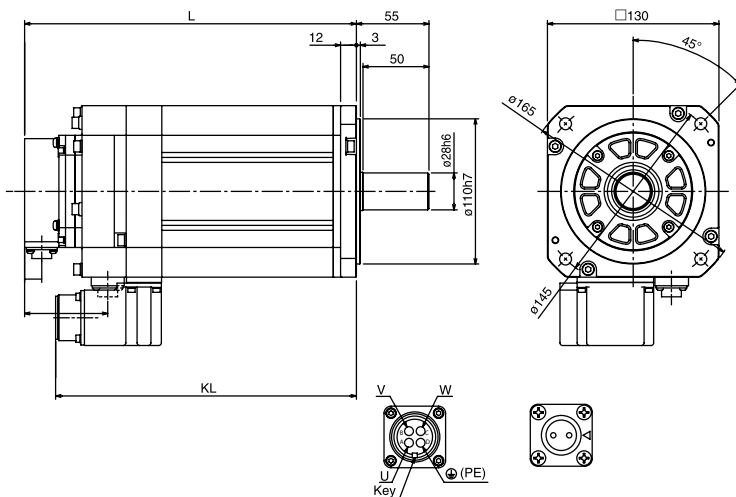

Type	L [mm]	KL [mm]
HG-JR353(B)	213 (251.5)	228
HG-JR5034(B)	267 (305.5)	282

Dimensions for motors with brake in brackets ().

Unit: mm

HG-JR3534(B), HG-JR5034(B)

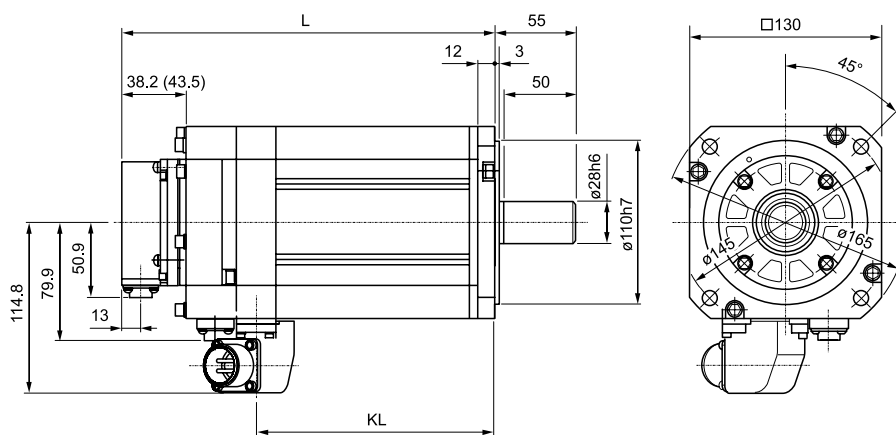

Type	L [mm]	KL [mm]
HG-JR3534(B)	213 (251.5)	161
HG-JR5034(B)	267 (305.5)	215

Dimensions for motors with brake in brackets ().

Unit: mm

HG-JR703(B), HG-JR903(B), HG-JR7034(B), HG-JR9034(B)

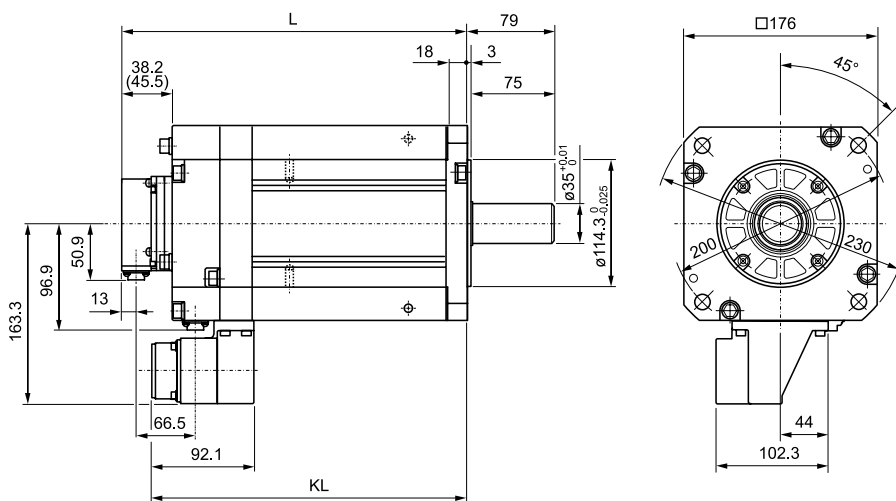

Type	L [mm]	KL [mm]
HG-JR703(B)	263.5 (313)	285.4
HG-JR7034(B)	263.5 (313)	285.4
HG-JR903(B)	303.5 (353)	325.4
HG-JR9034(B)	303.5 (353)	325.4

Dimensions for motors with brake in brackets ().

Unit: mm

HG-JR11K1M(B), HG-JR15K1M(B), HG-JR11K1M4(B), HG-JR15K1M4(B)

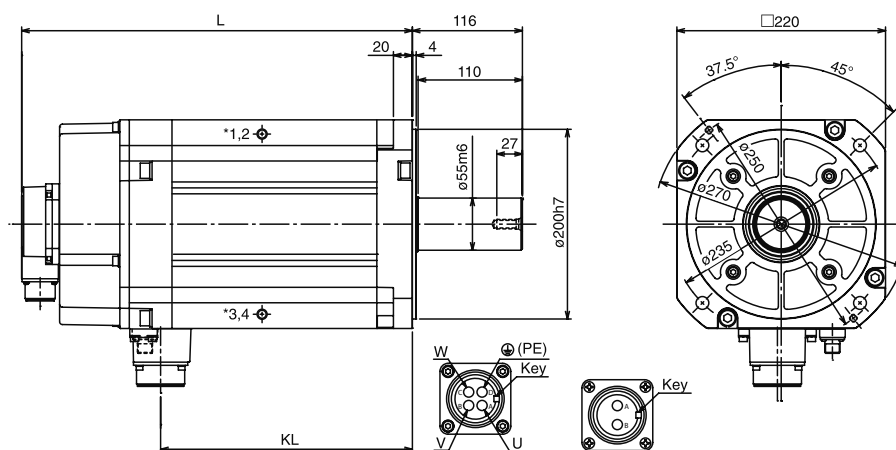

Type	L [mm]	KL [mm]
HG-JR11K1M(B)	339.5 (412)	265.5
HG-JR11K1M4(B)	339.5 (412)	265.5
HG-JR15K1M(B)	439.5 (512)	365.5
HG-JR15K1M4(B)	439.5 (512)	365.5

Dimensions for motors with brake in brackets ().

Unit: mm

HG-JR22K1M, HG-JR22K1M4

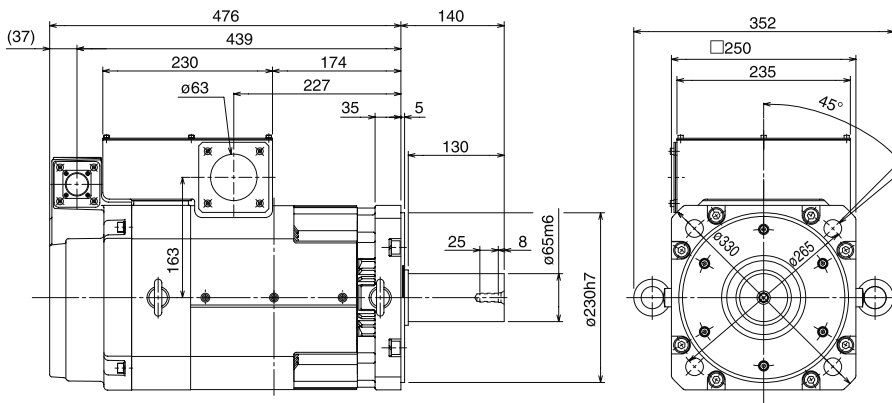

HG-RR103(B), HG-RR153(B), HG-RR203(B)

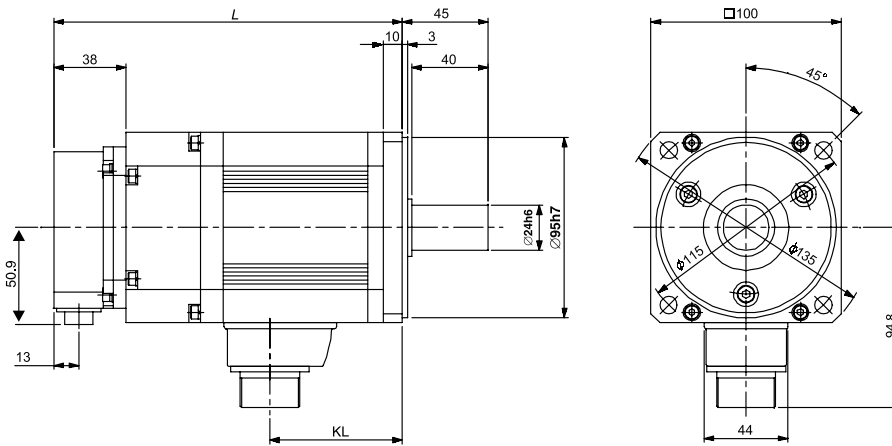

Type	L [mm]	KL [mm]
HG-RR103(B)	145.5 (183)	69.5
HG-RR153(B)	170.5 (208)	94.5
HG-RR203(B)	195.5 (233)	119.5

Dimensions for motors with brake in brackets ().

Unit: mm

HG-RR353(B), HG-RR503(B)

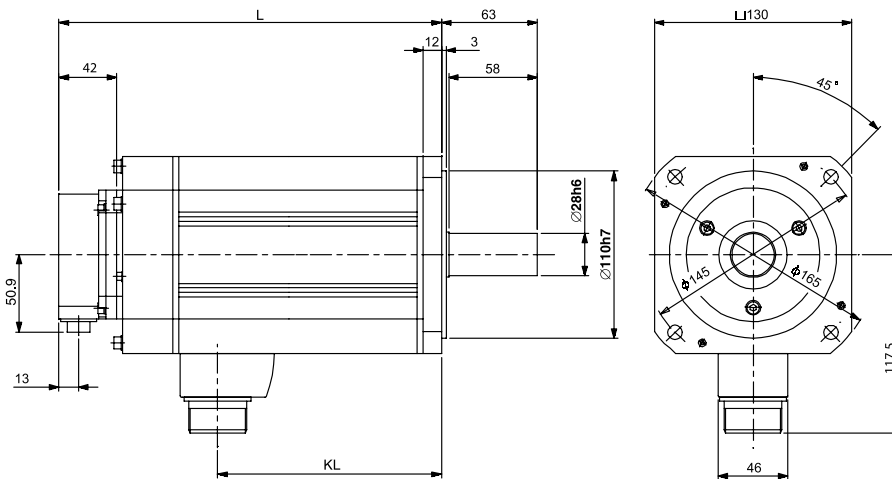

Type	L [mm]	KL [mm]
HG-RR353(B)	215.5 (252)	147.5
HG-RR503(B)	272.5 (309)	204.5

Dimensions for motors with brake in brackets ().

Unit: mm

HF-KN13(B)

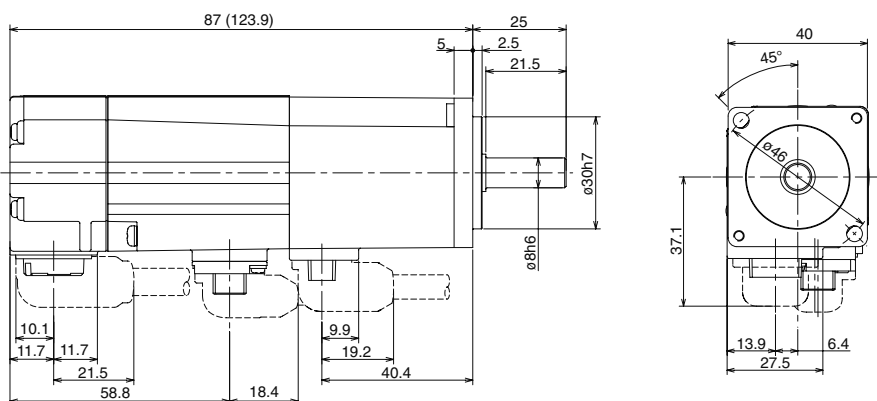

HF-KN23(B), HF-KN43(B)

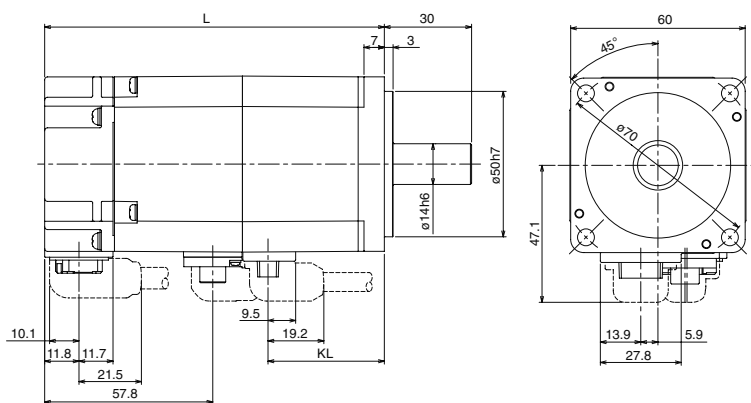

Type	L [mm]	KL [mm]
HF-KN23(B)	88.2 (116.8)	40
HF-KN43(B)	110.2 (138.8)	62

Dimensions for motors with brake in brackets ().

Unit: mm

HF-KN73(B)J

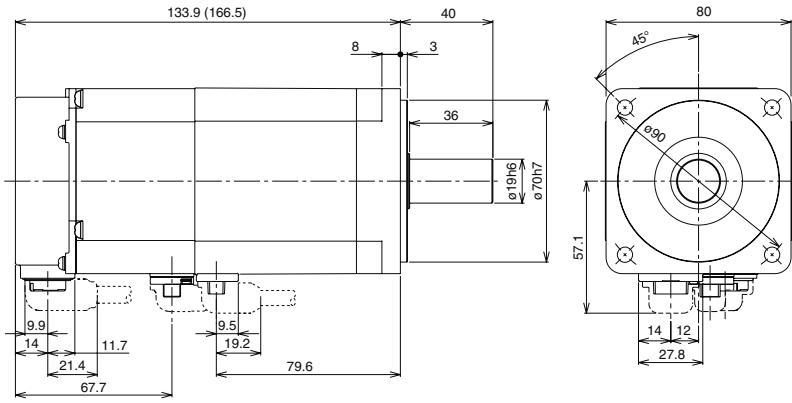

HF-SN52(B)J, HF-SN102(B)J, HF-SN152(B)J

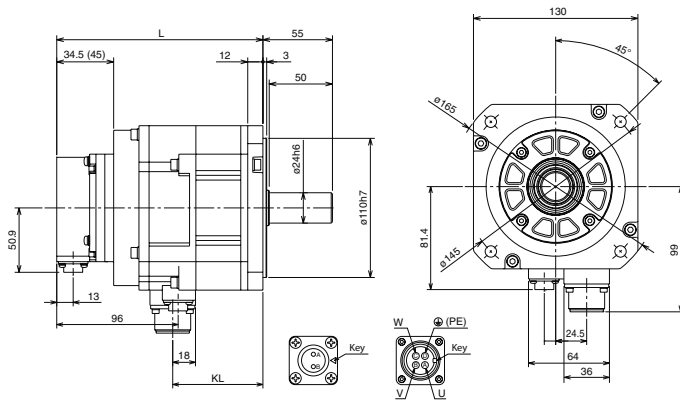

Type	L [mm]	KL [mm]
HF-SN52(B)J	125 (163)	71.3
HF-SN102(B)J	141 (179)	87.3
HF-SN152(B)J	163 (201)	109.3

Dimensions for motors with brake in brackets ().

Unit: mm

HF-SN202(B)J, HF-SN302(B)J

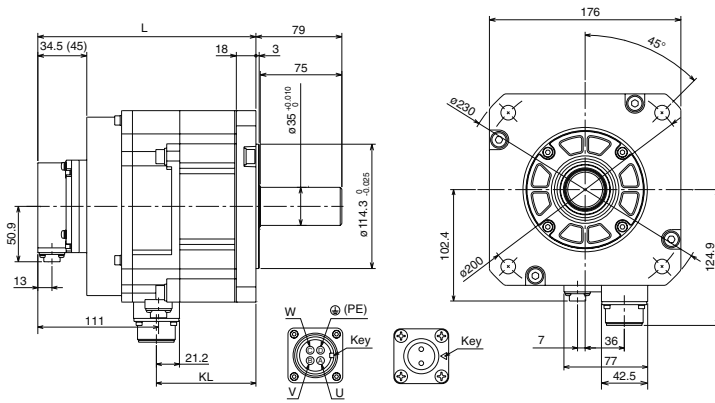

Type	L [mm]	KL [mm]
HF-SN202(B)J	148.5 (200.5)	91.5
HF-SN302(B)J	178.5 (230.5)	121.5

Dimensions for motors with brake in brackets ().

Unit: mm

Servo Amplifiers MR-J4-A(4)/B(4)/MR-J4W2/3-B

MR-J4-10A, MR-J4-20A

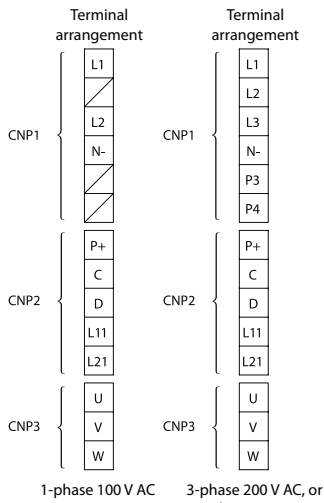
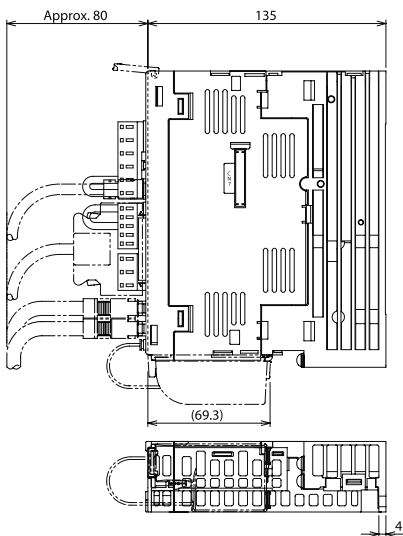
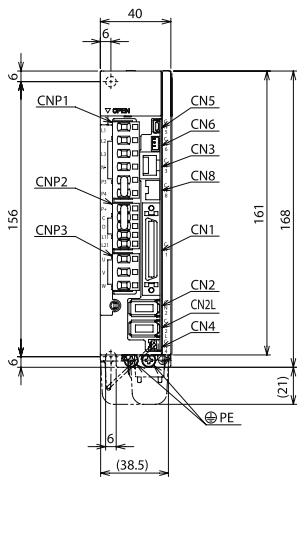

Unit: mm

MR-J4-40A, MR-J4-60A

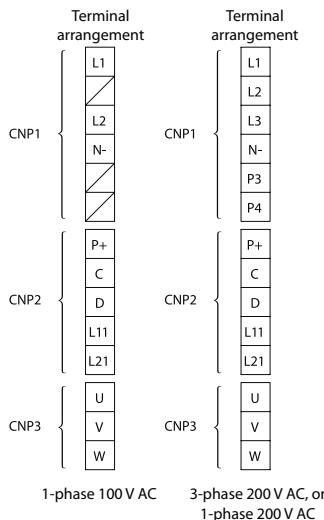
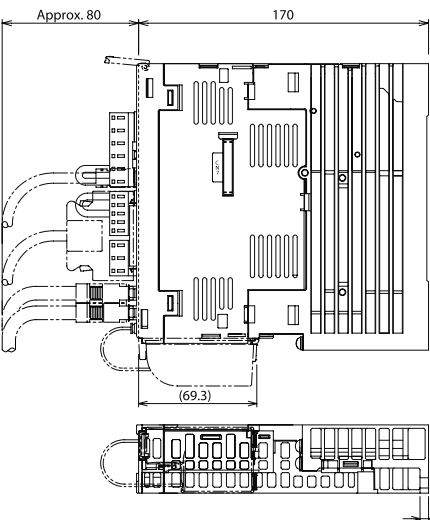
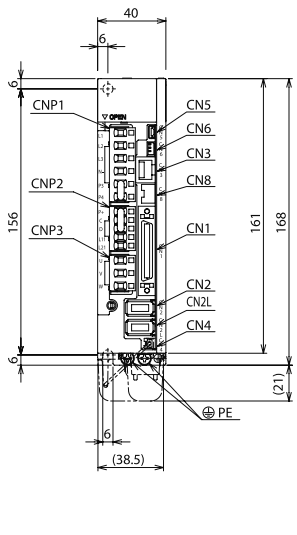

Unit: mm

MR-J4-70A, MR-J4-100A

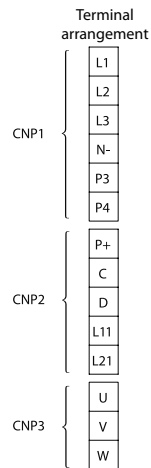
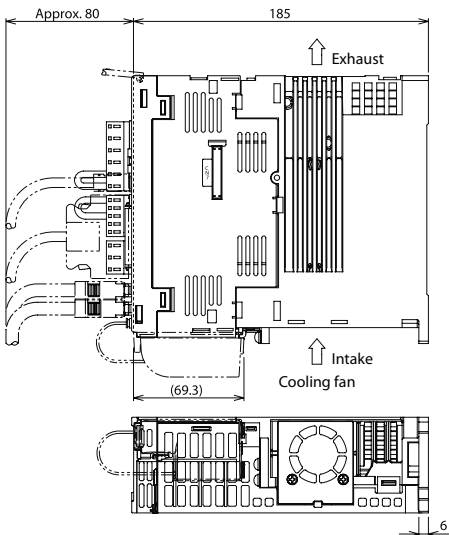
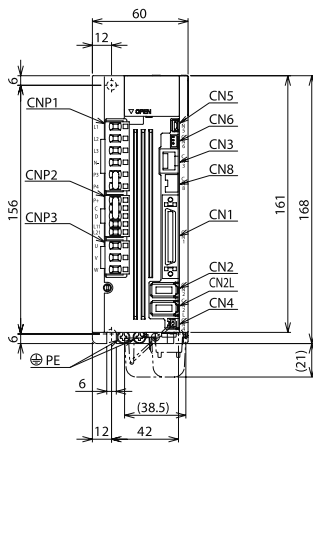

Unit: mm

Dimensions Servo Amplifiers

MR-J4-60A4, MR-J4-100A4

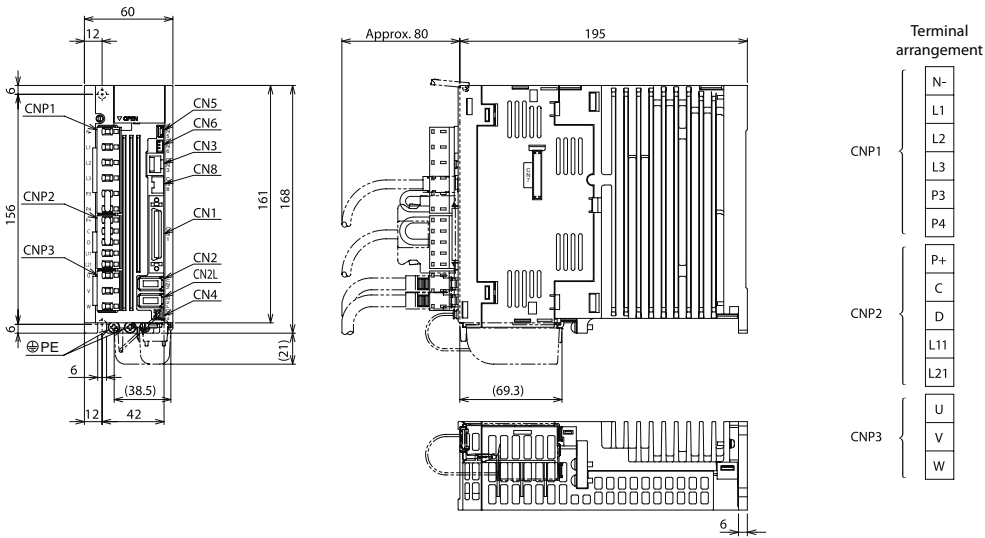

Unit: mm

MR-J4-200A

6

Dimensions

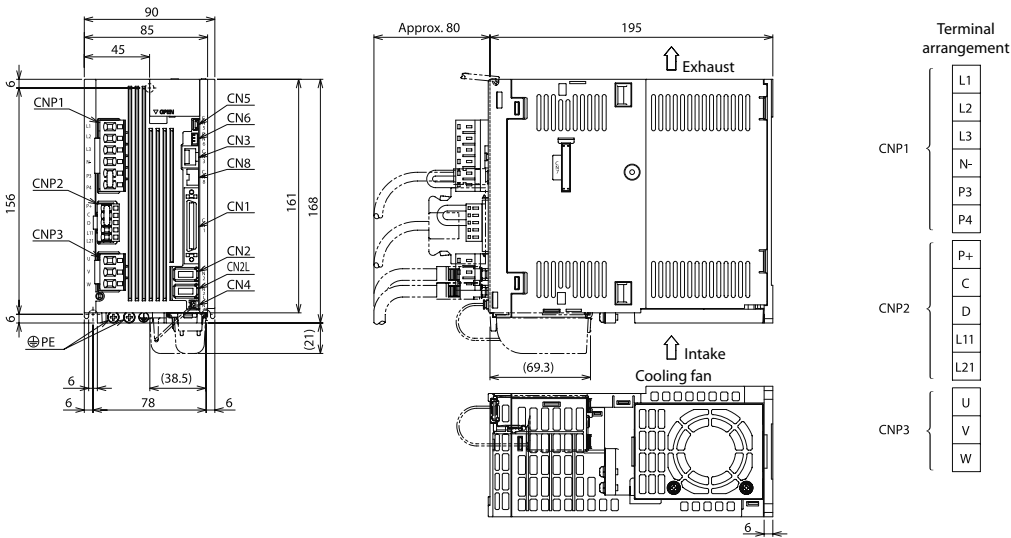

Unit: mm

MR-J4-200A4

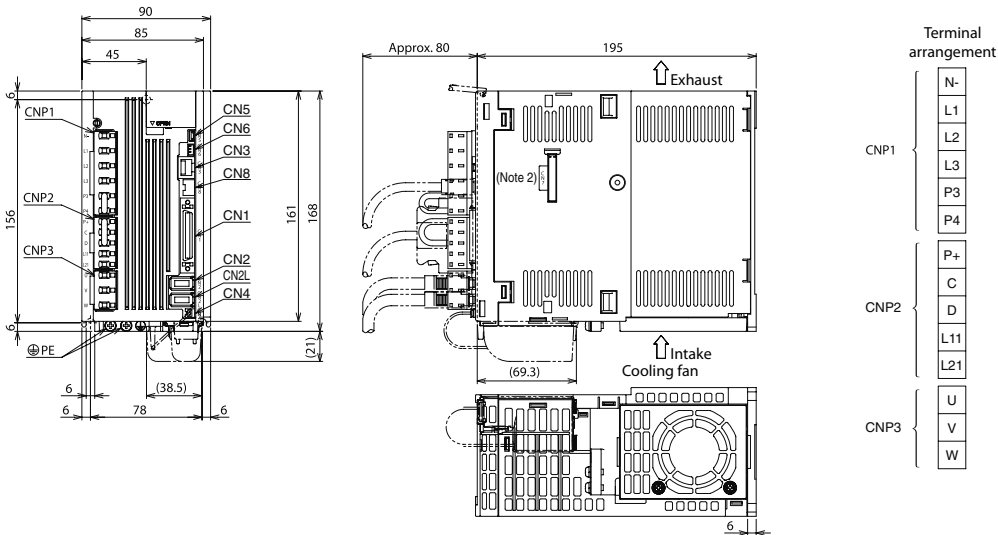

Unit: mm

MR-J4-350A

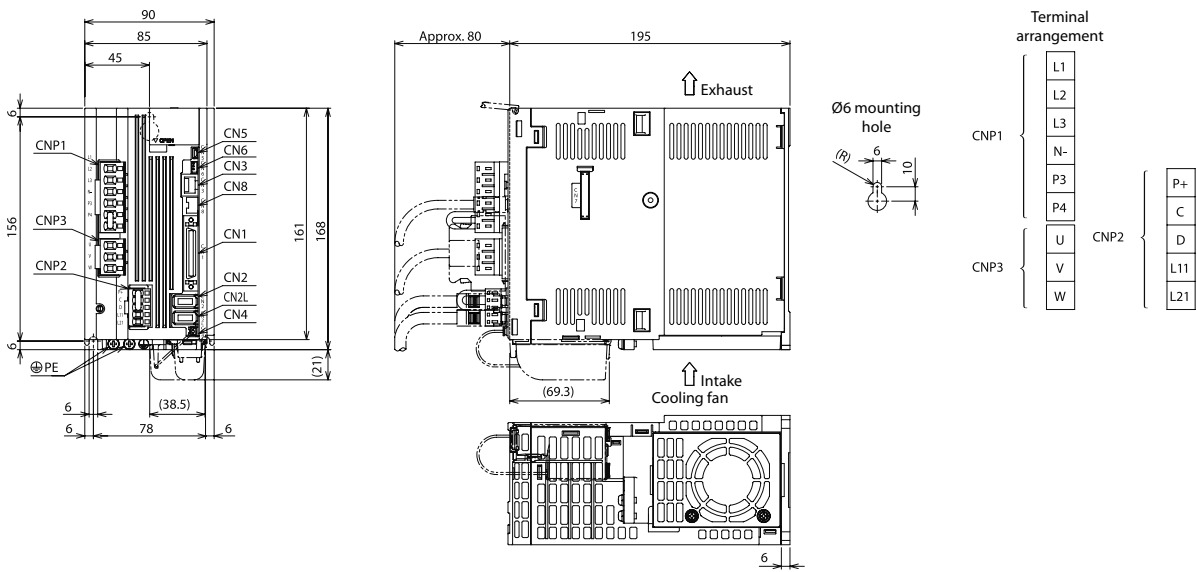

Unit: mm

MR-J4-350A4

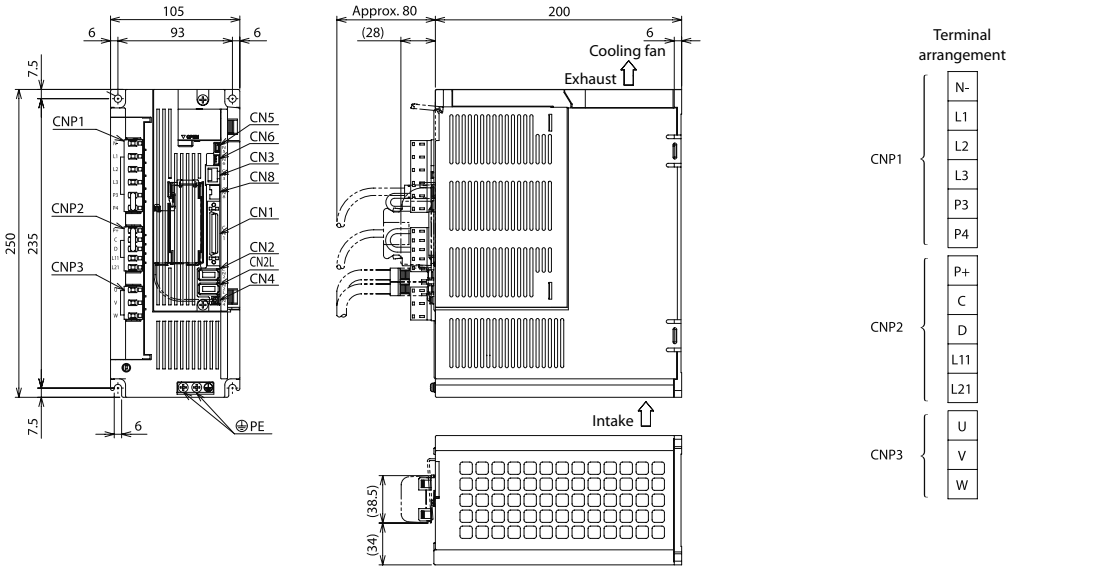

Unit: mm

MR-J4-500A

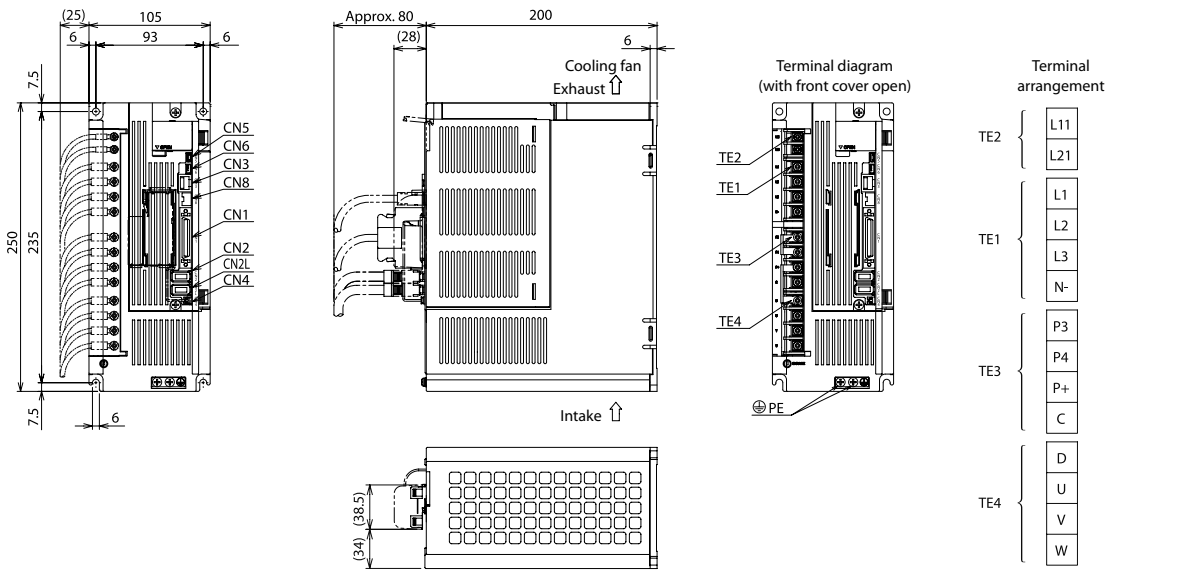

Unit: mm

MR-J4-500A4

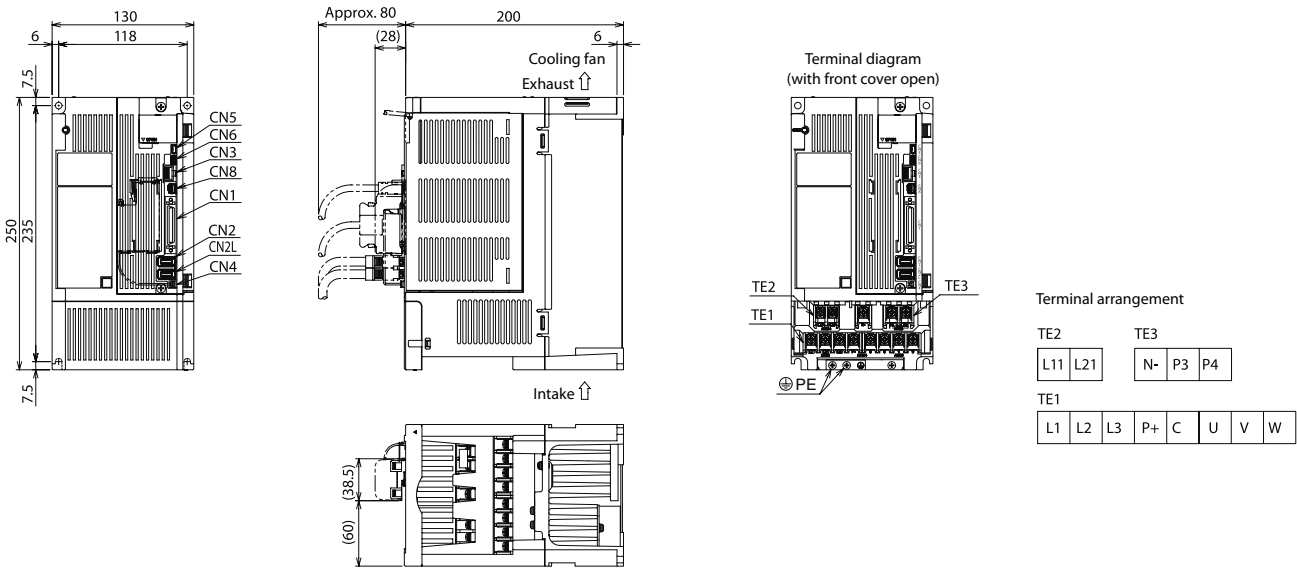

Unit: mm

MR-J4-700A, MR-J4-700A4

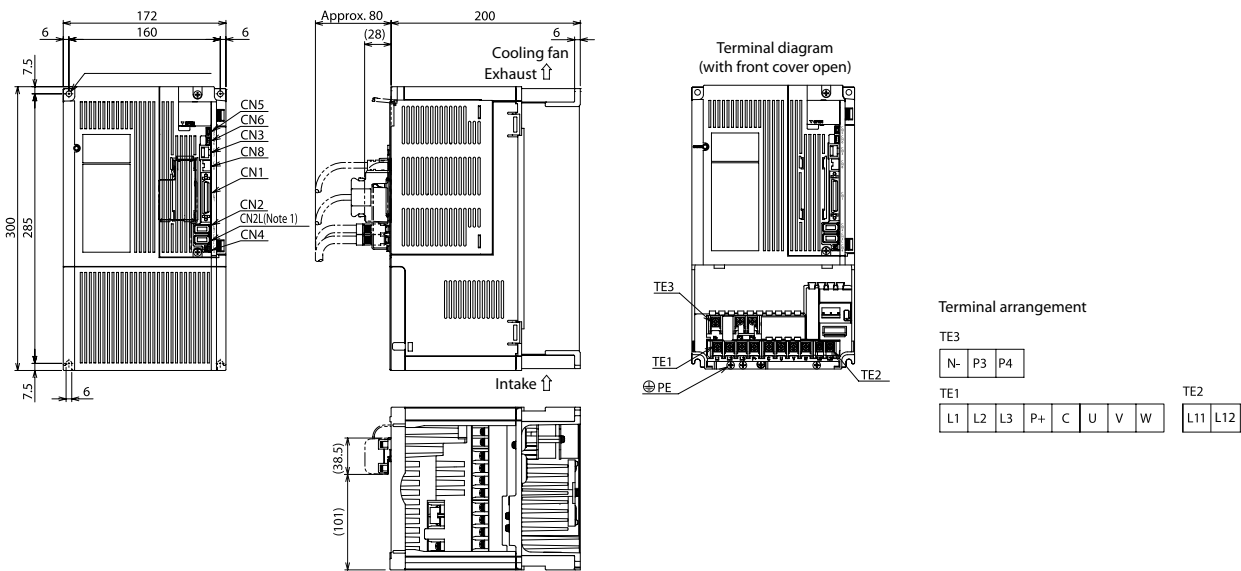

Unit: mm

MR-J4-11KA, MR-J4-11KA4, MR-J4-15KA, MR-J4-15KA4

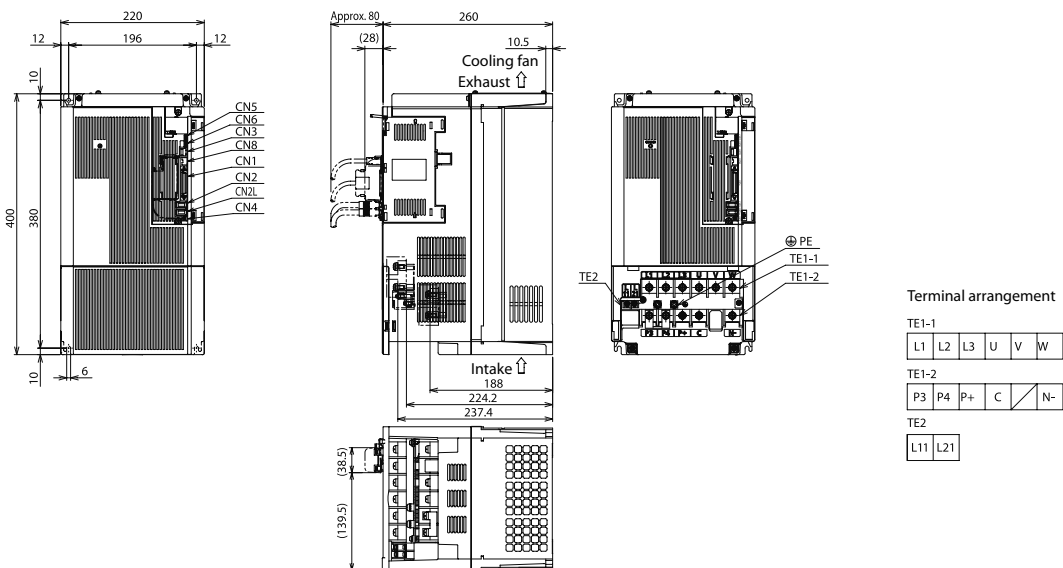

Unit: mm

MR-J4-22KA, MR-J4-22KA4

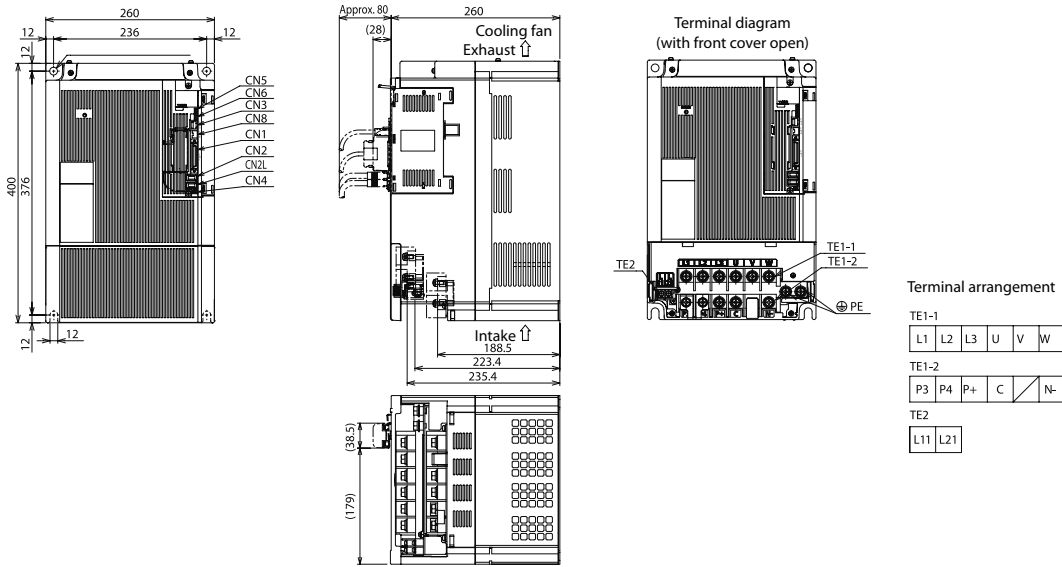

Unit: mm

MR-J4-10B, MR-J4-20B

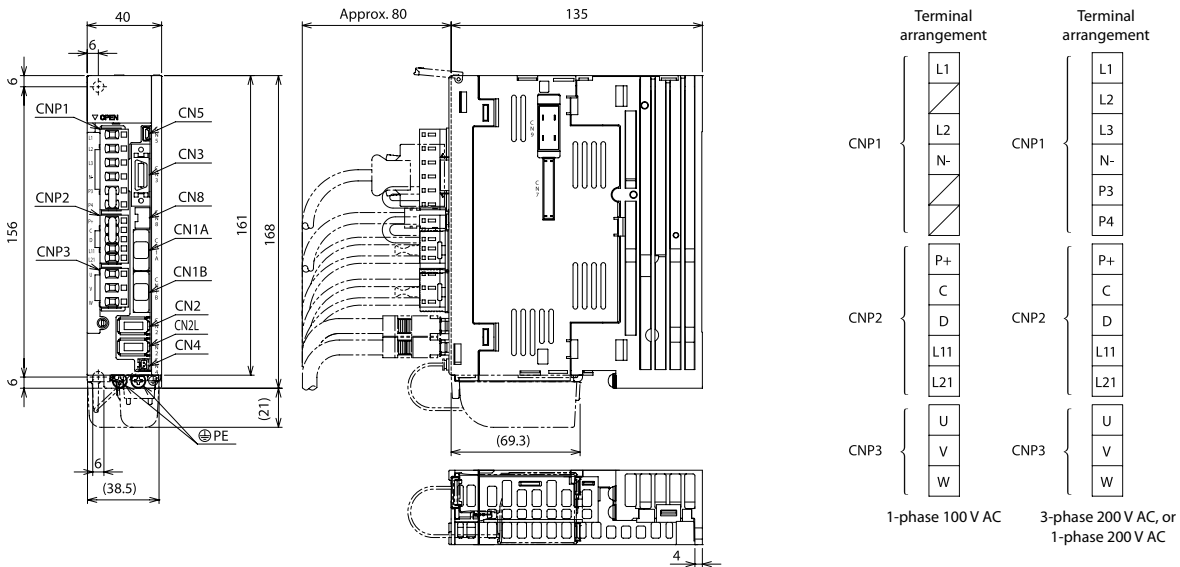

Unit: mm

MR-J4-40B, MR-J4-60B

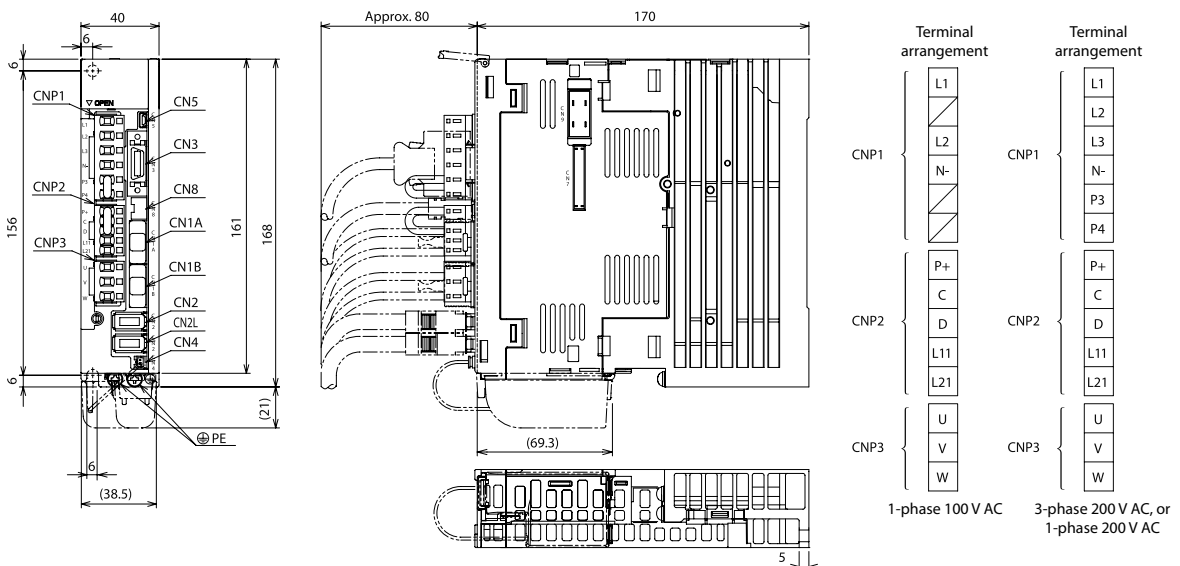

Unit: mm

Dimensions Servo Amplifiers

MR-J4-70B, MR-J4-100B

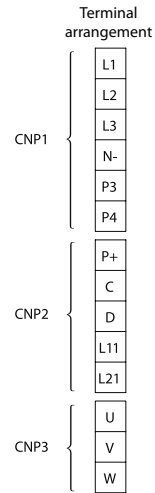
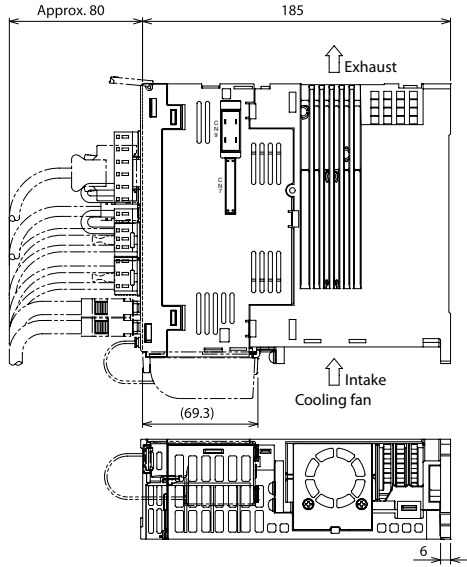
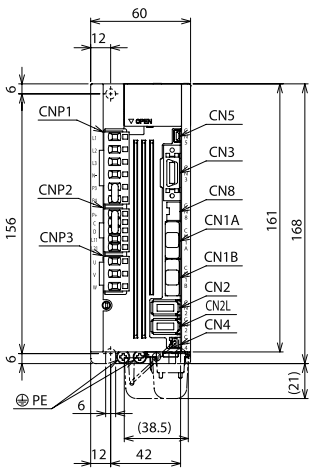

Unit: mm

MR-J4-60B4, MR-J4-100B4

6

Dimensions

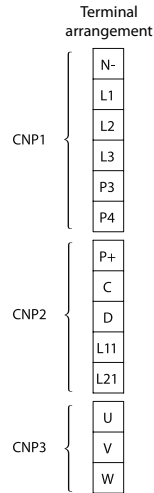
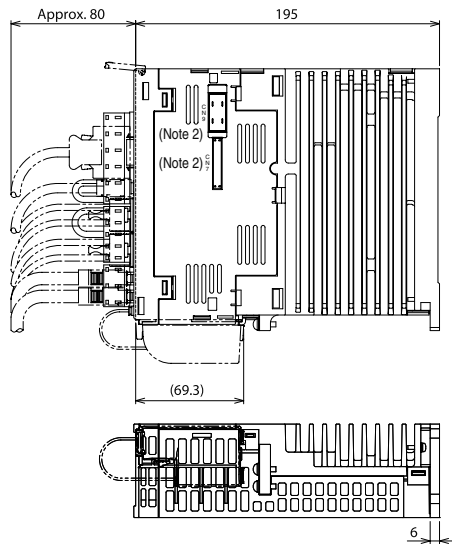
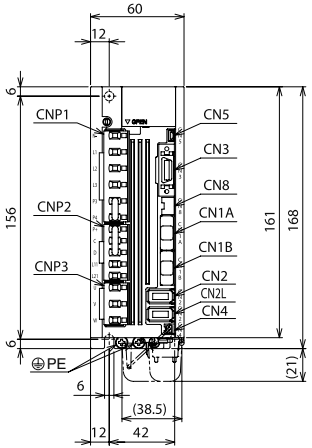

Unit: mm

MR-J4-200B

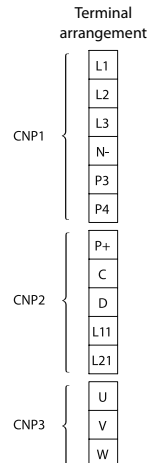
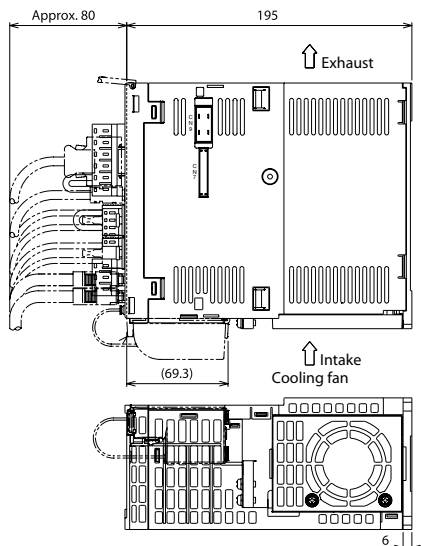
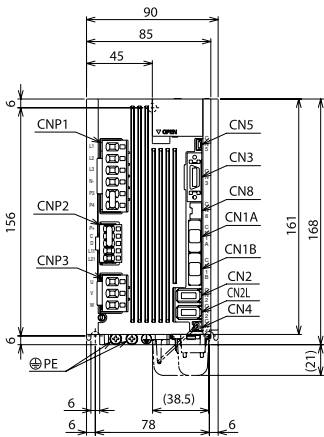

Unit: mm

MR-J4-200B4

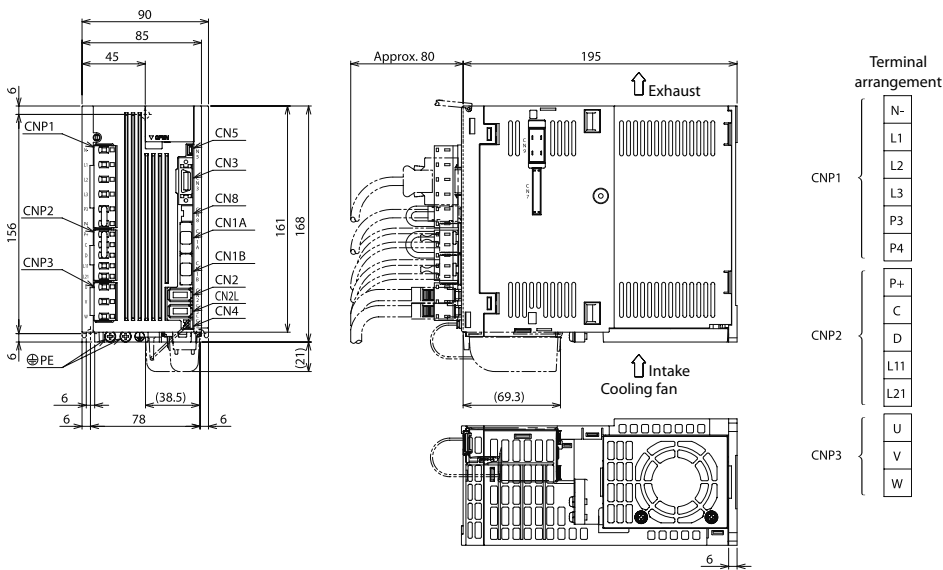

Unit: mm

MR-J4-350B

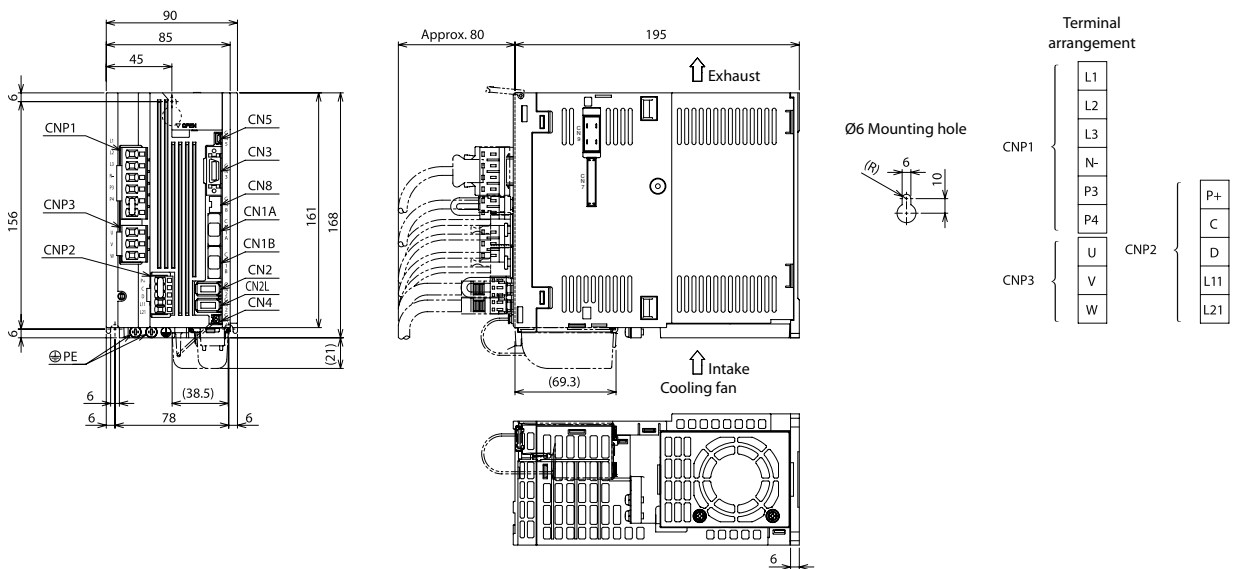

Unit: mm

MR-J4-350B4

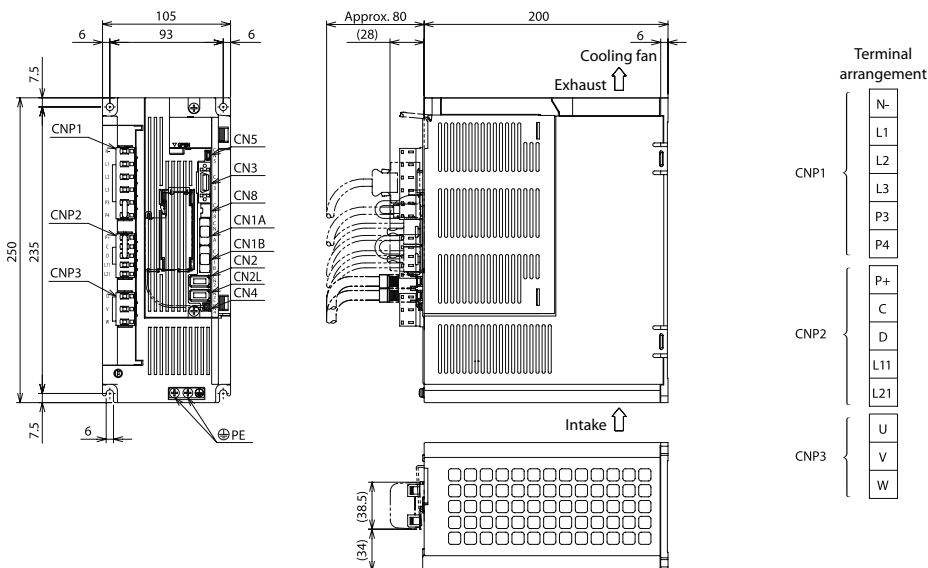

Unit: mm

MR-J4-500B

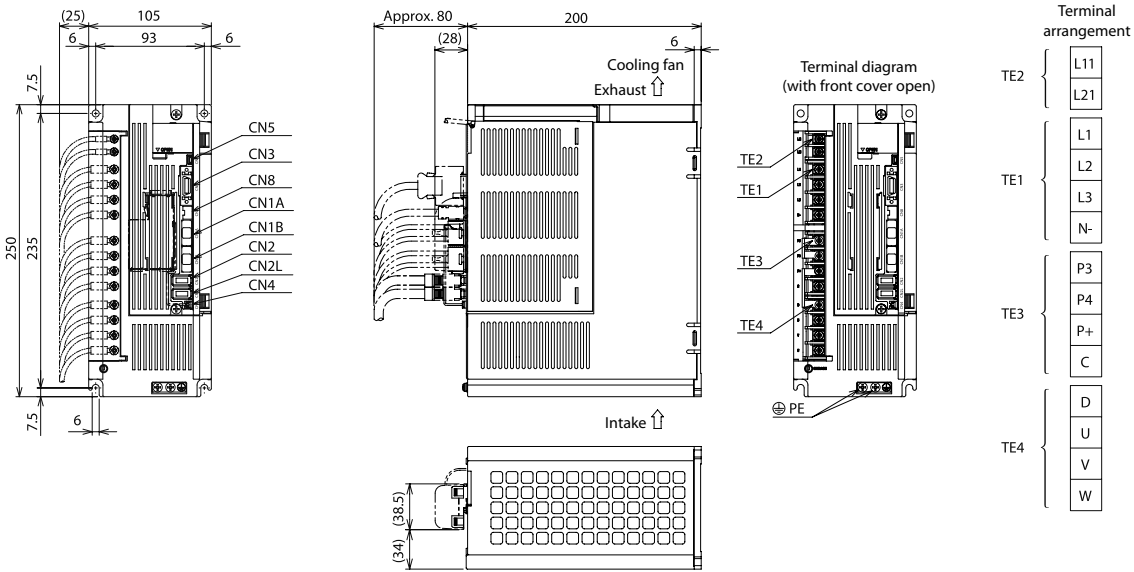

Unit: mm

MR-J4-500B4

6

Dimensions

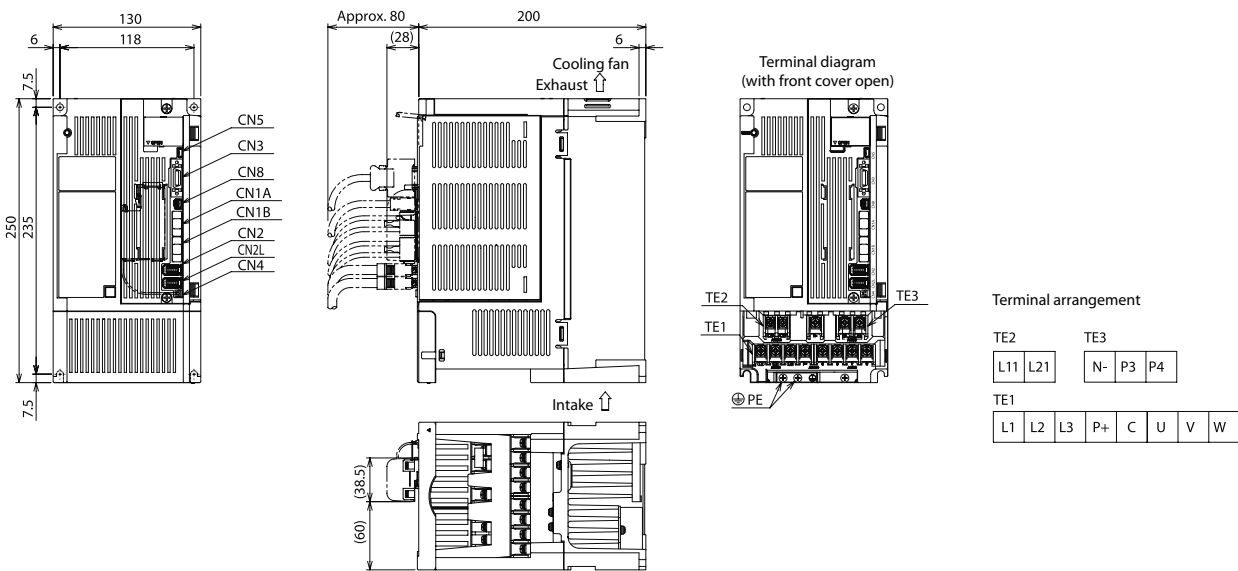

Unit: mm

MR-J4-700B, MR-J4-700B4

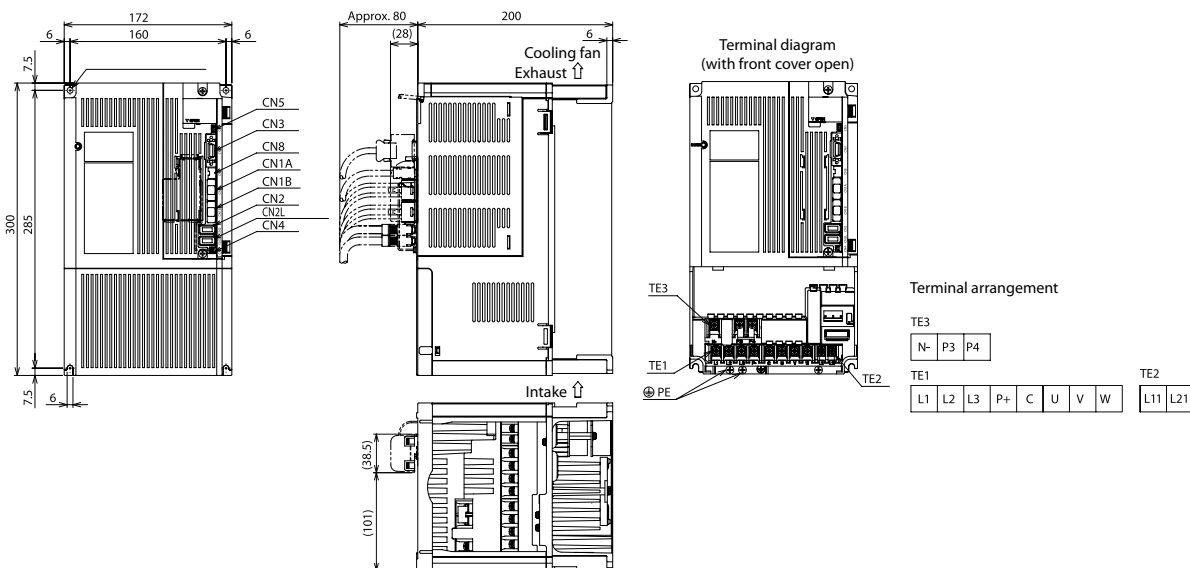

Unit: mm

MR-J4-11KB, MR-J4-11KB4, MR-J4-15KB, MR-J4-15KB4

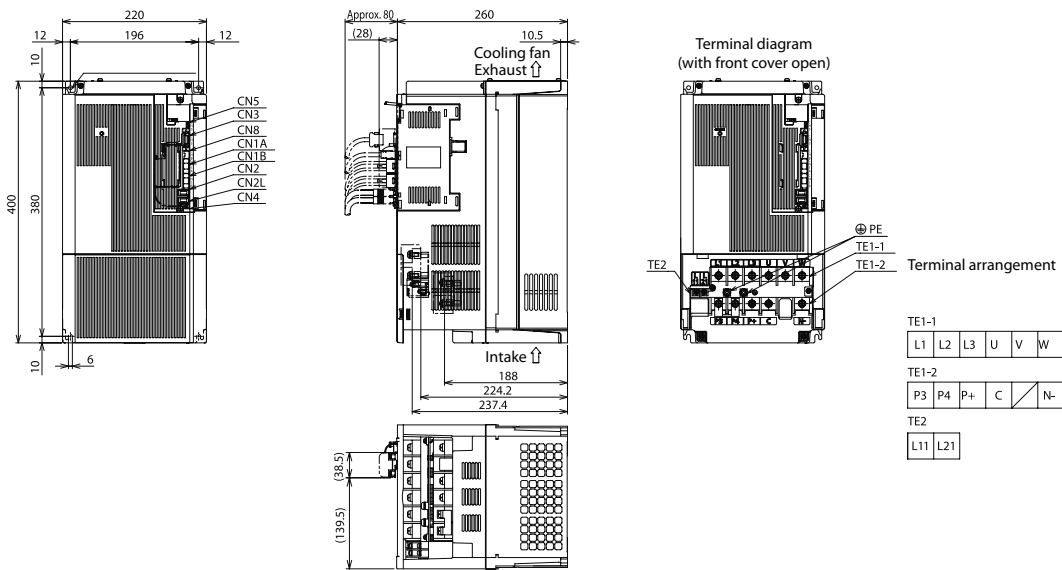

Unit: mm

MR-J4-22KB, MR-J4-22KB4

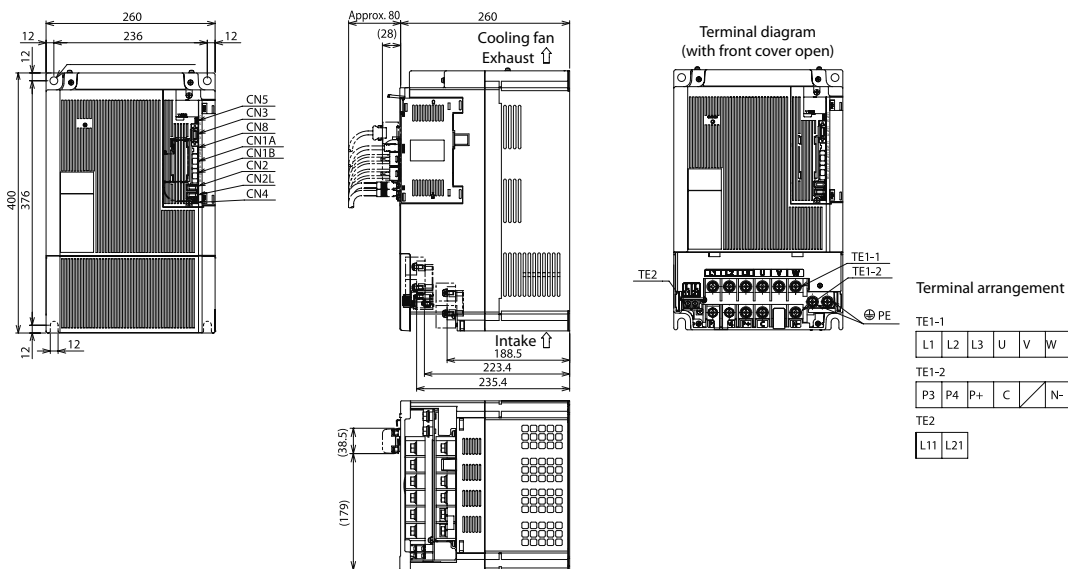

Unit: mm

MR-J4W2-22B, MR-J4W2-44B

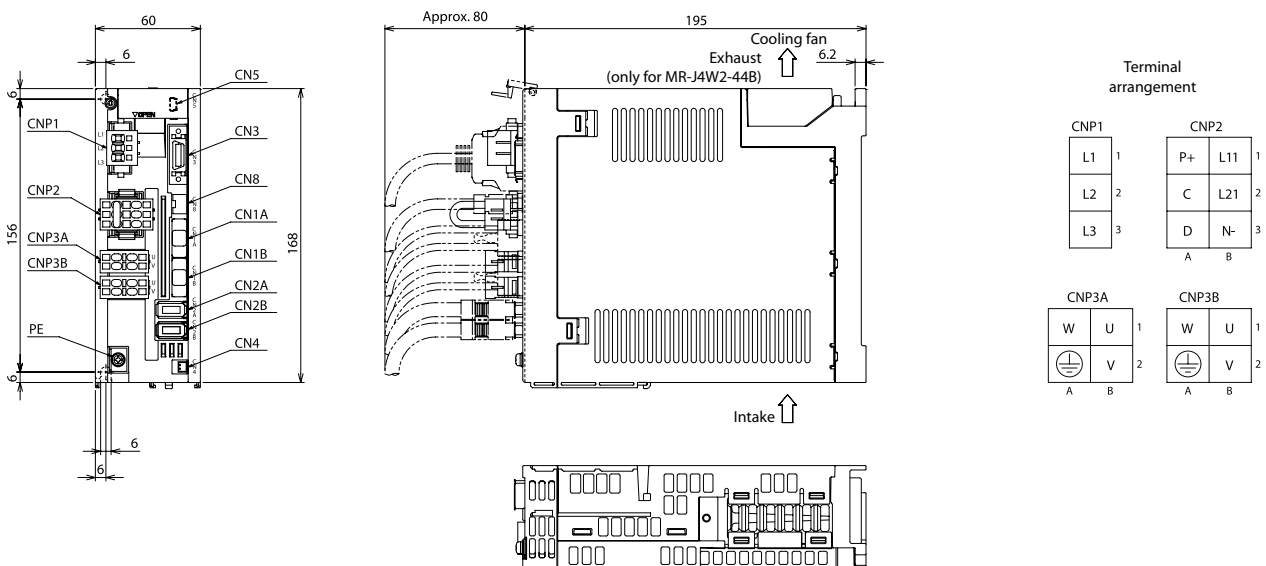

Unit: mm

Dimensions Servo Amplifiers

MR-J4W2-77B, MR-J4W2-1010B

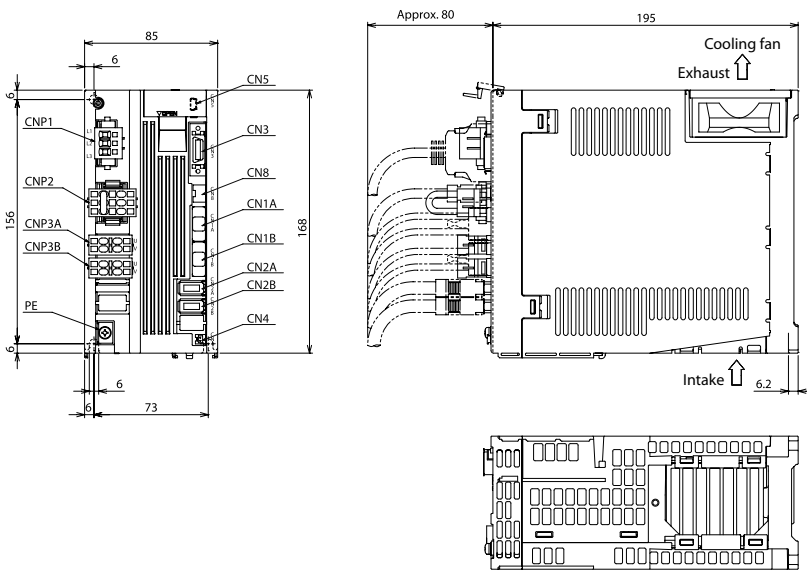

Unit: mm

MR-J4W3-222B, MR-J4W3-444B

6

Dimensions

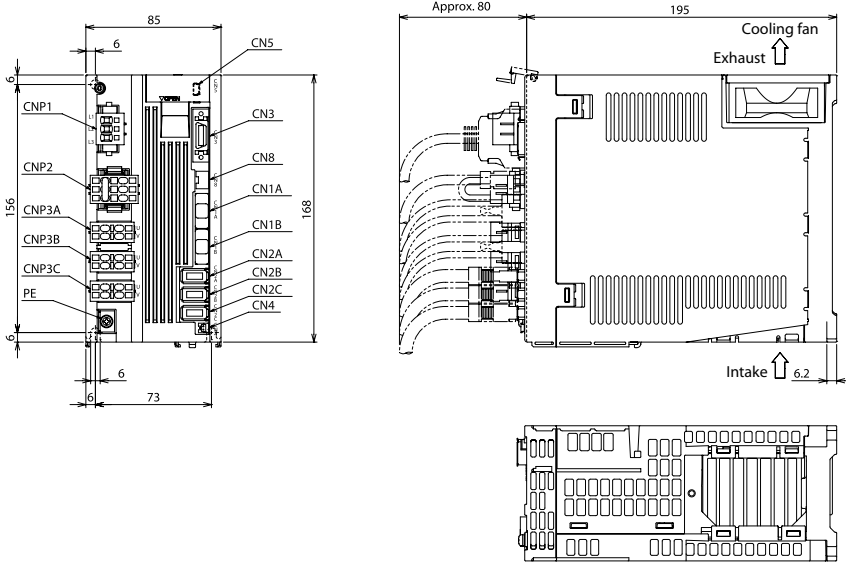

Unit: mm

Servo Amplifiers MR-JE

MR-JE-10A, MR-JE-20A, MR-JE-40A

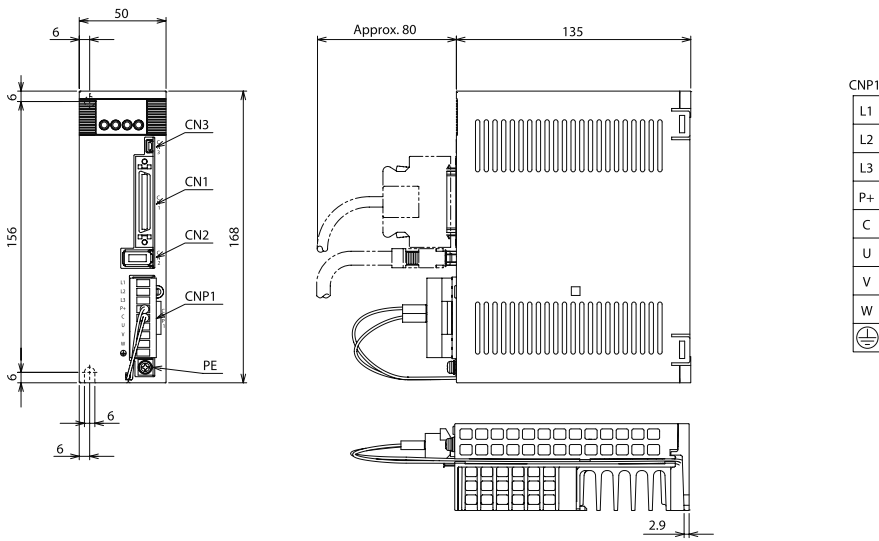

Unit: mm

MR-JE-70A, MR-JE-100A

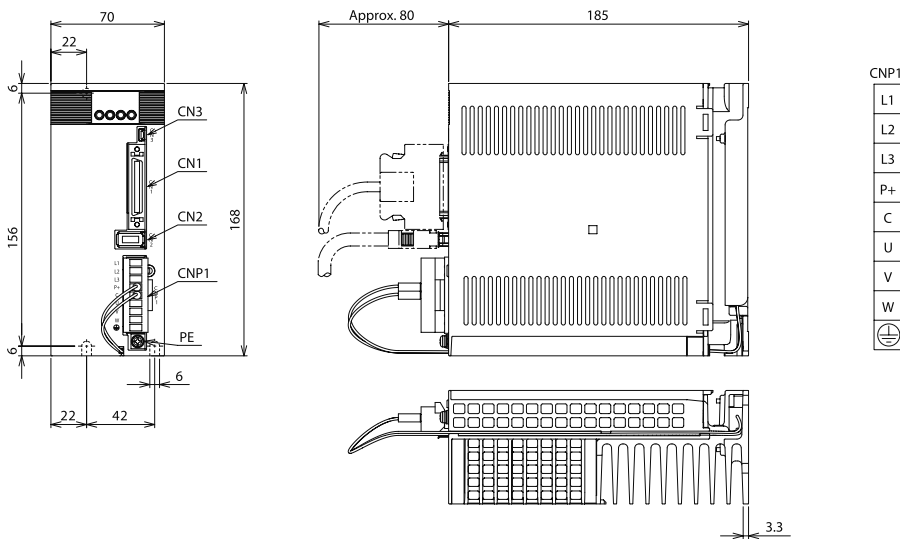

Unit: mm

MR-JE-200A, MR-JE-300A

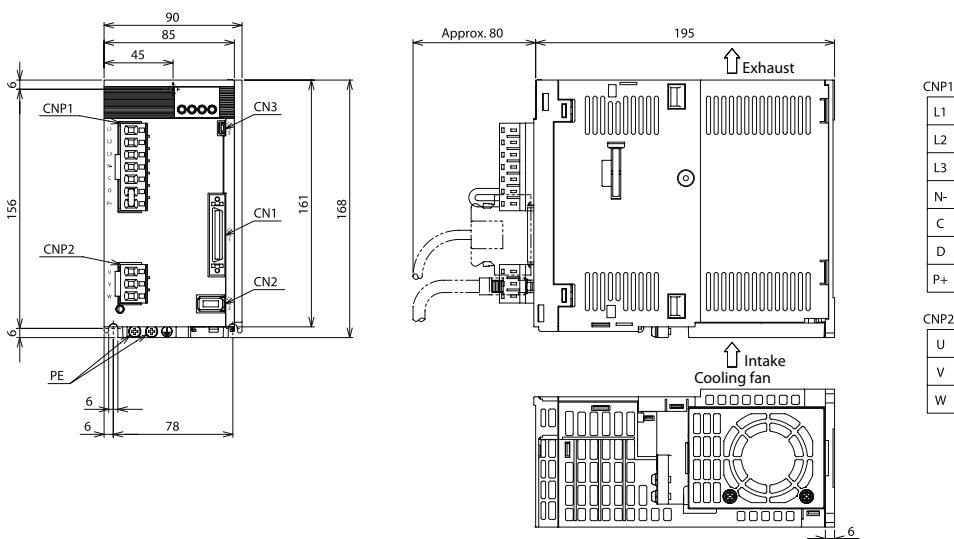

Unit: mm

■ EMC Filters

MF-2F230-006.230MFa to MF-3F480-015.230MF3 and MF-3F480-035.230

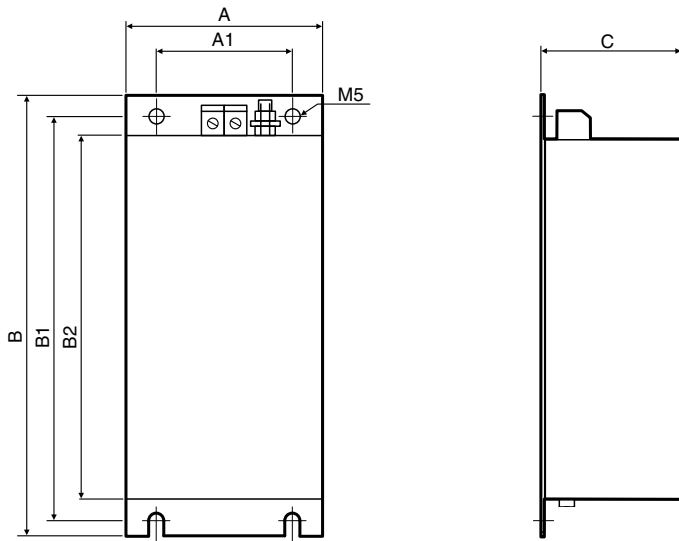

Type	A	A1	B	B1	B2	C
MF-2F230-006.230MFa	40	28	200	190	170	40
MF-2F230-006.230MFb	60	42	200	190	170	40
MF-3F480-015.233MF	130	118	282	270	—	66
MF-3F480-010.233MF	60	42	202	192	172	55
MF-3F480-015.230MF3	90	78	204	192	172	55
MF-3F480-015.234MF	105	93	282	270	235	55
MF-3F480-035.230	75	60	168	156	140	195

Unit: mm

6

Dimensions

MF-3F230-011.230, MF-3F480-025.230MF3, MF-3F480-050.230MF3

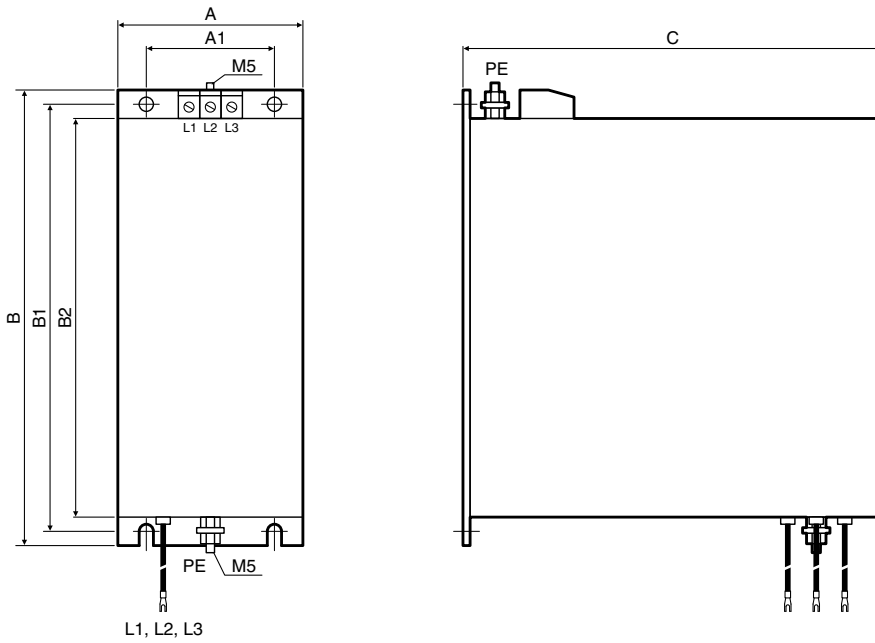

Type	A	A1	B	B1	B2	C
MF-3F230-011.230	45	36	168	156	140	135
MF-3F480-025.230MF3	76	60	168	156	140	195
MF-3F480-050.230MF3	75	45	250	235	220	200

Unit: mm

FMR-ES-3A-RS1-FP, FMR-ES-6A-RS1-FP

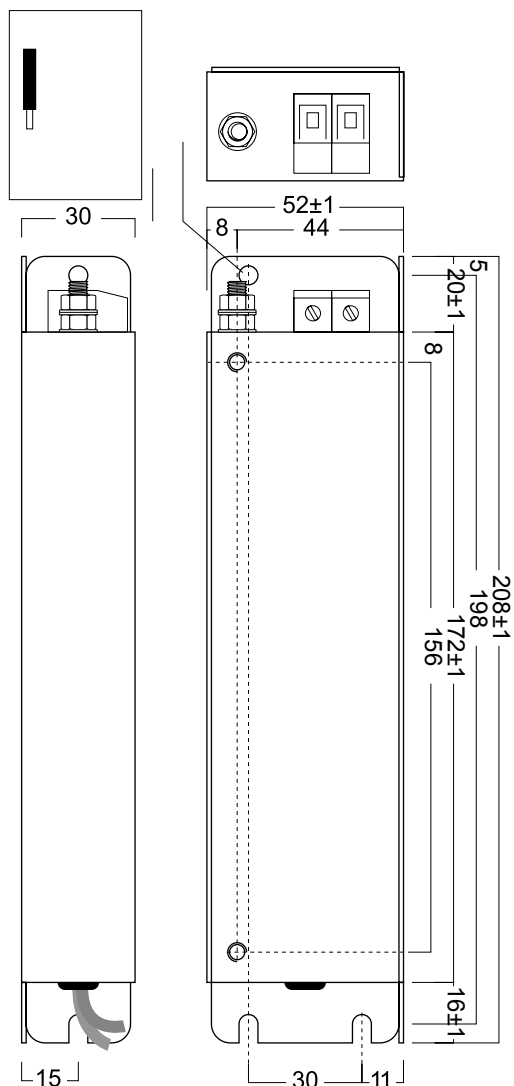

Type	A	A1	A2	A3	A4	B	B1	B2	B3	C	C1
FMR-ES-3A-RS1-FP	52±1	8	44	30	11	156	172±1	198	208±1	30	15
FMR-ES-6A-RS1-FP	72±1	—	42	50	11	156	172±1	198	208±1	30	15

Unit: mm

■ Brake Resistors

MR-RFH, MR-PWR-R

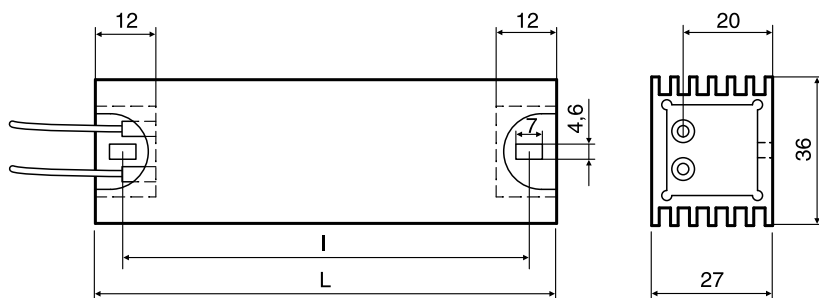

Type	L	I
MR-RFH75-40	90	79
MR-RFH220-40	200	189
MR-RFH400-13	320	309
MR-RFH400-6.7	320	309
MR-PWR-RT 400-120	200	189
MR-PWR-RT 600-26	320	309
MR-PWR-RT 600-9	320	309
MR-PWR-RT 600-47	320	309

Unit: mm

■ Functional safety unit MR-D30

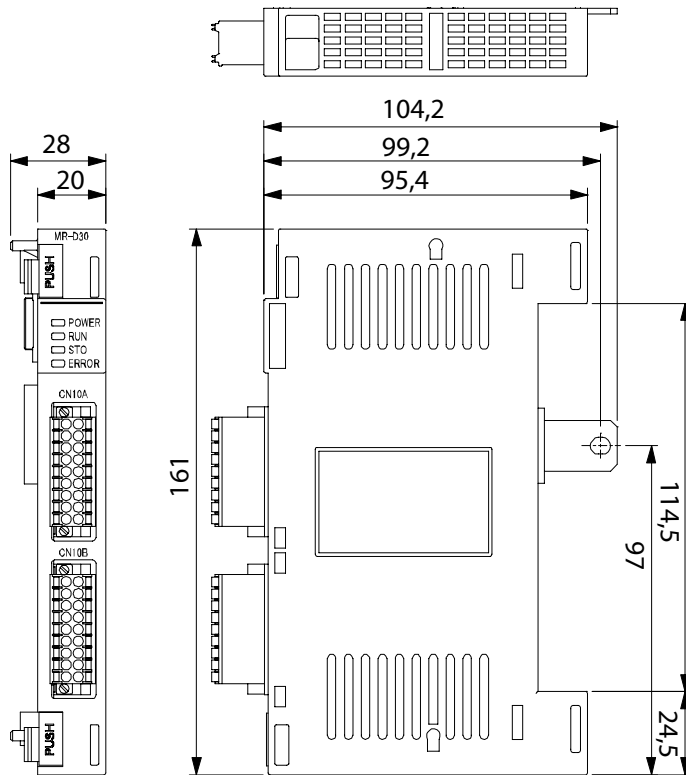

Unit: mm

■ Extension I/O Unit MR-J3-D01

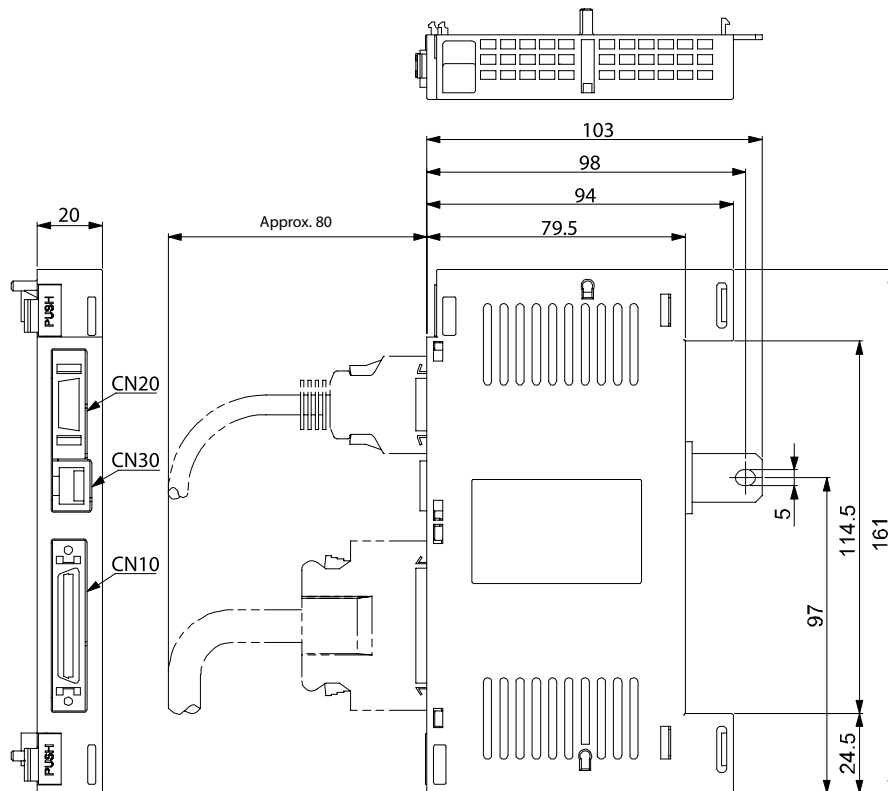

Unit: mm

Symbols

2-axis/3-axis Types for Energy-conservative	9
A	
Advanced Servo Gain Adjustment Function	8
B	
Brake Resistors	52
Buffer Battery	51
C	
Cables and Connectors	37
Detailed	44
Overview for Servo Amplifiers	37
Overview for Servo Motors	40
Connections with Peripheral Equipment	34
MR-J4-A	34
MR-J4-B	35
MR-JE	36
Converter MR-ENCOM	50
D	
Dimensions	63
EMC Filters	80
Extension I/O Unit	82
Functional safety unit MR-D30	82
Servo Amplifiers	69
Servo Motors	63
E	
EMC Filters	52
M	
Machine Diagnosis Function	9
Manual Pulse Generator	51
Motion Controller	58
MELSEC System Q	60
MR-MQ100	58
Q170MSCPU/Q170MSCPU-S1	59
MR-MQ100	58
P	
Positioning Units	54
MELSEC L Series	56
MELSEC System Q	55
Positioning Units	54

S

Servo Amplifiers	6
Model Designation	10
Servo Amplifier with Built-in Positioning Function	9
Servo and Motion Systems	4
Components	4
Positioning controllers	5
Servo Motor	13
Direct drive motor	14
Linear Servo Motor	15
Model Designation	12
Specifications (200 V Type)	18
HF-KN(B)	18
HF-SN(B)	19
HG-KR(B)	20
HG-MR(B)	21
HG-RR(B)	22
HG-SR(B)	23
Specifications (400 V Type)	24
HG-JR(B)	25
, 26	
HG-SR(B)	24
Specifications and Matching Amplifiers	16
Typical Applications	13
With electromagnetic brake	27
Simple Motion module	57
Software	53
G-CAD Converter	53
MR Configurator2	53
Specifications Servo Amplifier	29
MR-D30 Functional Safety Unit	33
MR-J4 (200 V Type)	30
MR-J4S (400 V Type)	31
MR-J4W2-B/MR-J4W3-B	32
MR-JE	29
SSCNETIII Module	54
Supporting Energy	9
System Configuration	62
SSCNETIII/H	61
X-Y Table System Configurations	62
T	
Terminal Blocks	51

A world of automation solutions

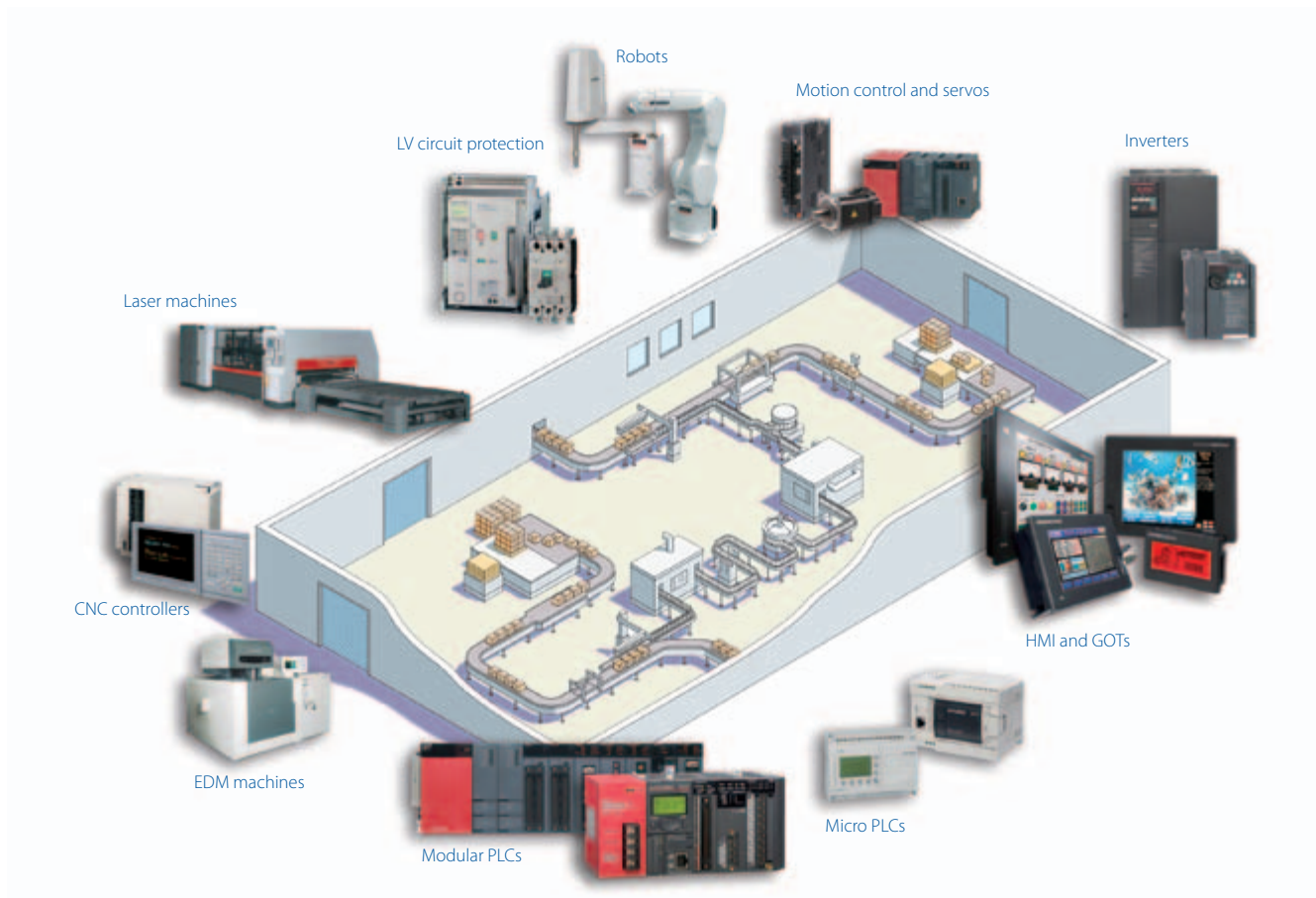

Mitsubishi Electric offers a wide range of automation equipment from PLCs and HMIs to CNC and EDM machines

A name to trust

Since its beginnings in 1870, some 45 companies use the Mitsubishi name, covering a spectrum of finance, commerce and industry.

The Mitsubishi brand name is recognized around the world as a symbol of premium quality.

Mitsubishi Electric Corporation represents space development, transportation, semiconductors, energy systems, communications and information processing, audio visual equipment, home electronics, building and energy management and automation systems, and has 237 factories and laboratories worldwide in over 121 countries.

This is why you can rely on a Mitsubishi Electric automation solution – because we know first hand about the need for reliable, efficient, easy-to-use automation and control.

As one of the world's leading companies with a global turnover of 4 trillion Yen (approximately \$40 billion), employing over 100,000 people, Mitsubishi Electric has the resource and the commitment to deliver the ultimate in service and support as well as the best products.

Global partner. Local friend.

European Offices

Mitsubishi Electric Europe B.V. Gothaer Straße 8 D-40880 Ratingen Phone: +49 (0)2102 / 486-0	Germany	Mitsubishi Electric Europe B.V. 52. bld. 1 Kosmodamianskaya emb. RU-115054 Moscow Phone: +7 495 / 721 2070	Russia
Mitsubishi Electric Europe B.V. Radlická 751/113e Avenir Business Park CZ-158 00 Praha 5 Phone: +420 251 551 470	Czech Rep.	Mitsubishi Electric Europe B.V. Carretera de Rubí 76-80 Apdo. 420 E-08190 Sant Cugat del Vallés (Barcelona) Phone: +34 (0) 93 / 5653131	Spain
Mitsubishi Electric Europe B.V. 25, Boulevard des Bouvets F-92741 Nanterre Cedex Phone: +33 (0)1 / 55 68 55 68	France	Mitsubishi Electric Europe B.V. (Scandinavia) Fjellvegögen 8 SE-22736 Lund Phone: +46 (0) 8 625 10 00	Sweden
Mitsubishi Electric Europe B.V. Viale Colleoni 7 Palazzo Sirio I-20864 Agrate Brianza (MB) Phone: +39 039 / 60 53 1	Italy	Mitsubishi Electric Turkey Elektrik Ürünleri A.Ş. Serifali Mahallesi Nutuk Sokak No:5 TR-34775 Ümraniye-İSTANBUL Phone: +90 (0)216 / 526 39 90	Turkey
Mitsubishi Electric Europe B.V. Westgate Business Park, Ballymount IRL-Dublin 24 Phone: +353 (0)1 4198800	Ireland	Mitsubishi Electric Europe B.V. Travellers Lane UK-Hatfield, Herts. AL10 8XB Phone: +44 (0)1707 / 28 87 80	UK
Mitsubishi Electric Europe B.V. Nijverheidsweg 23a NL-3641RP Mijdrecht Phone: +31 (0) 297250350	Netherlands	Mitsubishi Electric Europe B.V. Dubai Silicon Oasis United Arab Emirates - Dubai Phone: +971 4 3724716	UAE
Mitsubishi Electric Europe B.V. ul. Krakowska 50 PL-32-083 Balice Phone: +48 (0) 12 347 65 00	Poland		

Representatives

GEVA Wiener Straße 89 A-2500 Baden Phone: +43 (0)2252 / 85 55 20	Austria	Beijer Electronics A/S Lykkegårdsvej 17 DK-4000 Roskilde Phone: +45 (0)46 / 75 76 66	Denmark	Beijer Electronics SIA Ritausmas iela 23 LV-1058 Riga Phone: +371 (0)6 / 784 2280	Latvia	Sirius Trading & Services Aleea Lacul Morii Nr. 3 RO-060841 Bucuresti, Sector 6 Phone: +40 (0)21 / 430 40 06	Romania	I.C. SYSTEMS Ltd. 23 Al-Saad-Al-Alee St. EG-Sarayut, Maadi, Cairo Phone: +20 (0) 2 / 235 98 548	Egypt
OOO TECHNIKON Prospect Nezavisimosti 177-9 BY-220125 Minsk Phone: +375 (0)17 / 393 1177	Belarus	HANS FOLSGAARD A/S Theligaards Torv 1 DK-4600 Køge Phone: +45 4320 8600	Denmark	Beijer Electronics UAB Goštautu g. 3 LT-48324 Kaunas Phone: +370 37 262707	Lithuania	INEA SR d.o.o. Ul. Karadjordjeva 12/217 SER-11300 Smederevo Phone: +386 (0)26 / 461 54 01	Serbia	SHERF Motion Techn. Ltd. Rehov Harmerkava 19 IL-58851 Holon Phone: +972 (0)3 / 559 54 62	Israel
ESCO DRIVES Culliganlaan 3 BE-1831 Diegem Phone: +32 (0)2 / 717 64 60	Belgium	Beijer Electronics Eesti OÜ Pärnu mnt.160i EE-11317 Tallinn Phone: +372 (0)6 / 51 81 40	Estonia	ALFATRADE Ltd. 99, Paola Hill Malta-Paola PLA 1702 Phone: +356 (0)21 / 697 816	Malta	SIMAP SK Jána Derku 1671 SK-911 01 Trenčín Phone: +421 (0)32 743 04 72	Slovakia	CEG LIBAN Cebaco Center/Block A Autostrade DORA Lebanon-Beirut Phone: +961 (0)1 / 240 445	Lebanon
KONING & HARTMAN B.V. Woluwelaan 31 BE-1800 Wilvoorde Phone: +32 (0)2 / 257 02 40	Belgium	Beijer Electronics OY Vanha Nurmijärventie 62 FIN-01670 Vantaa Phone: +358 (0)207 / 463 500	Finland	INTEHISIS SRL bld. Traian 23/1 MD-2060 Kishinev Phone: +373 (0)22 / 66 4242	Moldova	INEA RBT d.o.o. Stegne 11 SI-1000 Ljubljana Phone: +386 (0)11 / 513 8116	Slovenia	ADROIT TECHNOLOGIES 20 Waterford Office Park 189 Witkoppen Road ZA-Fourways Phone: +27 (0)11 / 658 8100	South Africa
INEA RBT d.o.o. Stegne 11 SI-1000 Ljubljana Phone: +386 (0)11 / 513 8116	Bosnia and Herzegovina	PROVENDOR OY Teljänkatu 8 A3 FIN-28130 Pori Phone: +358 (0)2 / 522 3300	Finland	HIFLEX AUTOM. B.V. Wolwevestaat 22 NL-2984 CD Ridderkerk Phone: +31 (0)180 / 46 60 04	Netherlands	Beijer Electronics Automation AB Box 426 SE-20124 Malmö Phone: +46 (0)40 / 35 86 00	Sweden		
AKHNATON 4, Andrei Lipachev Blvd., PO Box 21 BG-1756 Sofia Phone: +359 (0)2 / 817 6000	Bulgaria	UTECO A.B.E.E. 5, Mavrogenous Str. GR-18542 Piraeus Phone: +359 (0)11 / 1206-900	Greece	KONING & HARTMAN B.V. NL-2627 AP Delft Phone: +31 (0)15 260 99 06	Netherlands	OMNI RAY AG Im Schörlö 5 CH-8600 Dübendorf Phone: +41 (0)44 / 802 28 80	Switzerland		
INEA CR Losańska 4 a HR-10000 Zagreb Phone: +385 (0)1 / 36 940 - 017 - 02 / -03	Croatia	MELTRADE Kft. Fertő utca 14, HU-1107 Budapest Phone: +36 (0)1 / 431-9726	Hungary	Beijer Electronics AS Postboks 487 NO-3002 Drammen Phone: +47 (0)32 / 24 30 00	Norway	OOO "CSC-AUTOMATION" 4-B, M. Raskolnyy St. UA-02660 Kiev Phone: +380 (0)44 / 494 33 44	Ukraine		
AutoCont C.S. S.R.O. Kafkova 1853/3 CZ-702 00 Ostrava 2 Phone: +420 595 691 150	Czech Republic	TOO Kazpromavtomatika Ul. Zhambyla 28 KAZ-100017 Karaganda Phone: +7 7212 / 50 10 00	Kazakhstan	Fonseca S.A. R. João Francisco do Casal 87/89 PF-3801-997 Aveiro, Esqueira Phone: +351 (0)234 / 303 900	Portugal				



Version check

Mitsubishi Electric Europe B.V. / FA - European Business Group / Gothaer Straße 8 / D-40880 Ratingen / Germany / Tel.: +49(0)2102-4860 / Fax: +49(0)2102-4861120 / info@mitsubishi-automation.com / https://eu3a.mitsubishielectric.com

Art. no. 209265-E / 09.2014 / Specifications subject to change / All trademarks and copyrights acknowledged.

